

CC3235MODx and CC3235MODAx SimpleLink™ Wi-Fi CERTIFIED™ Dual-Band Wireless MCU Modules

1 Features

- Fully integrated and green and RoHS modules include all required clocks, SPI flash, and passives
- 802.11a/b/g/n: 2.4GHz and 5GHz
- FCC, IC/ISED, ETSI/CE, MIC, and SRRC ¹certified
- FIPS 140-2 Level 1 validated IC inside
- Multilayered security features help developers protect identities, data, and software IP
- Low-power modes for battery-powered applications
- Coexistence with 2.4GHz radios
- Industrial temperature: –40°C to +85°C
- CC3235MODx multiple-core architecture, system-on-chip (SoC)
- CC3235MODAx modules include an integrated PCB antenna for easy integration into the host system
- 1.27mm pitch QFM package for easy assembly and low-cost PCB design
- Transferable Wi-Fi Alliance® certification
- Application microcontroller subsystem:
 - Arm® Cortex®-M4 core at 80MHz
 - User-dedicated memory
 - 256KB of RAM
 - Optional 1MB of executable flash
 - Rich set of peripherals and timers
 - McASP supports two I2S channels
 - SD, SPI, I²C, UART
 - 8-bit synchronous imager interface
 - 4-channel 12-bit ADCs
 - 4 general-purpose timers (GPT) with 16-bit PWM mode
 - Watchdog timer
 - Up to 27 GPIO pins
 - Debug interfaces: JTAG, cJTAG, SWD
- **Wi-Fi network processor subsystem:**
 - Wi-Fi® core:
 - 802.11 a/b/g/n 2.4GHz and 5GHz
 - Modes:
 - Access point (AP)
 - Station (STA)
 - Wi-Fi Direct® (only supported on 2.4GHz)
- Security:
 - WEP
 - WPA™/ WPA2™ PSK
 - WPA2 Enterprise
 - WPA3™ Personal
 - WPA3™ Enterprise
- Internet and application protocols:
 - HTTPs server, mDNS, DNS-SD, DHCP
 - IPv4 and IPv6 TCP/IP stack
 - 16 BSD sockets (fully secured TLS v1.2 and SSL 3.0)
- Built-in power management subsystem:
 - Configurable low-power profiles (always on, intermittently connected, tag)
 - Advanced low-power modes
 - Integrated DC/DC regulators
- **Multilayered security features:**
 - Separate execution environments
 - Networking security
 - Device identity and key
 - Hardware accelerator cryptographic engines (AES, DES, SHA/MD5, CRC)
 - File system security (encryption, authentication, access control)
 - Initial secure programming
 - Software tamper detection
 - Secure boot
 - Certificate signing request (CSR)
 - Unique per device key pair
- Application throughput
 - UDP: 16Mbps
 - TCP: 13Mbps
- **Power-Management Subsystem:**
 - Integrated DC/DC converters support a wide range of supply voltage:
 - Single wide-voltage supply, VBAT: 2.3V to 3.6V
 - Advanced low-power modes:
 - Shutdown: 1µA, Hibernate: 5.5µA
 - Low-power deep sleep (LPDS): 120µA
 - Idle connected (MCU in LPDS): 710µA
 - RX traffic (MCU active): 59mA
 - TX traffic (MCU active): 223mA

¹ Contact TI for more information on using SRRC ID Certification: www.ti.com/tool/SIMPLELINK-CC3XXX-CERTIFICATION



- Wi-Fi TX power
 - 2.4GHz: 16dBm at 1 DSSS
 - 5GHz: 15.1dBm at 6 OFDM
- Wi-Fi RX sensitivity
 - 2.4GHz: –94.5dBm at 1 DSSS
 - 5GHz: –89dBm at 6 OFDM
- Additional integrated components
 - 40.0MHz crystal
 - 32.768kHz crystal (RTC)
 - 32Mbit SPI serial flash
 - RF filters, diplexer and passive components
- Footprint-compatible QFM package
 - CC3235MODx: 1.27mm pitch, 63-pin, 20.5mm × 17.5mm
 - CC3235MODAx: 1.27mm pitch, 63-pin, 20.5mm × 25.0mm
- Module supports the [SimpleLink Developer's Ecosystem](#)

3 Description

Start your design with the fully programmable FCC, IC/ISED, ETSI/CE, MIC, and SRRC certified wireless microcontroller (MCU) module with built-in dual-band Wi-Fi connectivity. The modules integrate the 40MHz crystal, 32.768kHz RTC clock, 32Mb SPI serial flash, RF filters, diplexer, and passive components.

The SimpleLink™ CC3235MODx module is available in two variants:

- [CC3235MODS](#) includes 256KB of RAM, IoT networking security, device identity and keys, and MCU-level security features such as file system encryption, user IP (MCU image) encryption, secure boot, and debug security.
- [CC3235MODSF](#) builds on the CC3235MODS and integrates a user-dedicated 1MB of executable flash in addition to the 256KB of RAM.

The SimpleLink™ CC3235MODAx module is available in two variants:

- [CC3235MODAS](#) includes 256KB of RAM, IoT networking security, device identity and keys, and MCU-level security features such as file system encryption, user IP (MCU image) encryption, secure boot, and debug security.
- [CC3235MODASF](#) builds on the CC3235MODAS and integrates a user-dedicated 1MB of executable flash in addition to the 256KB of RAM.

Created for IoT, the [SimpleLink™ Wi-Fi®](#) CC3235MODx and CC3235MODAx module family from Texas Instruments is a wireless module that integrates two physically separated on-chip MCUs.

- Application processor—Arm® Cortex®-M4 MCU with a user-dedicated 256KB of RAM and an optional 1MB of executable flash.
- Network processor to run all Wi-Fi and Internet logical layers. This ROM-based subsystem completely offloads the host MCU and includes an 802.11 a/b/g/n dual-band 2.4GHz and 5GHz radio, baseband, and MAC with a powerful hardware cryptography engine.

This generation introduces new capabilities that further simplify the connectivity of things to the Internet. The main new features include:

- 802.11a/b/g/n: 2.4GHz and 5GHz support
- 2.4GHz coexistence with [Bluetooth®](#) low energy radio
- Antenna diversity
- Enhanced security with FIPS 140-2 Level 1 validated IC inside: [certification](#).
- More concurrent secure sockets (up to 16)
- Certificate signing request (CSR)
- Online certificate status protocol (OCSP)

2 Applications

- For Internet of Things applications, such as:
 - [Medical and healthcare](#)
 - [Multiparameter patient monitor](#)
 - [Electrocardiogram \(ECG\)](#)
 - [Electronic hospital bed and bed control](#)
 - [Telehealth systems](#)
 - [Building and home automation](#):
 - [HVAC systems and thermostats](#)
 - [Video surveillance, video doorbells, and low-power camera](#)
 - [Building security systems and e-locks](#)
 - [Appliances](#)
 - [Asset tracking](#)
 - [Factory automation](#)
 - [Grid infrastructure](#)

- Wi-Fi Alliance® certified for IoT applications with low-power capabilities and more
- Hostless mode for offloading template packet transmissions
- Improved fast scan

The CC3235MODx and CC3235MODAx device family is part of the SimpleLink MCU platform—a common, easy-to-use development environment based on a single-core software development kit (SDK) with a rich tool set and reference designs. The E2E™ support forums support Wi-Fi, Bluetooth low energy, Sub1GHz, and host MCUs. For more information, visit www.ti.com/simplelink or www.ti.com/simplelinkwifi.

Device Information ⁽¹⁾

PART NUMBER	PACKAGE	PACKAGE SIZE
CC3235MODSM2MOB	QFM (63)	20.5mm × 17.5mm
CC3235MODSF12MOB	QFM (63)	20.5mm × 17.5mm
CC3235MODASM2MON	QFM (63)	20.5mm × 25mm
CC3235MODASF12MON	QFM (63)	20.5mm × 25mm

(1) For more information, see [Section 13](#).

4 Functional Block Diagrams

Figure 4-1 shows the functional block diagram of the CC3235MODx module.

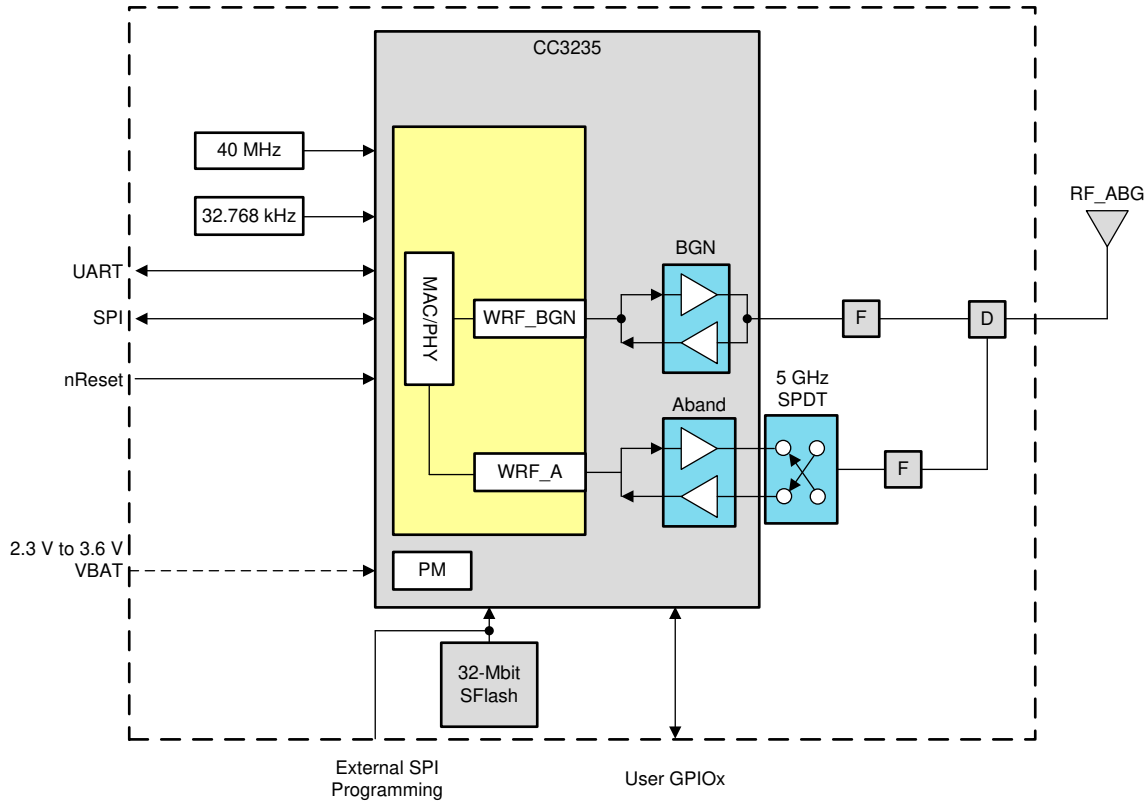

Figure 4-1. CC3235MODx Functional Block Diagram

Figure 4-2 shows the functional block diagram of the CC3235MODAx module.

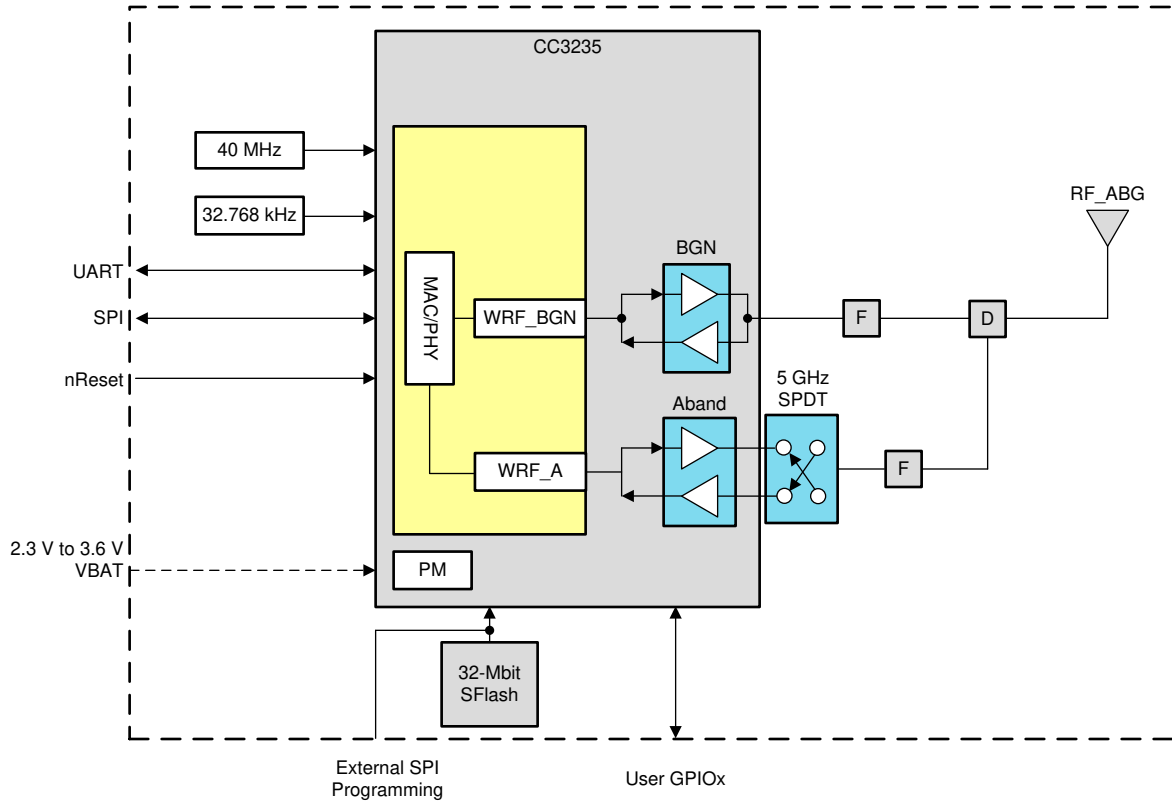

Figure 4-2. CC3235MODAx Functional Block Diagram

Figure 4-3 shows the an overview of the CC3235x hardware.

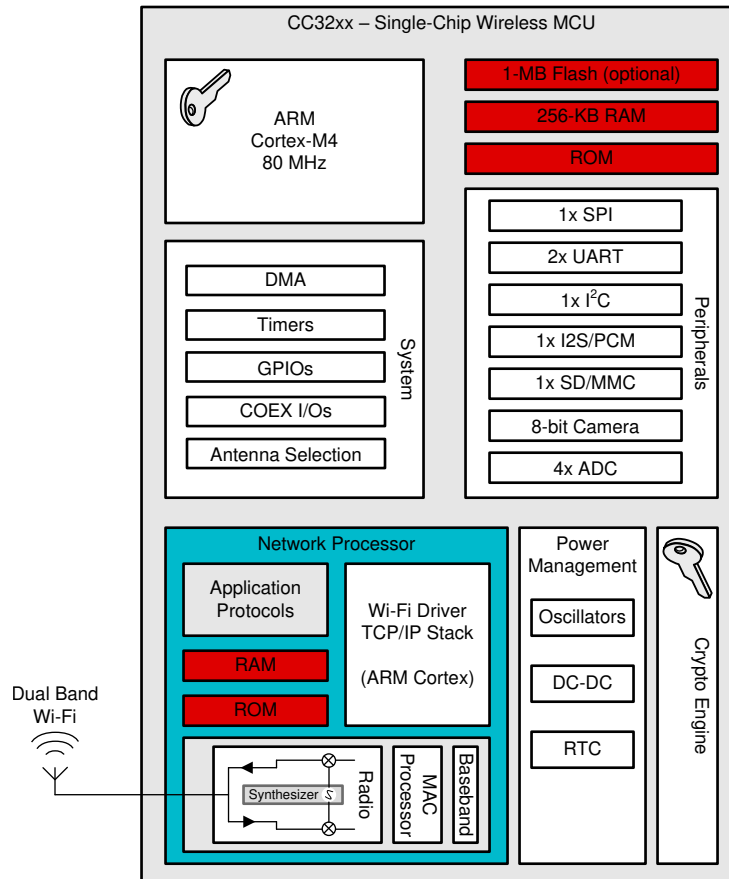

Figure 4-3. CC3235x Hardware Overview

Figure 4-4 shows the an overview of the CC3235x embedded software.

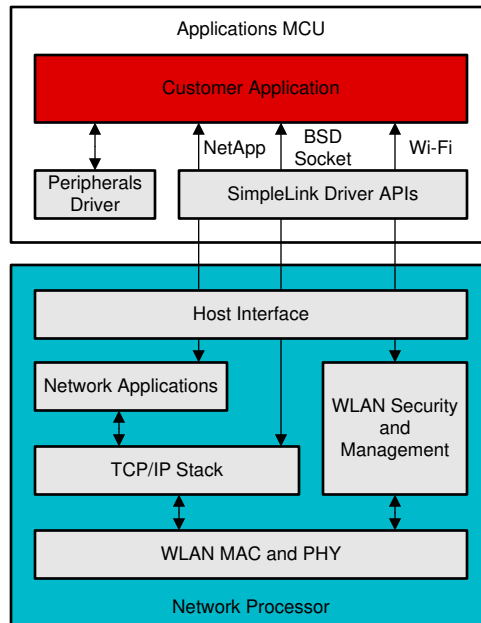

Figure 4-4. CC3235x Embedded Software Overview

Table of Contents

1 Features	1	8.5 Security.....	68
2 Applications	2	8.6 FIPS 140-2 Level 1 Certification.....	70
3 Description	2	8.7 Power-Management Subsystem.....	70
4 Functional Block Diagrams	4	8.8 Low-Power Operating Mode.....	70
5 Device Comparison	9	8.9 Memory.....	72
5.1 Related Products.....	12	8.10 Restoring Factory Default Configuration.....	74
6 Pin Configuration and Functions	13	8.11 Boot Modes.....	74
6.1 CC3235MODx and CC3235MODAx Pin Diagram.....	13	8.12 Hostless Mode.....	75
6.2 Pin Attributes and Pin Multiplexing.....	14	8.13 Device Certification and Qualification.....	76
6.3 Signal Descriptions.....	32	8.14 Module Markings.....	78
6.4 Drive Strength and Reset States for Analog-Digital Multiplexed Pins.....	37	8.15 End Product Labeling.....	79
6.5 Pad State After Application of Power to Chip, but Before Reset Release.....	37	8.16 Manual Information to the End User.....	79
6.6 Connections for Unused Pins.....	37	9 Applications, Implementation, and Layout	80
7 Specifications	38	9.1 Typical Application.....	80
7.1 Absolute Maximum Ratings.....	38	9.2 Device Connection and Layout Fundamentals.....	87
7.2 ESD Ratings.....	38	9.3 PCB Layout Guidelines.....	87
7.3 Recommended Operating Conditions.....	38	10 Environmental Requirements and SMT Specifications	94
7.4 Current Consumption (CC3235MODS and CC3235MODAS).....	39	10.1 PCB Bending.....	94
7.5 Current Consumption (CC3235MODSF and CC3235MODASF).....	41	10.2 Handling Environment.....	94
7.6 TX Power Control for 2.4 GHz Band.....	43	10.3 Storage Condition.....	94
7.7 TX Power Control for 5 GHz.....	45	10.4 PCB Assembly Guide.....	94
7.8 Brownout and Blackout Conditions.....	45	10.5 Baking Conditions.....	95
7.9 Electrical Characteristics for GPIO Pins.....	47	10.6 Soldering and Reflow Condition.....	96
7.10 CC3235MODAx Antenna Characteristics.....	49	11 Device and Documentation Support	97
7.11 WLAN Receiver Characteristics.....	49	11.1 Development Tools and Software.....	97
7.12 WLAN Transmitter Characteristics.....	50	11.2 Firmware Updates.....	98
7.13 BLE and WLAN Coexistence Requirements.....	51	11.3 Device Nomenclature.....	98
7.14 Reset Requirement.....	51	11.4 Documentation Support.....	99
7.15 Thermal Resistance Characteristics for MOB and MON Packages.....	51	11.5 Related Links.....	100
7.16 Timing and Switching Characteristics.....	52	11.6 Support Resources.....	101
8 Detailed Description	64	11.7 Trademarks.....	101
8.1 Overview.....	64	11.8 Electrostatic Discharge Caution.....	101
8.2 Functional Block Diagram.....	64	11.9 Glossary.....	101
8.3 Arm Cortex-M4 Processor Core Subsystem.....	65	12 Revision History	101
8.4 Wi-Fi Network Processor Subsystem.....	66	13 Mechanical, Packaging, and Orderable Information	102
		13.1 Mechanical, Land, and Solder Paste Drawings....	102
		13.2 Package Option Addendum.....	102

5 Device Comparison

Table 5-2 shows the features supported across different CC3x35 modules.

Table 5-1. Device Features Comparison

FEATURE	DEVICE		
	CC3135MOD	CC3235MODS	CC3235MODSF
On-board chip	CC3135	CC3235S	CC3235SF
On-board ANT	No	No	No
sFlash	32-Mbit	32-Mbit	32-Mbit
Regulatory certifications	FCC, IC/ISED, ETSI/CE, MIC	FCC, IC/ISED, ETSI/CE, MIC	FCC, IC/ISED, ETSI/CE, MIC
Wi-Fi Alliance® Certification	Yes	Yes	Yes
Input voltage	2.3 V to 3.6 V	2.3 V to 3.6 V	2.3 V to 3.6 V
Package	17.5 mm × 20.5 mm QFM	17.5 mm × 20.5 mm QFM	17.5 mm × 20.5 mm QFM
Operating temperature range	–40°C to +85°C	–40°C to +85°C	–40°C to +85°C
Classification	Wi-Fi Network Processor	Wireless Microcontroller	Wireless Microcontroller
Standard	802.11 a/b/g/n	802.11 a/b/g/n	802.11 a/b/g/n
Frequency	2.4GHz, 5 GHz	2.4GHz, 5 GHz	2.4GHz, 5 GHz
TCP/IP Stack	IPv4, IPv6	IPv4, IPv6	IPv4, IPv6
Secured sockets	16	16	16
Integrated MCU	–	Arm Cortex-M4 at 80 MHz	Arm Cortex-M4 at 80 MHz
ON-CHIP APPLICATION MEMORY			
RAM	–	256KB	256KB
Flash	–	–	1MB
PERIPHERALS AND INTERFACES			
Universal Asynchronous Receiver/Transmitter (UART)	1	2	2
Serial Port Interface (SPI)	1	1	1
Multichannel Audio Serial Port (McASP)- I2S or PCM	–	2-ch	2-ch
Inter-Integrated Circuit (I ² C)	–	1	1
Analog-to-digital converter (ADC)	–	4-ch, 12-bit	4-ch, 12-bit
Parallel interface (8-bit PI)	–	1	1
General-purpose timers	–	4	4
Multimedia card (MMC / SD)	–	1	1
SECURITY FEATURES			

Table 5-1. Device Features Comparison (continued)

FEATURE	DEVICE		
	CC3135MOD	CC3235MODS	CC3235MODSF
Additional networking security	Unique Device Identity Trusted Root-Certificate Catalog TI Root-of-Trust Public key	Unique Device Identity Trusted Root-Certificate Catalog TI Root-of-Trust Public key	Unique Device Identity Trusted Root-Certificate Catalog TI Root-of-Trust Public key
Hardware acceleration	Hardware Crypto Engines	Hardware Crypto Engines	Hardware Crypto Engines
Secure boot	–	Yes	Yes
Enhanced Application Level Security	–	File system security Secure key storage Software tamper detection Cloning protection Initial secure programming	File system security Secure key storage Software tamper detection Cloning protection Initial secure programming
FIPS 140-2 Level 1 Certification	Yes	Yes	Yes

Table 5-2. Device Features Comparison

FEATURE	DEVICE				
	CC3135MOD	CC3235MODS	CC3235MODSF	CC3235MODAS	CC3235MODASF
On-board chip	CC3135	CC3235S	CC3235SF	CC3235S	CC3235SF
On-board ANT	No	No	No	Yes	Yes
sFlash	32-Mbit	32-Mbit	32-Mbit	32-Mbit	32-Mbit
Regulatory certifications	FCC, IC/ISED, ETSI/CE, MIC	FCC, IC/ISED, ETSI/CE, MIC	FCC, IC/ISED, ETSI/CE, MIC	FCC, IC/ISED, ETSI/CE, MIC, SRRC ⁽¹⁾	FCC, IC/ISED, ETSI/CE, MIC, SRRC ⁽¹⁾
Wi-Fi Alliance® Certification	Yes	Yes	Yes	Yes	Yes
Input voltage	2.3 V to 3.6 V	2.3 V to 3.6 V	2.3 V to 3.6 V	2.3 V to 3.6 V	2.3 V to 3.6 V
Package	17.5 mm × 20.5 mm QFM	17.5 mm × 20.5 mm QFM	17.5 mm × 20.5 mm QFM	25.0 mm × 20.5 mm QFM	25.0 mm × 20.5 mm QFM
Operating temperature range	–40°C to +85°C	–40°C to +85°C	–40°C to +85°C	–40°C to +85°C	–40°C to +85°C
Classification	Wi-Fi Network Processor	Wireless Microcontroller	Wireless Microcontroller	Wireless Microcontroller	Wireless Microcontroller
Standard	802.11 a/b/g/n	802.11 a/b/g/n	802.11 a/b/g/n	802.11 a/b/g/n	802.11 a/b/g/n
Frequency	2.4GHz, 5 GHz	2.4GHz, 5 GHz	2.4GHz, 5 GHz	2.4GHz, 5 GHz	2.4GHz, 5 GHz
TCP/IP Stack	IPv4, IPv6	IPv4, IPv6	IPv4, IPv6	IPv4, IPv6	IPv4, IPv6
Secured Sockets	16	16	16	16	16
Integrated MCU	–	Arm Cortex-M4 at 80 MHz	Arm Cortex-M4 at 80 MHz	Arm Cortex-M4 at 80 MHz	Arm Cortex-M4 at 80 MHz
ON-CHIP APPLICATION MEMORY					
RAM	–	256KB	256KB	256KB	256KB
Flash	–	–	1MB	–	1MB
PERIPHERALS AND INTERFACES					
Universal Asynchronous Receiver/Transmitter (UART)	1	2	2	2	2
Serial Port Interface (SPI)	1	1	1	1	1

Table 5-2. Device Features Comparison (continued)

FEATURE	DEVICE				
	CC3135MOD	CC3235MODS	CC3235MODSF	CC3235MODAS	CC3235MODASF
Multichannel Audio Serial Port (McASP)- I2S or PCM	–	2-ch	2-ch	2-ch	2-ch
Inter-Integrated Circuit (I ² C)	–	1	1	1	1
Analog-to-digital converter (ADC)	–	4-ch, 12-bit	4-ch, 12-bit	4-ch, 12-bit	4-ch, 12-bit
Parallel interface (8-bit PI)	–	1	1	1	1
General-purpose timers	–	4	4	4	4
Multimedia card (MMC / SD)	–	1	1	1	1
SECURITY FEATURES					
Additional networking security	Unique Device Identity Trusted Root-Certificate Catalog TI Root-of-Trust Public key	Unique Device Identity Trusted Root-Certificate Catalog TI Root-of-Trust Public key	Unique Device Identity Trusted Root-Certificate Catalog TI Root-of-Trust Public key	Unique Device Identity Trusted Root-Certificate Catalog TI Root-of-Trust Public key	Unique Device Identity Trusted Root-Certificate Catalog TI Root-of-Trust Public key
Hardware acceleration	Hardware Crypto Engines	Hardware Crypto Engines	Hardware Crypto Engines	Hardware Crypto Engines	Hardware Crypto Engines
Secure boot	–	Yes	Yes	Yes	Yes
Enhanced Application Level Security	–	File system security Secure key storage Software tamper detection Cloning protection Initial secure programming	File system security Secure key storage Software tamper detection Cloning protection Initial secure programming	File system security Secure key storage Software tamper detection Cloning protection Initial secure programming	File system security Secure key storage Software tamper detection Cloning protection Initial secure programming
FIPS 140-2 Level 1 Certification	Yes	Yes	Yes	Yes	Yes

(1) Contact TI for more information on using SRRC ID Certification: www.ti.com/tool/SIMPLELINK-CC3XXX-CERTIFICATION

5.1 Related Products

For information about other devices in this family of products or related products see the links below.

[The SimpleLink™ MCU Portfolio](#)

Offers a single development environment that delivers flexible hardware, software and tool options for customers developing wired and wireless applications. With 100 percent code reuse across host MCUs, Wi-Fi®, Bluetooth® low energy, Sub1GHz devices and more, choose the MCU or connectivity standard that fits your design. A one-time investment with the SimpleLink software development kit (SDK) allows you to reuse often, opening the door to create unlimited applications.

[SimpleLink™ Wi-Fi® Family](#)

The SimpleLink Wi-Fi Family offers several Internet-on-a chip solutions, which address the need of battery operated, security enabled products. Texas instruments offers a single chip wireless microcontroller and a wireless network processor which can be paired with any MCU, to allow developers to design new wi-fi products, or upgrade existing products with wi-fi capabilities.

[BoosterPack™ Plug-In Modules](#)

BoosterPack™ Plug-In Modules extend the functionality of TI LaunchPad Kit. Application specific BoosterPack Plug in modules allow you to explore a broad range of applications, including capacitive touch, wireless sensing, LED Lighting control, and more. Stack multiple BoosterPack modules onto a single LaunchPad kit to further enhance the functionality of your design.

[Reference Designs for CC3200, CC3220, and CC3235 Modules](#)

TI Designs Reference Design Library is a robust reference design library spanning analog, embedded processor and connectivity. Created by TI experts to help you jump start your system design, all TI Designs include schematic or block diagrams, BOMs and design files to speed your time to market.

[SimpleLink™ Wi-Fi® CC3235 SDK](#)

The SDK contains drivers for the CC3235 programmable MCU, sample applications, and documentation required to start development with CC3235x solutions.

6 Pin Configuration and Functions

6.1 CC3235MODx and CC3235MODAx Pin Diagram

Figure 6-1 shows the pin diagram for the CC3235MODx module.

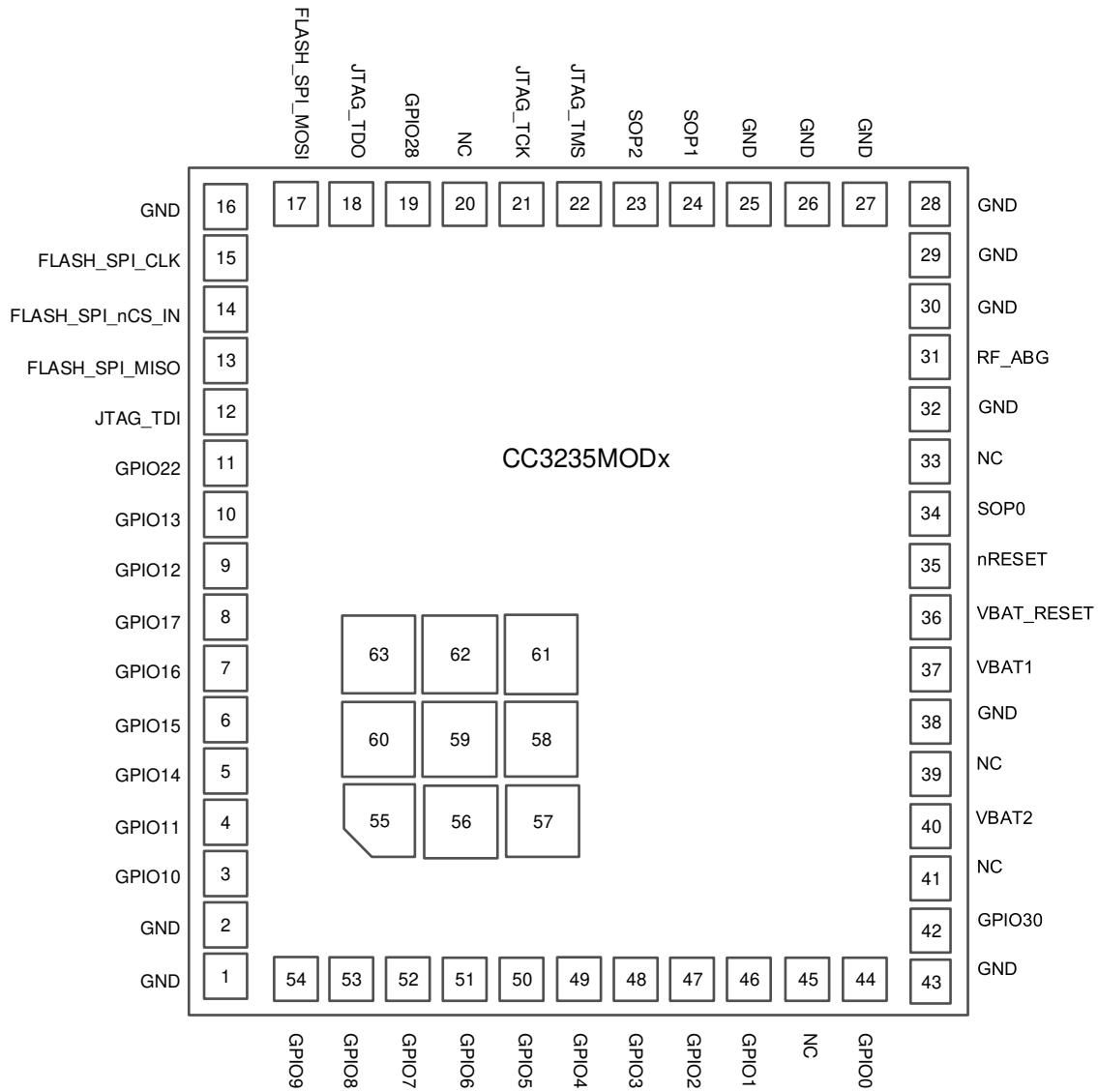

Figure 6-1 shows the approximate location of pins on the module.

Figure 6-1. CC3235MODx Pin Diagram Bottom View

Figure 6-2 shows the pin diagram for the CC3235MODAx module.

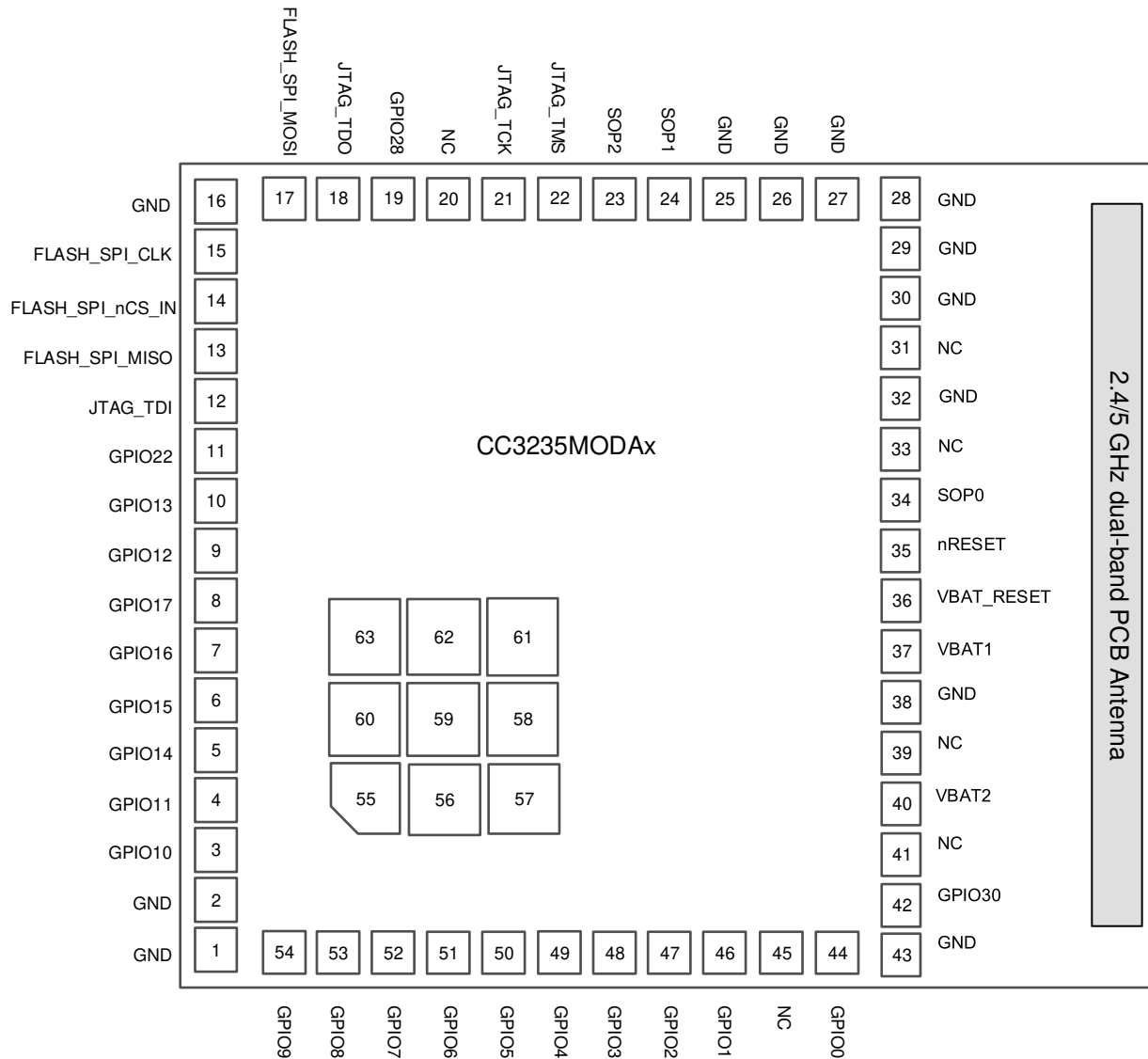

Figure 6-2. CC3235MODAx Pin Diagram Bottom View

6.2 Pin Attributes and Pin Multiplexing

Section 6.2.1 lists the pin descriptions of the CC3235MODx and CC3235MODAx module.

6.2.1 Module Pin Descriptions

MODULE PIN		TYPE ⁽¹⁾	CC3235 DEVICE PIN NO.	MODULE PIN DESCRIPTION
NO.	NAME			
1	GND	–	–	Ground
2	GND	–	–	Ground
3	GPIO10	I/O	1	GPIO ⁽²⁾
4	GPIO11	I/O	2	GPIO ⁽²⁾
5	GPIO14	I/O	5	GPIO ⁽²⁾
6	GPIO15	I/O	6	GPIO ⁽²⁾
7	GPIO16	I/O	7	GPIO ⁽²⁾
8	GPIO17	I/O	8	GPIO ⁽²⁾
9	GPIO12	I/O	3	GPIO ⁽²⁾
10	GPIO13	I/O	4	GPIO ⁽²⁾
11	GPIO22	I/O	15	GPIO ⁽²⁾
12	JTAG_TDI	I/O	16	JTAG TDI input. Leave unconnected if not used on product ⁽²⁾
13	FLASH_SPI_MISO	I	–	External serial flash programming: SPI data in
14	FLASH_SPI_nCS_IN	I	–	External serial flash programming: SPI chip select (active low)
15	FLASH_SPI_CLK	I	–	External serial flash programming: SPI clock
16	GND	–	–	Ground
17	FLASH_SPI_MOSI	O	–	External serial flash programming: SPI data out
18	JTAG_TDO	I/O	17	JTAG TDO output. Leave unconnected if not used on the product. ⁽¹⁾
19	GPIO28	I/O	18	GPIO ⁽²⁾
20	NC	–	–	No Connect
21	JTAG_TCK	I/O	19	JTAG TCK input. Leave unconnected if not used on the product. ⁽²⁾ An internal 100kΩ pulldown resistor is tied to this pin.
22	JTAG_TMS	I/O	20	JTAG TMS input. Leave unconnected if not used on the product. ⁽²⁾
23	SOP2	–	21	An internal 100kΩ pulldown resistor is tied to this SOP pin. An external 10kΩ resistor is required to pull this pin high. See Section 8.11.1 for SOP[2:0] configuration modes.
24	SOP1	–	34	An internal 100kΩ pulldown resistor is tied to this SOP pin. An external 10kΩ resistor is required to pull this pin high. See Section 8.11.1 for SOP[2:0] configuration modes.
25	GND	–	–	Ground
26	GND	–	–	Ground
27	GND	–	–	Ground
28	GND	–	–	Ground
29	GND	–	–	Ground

MODULE PIN		TYPE ⁽¹⁾	CC3235 DEVICE PIN NO.	MODULE PIN DESCRIPTION
NO.	NAME			
30	GND	–	–	Ground
31	CC3235MODx: RF ABG band CC3235MODAx: NC	I/O	31	2.4GHz and 5 GHz RF input/output
32	GND	–	–	Ground
33	NC	–	–	No Connect
34	SOP0	–	35	An internal 100kΩ pulldown resistor is tied to this SOP pin. An external 10kΩ resistor is required to pull this pin high. See Section 8.11.1 for SOP[2:0] configuration modes.
35	nRESET	I	32	<p>There is an internal, 100kΩ pullup resistor option from the nRESET pin to VBAT_RESET. Note: VBAT_RESET is not connected to VBAT1 or VBAT2 within the module. The following connection schemes are recommended:</p> <ul style="list-style-type: none"> Connect nRESET to a switch, external controller, or host, only if nRESET will be in a defined state under all operating conditions. Leave VBAT_RESET unconnected to save power. If nRESET cannot be in a defined state under all operating conditions, connect VBAT_RESET to the main module power supply (VBAT1 and VBAT2). Due to the internal pullup resistor a leakage current of 3.3V / 100kΩ is expected.
36	VBAT_RESET	–	37	
37	VBAT1	Power	39	Power supply for the module, must be connected to battery (2.3V to 3.6V)
38	GND	–	–	Ground
39	NC	–	47	No Connect
40	VBAT2	Power	10, 44, 54	Power supply for the module, must be connected to battery (2.3V to 3.6V)
41	NC	–	–	No Connect
42	GPIO30	I/O	53	GPIO ⁽²⁾
43	GND	–	–	Ground
44	GPIO0	I/O	50	GPIO ⁽²⁾
45	NC	–	–	No Connect
46	GPIO1	I/O	55	GPIO ⁽²⁾
47	GPIO2	I/O	57	GPIO ⁽²⁾
48	GPIO3	I/O	58	GPIO ⁽²⁾
49	GPIO4	I/O	59	GPIO ⁽²⁾
50	GPIO5	I/O	60	GPIO ⁽²⁾
51	GPIO6	I/O	61	GPIO ⁽²⁾
52	GPIO7	I/O	62	GPIO ⁽²⁾
53	GPIO8	I/O	63	GPIO ⁽²⁾
54	GPIO9	I/O	64	GPIO ⁽²⁾

MODULE PIN		TYPE ⁽¹⁾	CC3235 DEVICE PIN NO.	MODULE PIN DESCRIPTION
NO.	NAME			
55	GND	–	–	Thermal ground
56	GND	–	–	Thermal ground
57	GND	–	–	Thermal ground
58	GND	–	–	Thermal ground
59	GND	–	–	Thermal ground
60	GND	–	–	Thermal ground
61	GND	–	–	Thermal ground
62	GND	–	–	Thermal ground
63	GND	–	–	Thermal ground

(1) I = input; O = output; I/O = bidirectional

(2) For pin multiplexing details, see [Table 6-1](#).

The module makes extensive use of pin multiplexing to accommodate the large number of peripheral functions in the smallest possible package. To achieve this configuration, pin multiplexing is controlled using a combination of hardware configuration (at module reset) and register control.

The board and software designers are responsible for the proper pin multiplexing configuration. Hardware does not ensure that the proper pin multiplexing options are selected for the peripherals or interface mode used. [Table 6-1](#) describes the general pin attributes and presents an overview of pin multiplexing. All pin multiplexing options are configurable using the pin MUX registers. The following special considerations apply:

- All I/Os support drive strengths of 2mA, 4mA, and 6mA. Drive strength is individually configurable for each pin.
- All I/Os support 10µA pullup and pulldown resistors.
- By default, all I/Os float in the Hibernate state. However, the default state can be changed by SW.
- All digital I/Os are non-failsafe.

Note

If an external device drives a positive voltage to the signal pads and the CC3235MODx or CC3235MODAx module is not powered, DC is drawn from the other device. If the drive strength of the external device is adequate, an unintentional wakeup and boot of the CC3235MODx or CC3235MODAx module can occur. To prevent current draw, TI recommends any one of the following conditions:

- All devices interfaced to the CC3235MODx and CC3235MODAx modules must be powered from the same power rail as the chip.
- Use level shifters between the device and any external devices fed from other independent rails.
- The nRESET pin of the CC3235MODx and CC3235MODAx modules must be held low until the VBAT supply to the module is driven and stable.
- All GPIO pins default to high impedance unless programmed by the MCU. The bootloader sets the TDI, TDO, TCK, TMS, and Flash_SPI pins to mode 1. All the other pins are left in the Hi-Z state.

The ADC inputs are tolerant up to 1.8 V (see [Table 7-24](#) for more details about the usable range of the ADC). On the other hand, the digital pads can tolerate up to 3.6 V. Hence, take care to prevent accidental damage to the ADC inputs. TI recommends first disabling the output buffers of the digital I/Os corresponding to the desired ADC channel (that is, converted to Hi-Z state), and thereafter disabling the respective pass switches (S7 [Pin 47], S8 [Pin 48], S9 [Pin 49], and S10 [Pin 50]). For more information, see [Table 6-3](#).

Table 6-1. Pin Attributes and Pin Multiplexing

GENERAL PIN ATTRIBUTES						FUNCTION					PAD STATES		
Pkg. Pin	Pin Alias	Use	Select as Wakeup Source	Config. Addl. Analog Mux	Muxed With JTAG	Dig. Pin Mux Config. Reg.	Dig. Pin Mux Config. Mode Value	Signal Name	Signal Description	Signal Direction	LPDS ⁽¹⁾	Hib ⁽²⁾	nRESET = 0
1	GND	GND	N/A	N/A	N/A	N/A	N/A	GND	GND	N/A	N/A	N/A	N/A
2	GND	GND	N/A	N/A	N/A	N/A	N/A	GND	GND	N/A	N/A	N/A	N/A
3	GPIO10	I/O	No	No	No	GPIO_PAD_CONFIG_10 (0x4402 E0C8)	0	GPIO10	GPIO	I/O	Hi-Z, Pull, Drive	Hi-Z, Pull, Drive	Hi-Z
							1	I2C_SCL	I ² C clock	I/O (open drain)	Hi-Z, Pull, Drive		
							3	GT_PWM06	Pulse-width modulated O/P	O	Hi-Z, Pull, Drive		
							7	UART1_TX	UART TX data	O	1		
							6	SDCARD_CLK	SD card clock	O	0		
							12	GT_CCP01	Timer capture port	I	Hi-Z, Pull, Drive		

Table 6-1. Pin Attributes and Pin Multiplexing (continued)

GENERAL PIN ATTRIBUTES						FUNCTION					PAD STATES		
Pkg. Pin	Pin Alias	Use	Select as Wakeup Source	Config. Addl. Analog Mux	Muxed With JTAG	Dig. Pin Mux Config. Reg.	Dig. Pin Mux Config. Mode Value	Signal Name	Signal Description	Signal Direction	LPDS ⁽¹⁾	Hib ⁽²⁾	nRESET = 0
4	GPIO11	I/O	Yes	No	No	GPIO_PAD_CONFIG_11 (0x4402 E0CC)	0	GPIO11	GPIO	I/O	Hi-Z, Pull, Drive	Hi-Z, Pull, Drive	Hi-Z
							1	I2C_SDA	I ² C data	I/O (open drain)	Hi-Z, Pull, Drive		
							3	GT_PWM07	Pulse-width modulated O/P	O	Hi-Z, Pull, Drive		
							4	pXCLK (XVCLK)	Free clock to parallel camera	O	0		
							6	SDCARD_CMD	SD card command line	I/O (open drain)	Hi-Z, Pull, Drive		
							7	UART1_RX	UART RX data	I	Hi-Z, Pull, Drive		
							12	GT_CCP02	Timer capture port	I	Hi-Z, Pull, Drive		
							13	MCAFSX	I2S audio port frame sync	O	Hi-Z, Pull, Drive		
5	GPIO14	I/O	No	No	No	GPIO_PAD_CONFIG_14 (0x4402 E0D8)	0	GPIO14	GPIO	I/O	Hi-Z, Pull, Drive	Hi-Z, Pull, Drive	Hi-Z
							5	I2C_SCL	I ² C clock	I/O (open drain)			
							7	GSPI_CLK	General SPI clock	I/O			
							4	pDATA8 (CAM_D4)	Parallel camera data bit 4	I			
							12	GT_CCP05	Timer capture port	I			

Table 6-1. Pin Attributes and Pin Multiplexing (continued)

GENERAL PIN ATTRIBUTES						FUNCTION					PAD STATES		
Pkg. Pin	Pin Alias	Use	Select as Wakeup Source	Config. Addl. Analog Mux	Muxed With JTAG	Dig. Pin Mux Config. Reg.	Dig. Pin Mux Config. Mode Value	Signal Name	Signal Description	Signal Direction	LPDS ⁽¹⁾	Hib ⁽²⁾	nRESET = 0
6	GPIO15	I/O	No	No	No	GPIO_PAD_CONFIG_15 (0x4402 E0DC)	0	GPIO15	GPIO	I/O	Hi-Z, Pull, Drive	Hi-Z, Pull, Drive	Hi-Z
							5	I2C_SDA	I ² C data	I/O (open drain)			
							7	GSPI_MISO	General SPI MISO	I/O			
							4	pDATA9 (CAM_D5)	Parallel camera data bit 5	I			
							13	GT_CCP06	Timer capture port	I			
							8	SDCARD_DATA0	SD card data	I/O			
7	GPIO16	I/O	No	No	No	GPIO_PAD_CONFIG_16 (0x4402 E0E0)	0	GPIO16	GPIO	I/O	Hi-Z, Pull, Drive	Hi-Z, Pull, Drive	Hi-Z
											Hi-Z, Pull, Drive		
											Hi-Z, Pull, Drive		
							7	GSPI_MOSI	General SPI MOSI	I/O	Hi-Z, Pull, Drive		
							4	pDATA10 (CAM_D6)	Parallel camera data bit 6	I	Hi-Z, Pull, Drive		
							5	UART1_TX	UART1 TX data	O	1		
							13	GT_CCP07	Timer capture port	I	Hi-Z, Pull, Drive		
							8	SDCARD_CLK	SD card clock	O	Zero		

Table 6-1. Pin Attributes and Pin Multiplexing (continued)

GENERAL PIN ATTRIBUTES						FUNCTION					PAD STATES		
Pkg. Pin	Pin Alias	Use	Select as Wakeup Source	Config. Addl. Analog Mux	Muxed With JTAG	Dig. Pin Mux Config. Reg.	Dig. Pin Mux Config. Mode Value	Signal Name	Signal Description	Signal Direction	LPDS ⁽¹⁾	Hib ⁽²⁾	nRESET = 0
8	GPIO17	I/O	Yes	No	No	GPIO_PAD_CONFIG_17 (0x4402 E0E4)	0	GPIO17	GPIO	I/O	Hi-Z, Pull, Drive	Hi-Z, Pull, Drive	Hi-Z
							5	UART1_RX	UART1 RX data	I			
							7	GSPI_CS	General SPI chip select	I/O			
							4	pDATA11 (CAM_D7)	Parallel camera data bit 7	I			
							8	SDCARD_CMD	SD card command line	I/O			
9	GPIO12	I/O	No	No	No	GPIO_PAD_CONFIG_12 (0x4402 E0D0)	0	GPIO12	GPIO	I/O	Hi-Z, Pull, Drive	Hi-Z, Pull, Drive	Hi-Z
							3	McACLK	I2S audio port clock output	O	Hi-Z, Pull, Drive		
							4	pVS (VSYNC)	Parallel camera vertical sync	I	Hi-Z, Pull, Drive		
							5	I2C_SCL	I ² C clock	I/O (open drain)	Hi-Z, Pull, Drive		
							7	UART0_TX	UART0 TX data	O	1		
							12	GT_CCP03	Timer capture port	I	Hi-Z, Pull, Drive		
10	GPIO13	I/O	Yes	No	No	GPIO_PAD_CONFIG_13 (0x4402 E0D4)	0	GPIO13	GPIO	I/O	Hi-Z, Pull, Drive	Hi-Z, Pull, Drive	Hi-Z
							5	I2C_SDA	I ² C data	I/O (open drain)			
							4	pHS (HSYNC)	Parallel camera horizontal sync	I			
							7	UART0_RX	UART0 RX data	I			
							12	GT_CCP04	Timer capture port	I			

Table 6-1. Pin Attributes and Pin Multiplexing (continued)

GENERAL PIN ATTRIBUTES						FUNCTION					PAD STATES		
Pkg. Pin	Pin Alias	Use	Select as Wakeup Source	Config. Addl. Analog Mux	Muxed With JTAG	Dig. Pin Mux Config. Reg.	Dig. Pin Mux Config. Mode Value	Signal Name	Signal Description	Signal Direction	LPDS ⁽¹⁾	Hib ⁽²⁾	nRESET = 0
11	GPIO22	I/O	No	No	No	GPIO_PAD_CONFIG_22 (0x4402 E0F8)	0	GPIO22	GPIO	I/O	Hi-Z, Pull, Drive	Hi-Z, Pull, Drive	Hi-Z
							7	McAFSX	I2S audio port frame sync	O			
							5	GT_CCP04	Timer capture port	I			
12	JTAG_TDI	I/O	No	No	Muxed with JTAG TDI	GPIO_PAD_CONFIG_23 (0x4402 E0FC)	1	TDI	JTAG TDI. Reset default pinout.	I	Hi-Z, Pull, Drive	Hi-Z, Pull, Drive	Hi-Z
							0	GPIO23	GPIO	I/O			
							2	UART1_TX	UART1 TX data	O	1		
							9	I2C_SCL	I2C clock	I/O (open drain)	Hi-Z, Pull, Drive		
13	FLASH_SPI_MISO	N/A	N/A	N/A	N/A	N/A	N/A	FLASH_SPI_MISO	Data from SPI serial flash (fixed default)	N/A	Hi-Z	Hi-Z	Hi-Z
14	FLASH_SPI_nCS_IN	N/A	N/A	N/A	N/A	N/A	N/A	FLASH_SPI_nCS_IN	Chip select to SPI serial flash (fixed default)	N/A	1	Hi-Z, Pull, Drive	Hi-Z
15	FLASH_SPI_CLK	N/A	N/A	N/A	N/A	N/A	N/A	FLASH_SPI_CLK	Clock to SPI serial flash (fixed default)	N/A	Hi-Z, Pull, Drive ⁽³⁾	Hi-Z, Pull, Drive	Hi-Z
16	GND	GND	N/A	N/A	N/A	N/A	N/A	GND	GND	N/A	N/A	N/A	N/A
17	FLASH_SPI_MOSI	N/A	N/A	N/A	N/A	N/A	N/A	FLASH_SPI_MOSI	Data to SPI serial flash (fixed default)	N/A	Hi-Z, Pull, Drive ⁽³⁾	Hi-Z, Pull, Drive	Hi-Z

Table 6-1. Pin Attributes and Pin Multiplexing (continued)

GENERAL PIN ATTRIBUTES						FUNCTION					PAD STATES		
Pkg. Pin	Pin Alias	Use	Select as Wakeup Source	Config. Addl. Analog Mux	Muxed With JTAG	Dig. Pin Mux Config. Reg.	Dig. Pin Mux Config. Mode Value	Signal Name	Signal Description	Signal Direction	LPDS ⁽¹⁾	Hib ⁽²⁾	nRESET = 0
18	JTAG_TDO	I/O	Yes	No	Muxed with JTAG TDO	GPIO_PAD_CONFIG_24 (0x4402 E100)	1	TDO	JTAG TDO. Reset default pinout.	O	Hi-Z, Pull, Drive	Driven high in SWD; driven low in 4-wire JTAG	Hi-Z
							0	GPIO24	GPIO	I/O			
							5	PWM0	Pulse-width modulated O/P	O			
							2	UART1_RX	UART1 RX data	I			
							9	I2C_SDA	I ² C data	I/O (open drain)			
							4	GT_CCP06	Timer capture port	I			
							6	McAFSX	I2S audio port frame sync	O			
19	GPIO28	I/O	No	No	No	GPIO_PAD_CONFIG_40 (0x4402 E140)	0	GPIO28	GPIO	I/O	Hi-Z, Pull, Drive	Hi-Z, Pull, Drive	Hi-Z
20	NC	WLAN analog	N/A	N/A	N/A	N/A	N/A	NC	Reserved	N/A	N/A	N/A	N/A
21	JTAG_TCK	I/O	No	No	Muxed with JTAG/SWD-TCK	GPIO_PAD_CONFIG_28 (0x4402 E110)	1	TCK	JTAG/SWD TCK. Reset default pinout.	I	Hi-Z, Pull, Drive	Hi-Z, Pull, Drive	Hi-Z
							8	GT_PWM03	Pulse-width modulated O/P	O			
22	JTAG_TMS	I/O	No	No	Muxed with JTAG/SWD-TMSC	GPIO_PAD_CONFIG_29 (0x4402 E114)	1	TMS	JTAG/SWD TMS. Reset default pinout.	I/O	Hi-Z, Pull, Drive	Hi-Z, Pull, Drive	Hi-Z
							0	GPIO29	GPIO				

Table 6-1. Pin Attributes and Pin Multiplexing (continued)

GENERAL PIN ATTRIBUTES						FUNCTION					PAD STATES		
Pkg. Pin	Pin Alias	Use	Select as Wakeup Source	Config. Addl. Analog Mux	Muxed With JTAG	Dig. Pin Mux Config. Reg.	Dig. Pin Mux Config. Mode Value	Signal Name	Signal Description	Signal Direction	LPDS ⁽¹⁾	Hib ⁽²⁾	nRESET = 0
23 ⁽⁴⁾	SOP2	O only	No	No	No	GPIO_PAD_CONFIG_25 (0x4402 E104)	0	GPIO25	GPIO	O	Hi-Z, Pull, Drive	Driven Low	Hi-Z
							9	GT_PWM02	Pulse-width modulated O/P	O	Hi-Z, Pull, Drive		
							2	McAFSX	I2S audio port frame sync	O	Hi-Z, Pull, Drive		
							See ⁽⁵⁾	TCXO_EN	Enable to optional external 40-MHz TCXO	O	0		
							See ⁽⁶⁾	SOP2	Sense-on-power 2	I	Hi-Z, Pull, Drive		
24	SOP1	Config sense	N/A	N/A	N/A	N/A	N/A	SOP1	Sense-on-power 1	N/A	N/A	N/A	N/A
25	GND	GND	N/A	N/A	N/A	N/A	N/A	GND	GND	N/A	N/A	N/A	N/A
26	GND	GND	N/A	N/A	N/A	N/A	N/A	GND	GND	N/A	N/A	N/A	N/A
27	GND	GND	N/A	N/A	N/A	N/A	N/A	GND	GND	N/A	N/A	N/A	N/A
28	GND	GND	N/A	N/A	N/A	N/A	N/A	GND	GND	N/A	N/A	N/A	N/A
29	GND	GND	N/A	N/A	N/A	N/A	N/A	GND	GND	N/A	N/A	N/A	N/A
30	GND	GND	N/A	N/A	N/A	N/A	N/A	GND	GND	N/A	N/A	N/A	N/A
31	RF_ABG	WLAN analog	N/A	N/A	N/A	N/A	N/A	CC3235MODx: RF ABG band	N/A	N/A	N/A	N/A	N/A
32	GND	GND	N/A	N/A	N/A	N/A	N/A	GND	GND	N/A	N/A	N/A	N/A
33	NC	WLAN analog	N/A	N/A	N/A	N/A		NC	Reserved				
34	SOP0	Config sense	N/A	N/A	N/A	N/A	N/A	SOP0	Sense-on-power 0	N/A	N/A	N/A	N/A
35	nRESET	Global reset	N/A	N/A	N/A	N/A	N/A	nRESET	Master chip reset. Active low.	N/A	N/A	N/A	N/A

Table 6-1. Pin Attributes and Pin Multiplexing (continued)

GENERAL PIN ATTRIBUTES						FUNCTION					PAD STATES		
Pkg. Pin	Pin Alias	Use	Select as Wakeup Source	Config. Addl. Analog Mux	Muxed With JTAG	Dig. Pin Mux Config. Reg.	Dig. Pin Mux Config. Mode Value	Signal Name	Signal Description	Signal Direction	LPDS ⁽¹⁾	Hib ⁽²⁾	nRESET = 0
36	VBAT_RESET	Global reset	N/A	N/A	N/A	N/A	N/A	VBAT_RESET	VBAT to nRESET pullup resistor	N/A	N/A	N/A	N/A
37	VBAT1	Supply input	N/A	N/A	N/A	N/A	N/A	VBAT1	Analog DC/DC input (connected to chip input supply [VBAT])	N/A	N/A	N/A	N/A
38	GND	GND	N/A	N/A	N/A	N/A	N/A	GND	GND	N/A	N/A	N/A	N/A
39	NC	WLAN analog	N/A	N/A	N/A	N/A	N/A	NC	Reserved	N/A	N/A	N/A	N/A
40	VBAT2	Supply input	N/A	N/A	N/A	N/A	N/A	VBAT2	Analog input supply VBAT	N/A	N/A	N/A	N/A
41	NC	WLAN analog	N/A	N/A	N/A	N/A	N/A	NC	Reserved	N/A	N/A	N/A	N/A
42	GPIO30	I/O	No	User config not required ⁽⁷⁾	No	GPIO_PAD_CONFIG_30 (0x4402 E118)	0	GPIO30	GPIO	I/O	Hi-Z, Pull, Drive	Hi-Z, Pull, Drive	Hi-Z
							9	UART0_TX	UART0 TX data	O	1		
							2	McACLK	I2S audio port clock	O	Hi-Z, Pull, Drive		
							3	McAFSX	I2S audio port frame sync	O	Hi-Z, Pull, Drive		
							4	GT_CCP05	Timer capture port	I	Hi-Z, Pull, Drive		
							7	GSPI_MISO	General SPI MISO	I/O	Hi-Z, Pull, Drive		
43	GND	GND	N/A	N/A	N/A	N/A	N/A	GND	GND	N/A	N/A	N/A	N/A

Table 6-1. Pin Attributes and Pin Multiplexing (continued)

GENERAL PIN ATTRIBUTES						FUNCTION					PAD STATES		
Pkg. Pin	Pin Alias	Use	Select as Wakeup Source	Config. Addl. Analog Mux	Muxed With JTAG	Dig. Pin Mux Config. Reg.	Dig. Pin Mux Config. Mode Value	Signal Name	Signal Description	Signal Direction	LPDS ⁽¹⁾	Hib ⁽²⁾	nRESET = 0
44	GPIO0	I/O	No	User config not required ⁽⁷⁾	No	GPIO_PAD_CONFIG_0 (0x4402 E0A0)	0	GPIO0	GPIO	I/O	Hi-Z, Pull, Drive	Hi-Z, Pull, Drive	Hi-Z
							12	UART0_CTS	UART0 Clear-to-Send input (active low)	I	Hi-Z, Pull, Drive		
							6	McAXR1	I2S audio port data 1 (RX/TX)	I/O	Hi-Z, Pull, Drive		
							7	GT_CCP00	Timer capture port	I	Hi-Z, Pull, Drive		
							9	GSPI_CS	General SPI chip select	I/O	Hi-Z, Pull, Drive		
							10	UART1_RTS	UART1 Request-to-Send (active low)	O	1		
							3	UART0_RTS	UART0 Request-to-Send (active low)	O	1		
							4	McAXR0	I2S audio port data 0 (RX/TX)	I/O	Hi-Z, Pull, Drive		
45	NC	WLAN analog	N/A	N/A	N/A	N/A	N/A	NC	Reserved	N/A	N/A	N/A	N/A
46	GPIO1	I/O	No	No	No	GPIO_PAD_CONFIG_1 (0x4402 E0A4)	0	GPIO1	GPIO	I/O	Hi-Z, Pull, Drive	Hi-Z, Pull, Drive	Hi-Z
							3	UART0_TX	UART0 TX data	O	1		
							4	pCLK (PIXCLK)	Pixel clock from parallel camera sensor	I	Hi-Z, Pull, Drive		
							6	UART1_TX	UART1 TX data	O	1		
							7	GT_CCP01	Timer capture port	I	Hi-Z, Pull, Drive		

Table 6-1. Pin Attributes and Pin Multiplexing (continued)

GENERAL PIN ATTRIBUTES						FUNCTION					PAD STATES		
Pkg. Pin	Pin Alias	Use	Select as Wakeup Source	Config. Addl. Analog Mux	Muxed With JTAG	Dig. Pin Mux Config. Reg.	Dig. Pin Mux Config. Mode Value	Signal Name	Signal Description	Signal Direction	LPDS ⁽¹⁾	Hib ⁽²⁾	nRESET = 0
47 ⁽⁹⁾	GPIO2	Analog input (up to 1.8 V)/ digital I/O	Yes	See ⁽⁸⁾	No	GPIO_PAD_CONFIG_2 (0x4402 E0A8)	See ⁽⁵⁾	ADC_CH0	ADC channel 0 input (1.5-V max)	I	Hi-Z, Pull, Drive	Hi-Z, Pull, Drive	Hi-Z
							0	GPIO2	GPIO	I/O	Hi-Z, Pull, Drive		
							3	UART0_RX	UART0 RX data	I	Hi-Z, Pull, Drive		
							6	UART1_RX	UART1 RX data	I	Hi-Z, Pull, Drive		
							7	GT_CCP02	Timer capture port	I	Hi-Z, Pull, Drive		
48 ⁽⁹⁾	GPIO3	Analog input (up to 1.8 V)/ digital I/O	No	See ⁽⁸⁾	No	GPIO_PAD_CONFIG_3 (0x4402 E0AC)	See ⁽⁵⁾	ADC_CH1	ADC channel 1 input (1.5-V max)	I	Hi-Z, Pull, Drive	Hi-Z, Pull, Drive	Hi-Z
							0	GPIO3	GPIO	I/O	Hi-Z, Pull, Drive		
							6	UART1_TX	UART1 TX data	O	1		
							4	pDATA7 (CAM_D3)	Parallel camera data bit 3	I	Hi-Z, Pull, Drive		

Table 6-1. Pin Attributes and Pin Multiplexing (continued)

GENERAL PIN ATTRIBUTES						FUNCTION					PAD STATES		
Pkg. Pin	Pin Alias	Use	Select as Wakeup Source	Config. Addl. Analog Mux	Muxed With JTAG	Dig. Pin Mux Config. Reg.	Dig. Pin Mux Config. Mode Value	Signal Name	Signal Description	Signal Direction	LPDS ⁽¹⁾	Hib ⁽²⁾	nRESET = 0
49 ⁽⁹⁾	GPIO4	Analog input (up to 1.8 V)/ digital I/O	Yes	See ⁽⁸⁾	Yes	GPIO_PAD_CONFIG_4 (0x4402 E0B0)	See ⁽⁵⁾	ADC_CH2	ADC channel 2 input (1.5-V max)	I	Hi-Z, Pull, Drive	Hi-Z, Pull, Drive	Hi-Z
							0	GPIO4	GPIO	I/O	Hi-Z, Pull, Drive		
							6	UART1_RX	UART1 RX data	I	Hi-Z, Pull, Drive		
							4	pDATA6 (CAM_D2)	Parallel camera data bit 2	I	Hi-Z, Pull, Drive		
50 ⁽⁹⁾	GPIO5	Analog input up to 1.5 V	No	See ⁽⁸⁾	No	GPIO_PAD_CONFIG_5 (0x4402 E0B4)	See ⁽⁵⁾	ADC_CH3	ADC channel 3 input (1.5 V max)	I	i-Z, Pull, Drive	Hi-Z, Pull, Drive	Hi-Z
							0	GPIO5	GPIO	I/O	Hi-Z, Pull, Drive		
							4	pDATA5 (CAM_D1)	Parallel camera data bit 1	I	Hi-Z, Pull, Drive		
							6	McAXR1	I2S audio port data 1 (RX, TX)	I/O	Hi-Z, Pull, Drive		
							7	GT_CCP05	Timer capture port	I	Hi-Z, Pull, Drive		

Table 6-1. Pin Attributes and Pin Multiplexing (continued)

GENERAL PIN ATTRIBUTES						FUNCTION					PAD STATES		
Pkg. Pin	Pin Alias	Use	Select as Wakeup Source	Config. Addl. Analog Mux	Muxed With JTAG	Dig. Pin Mux Config. Reg.	Dig. Pin Mux Config. Mode Value	Signal Name	Signal Description	Signal Direction	LPDS ⁽¹⁾	Hib ⁽²⁾	nRESET = 0
51	GPIO6	I/O	No	No	No	GPIO_PAD_CONFIG_6 (0x4402 E0B8)	0	GPIO6	GPIO	I/O	Hi-Z, Pull, Drive	Hi-Z, Pull, Drive	Hi-Z
							5	UART0_RTS	UART0 Request-to-Send (active low)	O	1		
							4	pDATA4 (CAM_D0)	Parallel camera data bit 0	I	Hi-Z, Pull, Drive		
							3	UART1_CTS	UART1 Clear to send (active low)	I	Hi-Z, Pull, Drive		
							6	UART0_CTS	UART0 Clear to send (active low)	I	Hi-Z, Pull, Drive		
							7	GT_CCP06	Timer capture port	I	Hi-Z, Pull, Drive		
52	GPIO7	I/O	No	No	No	GPIO_PAD_CONFIG_7 (0x4402 E0BC)	0	GPIO7	GPIO	I/O	Hi-Z, Pull, Drive	Hi-Z, Pull, Drive	Hi-Z
							13	McACLK	I2S audio port clock	O	Hi-Z, Pull, Drive		
							3	UART1_RTS	UART1 Request to send (active low)	O	1		
							10	UART0_RTS	UART0 Request to send (active low)	O	1		
							11	UART0_TX	UART0 TX data	O	1		
53	GPIO8	I/O	No	No	No	GPIO_PAD_CONFIG_8 (0x4402 E0C0)	0	GPIO8	GPIO	I/O	Hi-Z, Pull, Drive	Hi-Z, Pull, Drive	Hi-Z
							6	SDCARD_IRQ	Interrupt from SD card (future support)	I			
							7	McAFSX	I2S audio port frame sync	O			
							12	GT_CCP06	Timer capture port	I			

Table 6-1. Pin Attributes and Pin Multiplexing (continued)

GENERAL PIN ATTRIBUTES						FUNCTION					PAD STATES		
Pkg. Pin	Pin Alias	Use	Select as Wakeup Source	Config. Addl. Analog Mux	Muxed With JTAG	Dig. Pin Mux Config. Reg.	Dig. Pin Mux Config. Mode Value	Signal Name	Signal Description	Signal Direction	LPDS ⁽¹⁾	Hib ⁽²⁾	nRESET = 0
54	GPIO9	I/O	No	No	No	GPIO_PAD_CONFIG_9 (0x4402 E0C4)	0	GPIO9	GPIO	I/O	Hi-Z, Pull, Drive	Hi-Z, Pull, Drive	Hi-Z
							3	GT_PWM05	Pulse-width modulated O/P	O			
							6	SDCARD_DATA0	SD card data	I/O			
							7	McAXR0	I2S audio port data (RX, TX)	I/O			
							12	GT_CCP00	Timer capture port	I			
55	GND	GND	N/A	N/A	N/A	N/A	N/A	GND	GND	N/A	N/A	N/A	N/A
56	GND	GND	N/A	N/A	N/A	N/A	N/A	GND	GND	N/A	N/A	N/A	N/A
57	GND	GND	N/A	N/A	N/A	N/A	N/A	GND	GND	N/A	N/A	N/A	N/A
58	GND	GND	N/A	N/A	N/A	N/A	N/A	GND	GND	N/A	N/A	N/A	N/A
59	GND	GND	N/A	N/A	N/A	N/A	N/A	GND	GND	N/A	N/A	N/A	N/A
60	GND	GND	N/A	N/A	N/A	N/A	N/A	GND	GND	N/A	N/A	N/A	N/A
61	GND	GND	N/A	N/A	N/A	N/A	N/A	GND	GND	N/A	N/A	N/A	N/A
62	GND	GND	N/A	N/A	N/A	N/A	N/A	GND	GND	N/A	N/A	N/A	N/A
63	GND	GND	N/A	N/A	N/A	N/A	N/A	GND	GND	N/A	N/A	N/A	N/A

- (1) LPDS state: The state of unused I/Os is Hi-Z. Software may program the I/Os to be input with pull or drive (regardless of active pin configuration), according to the need.
- (2) Hibernate mode: The state of the I/Os is Hi-Z. Software may program the I/Os to be input with pull or drive (regardless of active pin configuration), according to the need.
- (3) To minimize leakage in some serial flash vendors during LPDS, TI recommends that the user application always enables internal weak pulldowns on FLASH_SPI_DIN, FLASH_SPI_DOUT, and FLASH_SPI_CLK pins.
- (4) Pin has dual functions: as a SOP[2] (device operation mode), and as an external TCXO enable. As a TCXO enable, the pin is an output on power up and driven logic high. During hibernate low-power mode, the pin is in a Hi-Z state but is pulled down for SOP mode to disable TCXO. Because of the SOP functionality, the pin must be used as an output only.
- (5) For details on proper use, see [Drive Strength and Reset States for Analog-Digital Multiplexed Pins](#).
- (6) Pin is one of three that must have a passive pullup or pulldown resistor onboard to configure the chip hardware power-up mode. For this reason, the pin must be output only when used for digital functions.
- (7) Device firmware automatically enables the digital path during ROM boot.
- (8) Requires user configuration to enable the analog switch of the ADC channel. (The switch is off by default.) The digital I/O is always connected and must be made Hi-Z before enabling the ADC switch.
- (9) Pin is shared by the ADC inputs and digital I/O pad cells.

Note

The ADC inputs are tolerant up to 1.8V (see [Section 7.16.5.6](#) for further details on the useable range of the ADC). The digital pads can tolerate up to 3.6V. Hence, take care to prevent accidental damage to the ADC inputs. TI recommends first disabling the output buffers of the digital I/Os corresponding to the desired ADC channel (that is, converted to Hi-Z state), and thereafter disabling the respective pass switches (S7 [Pin 47], S8 [Pin 48], S9 [Pin 49], and S10 [Pin 50]). For more information, see [Drive Strength and Reset States for Analog-Digital Multiplexed Pins](#).

6.3 Signal Descriptions

Table 6-2. Signal Descriptions

FUNCTION	SIGNAL NAME	PIN NO.	PIN TYPE	SIGNAL DIRECTION	DESCRIPTION
ADC	ADC_CH0	47	I/O	I	ADC channel 0 input (maximum of 1.5 V)
	ADC_CH1	48	I/O	I	ADC channel 1 input (maximum of 1.5 V)
	ADC_CH2	49	I/O	I	ADC channel 2 input (maximum of 1.5 V)
	ADC_CH3	50	I	I	ADC channel 3 input (maximum of 1.5 V)
BLE/2.4 GHz radio coexistence ⁽²⁾	GPIO10	3	I/O	I/O	Coexistence inputs and outputs
	GPIO14	5	I/O	I/O	
	GPIO15	6	I/O	I/O	
	GPIO16	7	I/O	I/O	
	GPIO17	8	I/O	I/O	
	GPIO12	9	I/O	I/O	
	GPIO22	11	I/O	I/O	
	GPIO28	19 ⁽¹⁾	I/O	I/O	
	GPIO0	44	I/O	I/O	
	GPIO30	42 ⁽¹⁾	I/O	I/O	
	GPIO5	50	I/O	I/O	
	GPIO6	51	I/O	I/O	
	GPIO8	53	I/O	I/O	
GPIO9	54	I/O	I/O		
Hostless mode	HM_IO	3	I/O	I/O	Hostless mode inputs and outputs
		4	I/O	O	
		5	I/O	I/O	
		6	I/O	I/O	
		7	I/O	I/O	
		8	I/O	I/O	
		9	I/O	I/O	
		10	I/O	O	
		11	I/O	I/O	
		19 ⁽¹⁾	I/O	I/O	
		23	O	O	
		42 ⁽¹⁾	I/O	I/O	
		44	I/O	I/O	
		48	O	O	
		49	O	O	
50	I/O	I/O			
51	I/O	I/O			
53	I/O	I/O			
54	I/O	I/O			
JTAG / SWD	TDI	12	I/O	I	JTAG TDI. Reset default pinout.
	TDO	18	I/O	O	JTAG TDO. Reset default pinout.
	TCK	21	I/O	I	JTAG/SWD TCK. Reset default pinout.
	TMS	22	I/O	I/O	JTAG/SWD TMS. Reset default pinout.

Table 6-2. Signal Descriptions (continued)

FUNCTION	SIGNAL NAME	PIN NO.	PIN TYPE	SIGNAL DIRECTION	DESCRIPTION
I ² C	I2C_SCL	3	I/O	I/O (open drain)	I ² C clock data
		5			
		9			
		12			
	I2C_SDA	4	I/O	I/O (open drain)	I ² C data
		6			
		10			
		18			
Timers	GT_PWM06	3	I/O	O	Pulse-width modulated O/P
	GT_CCP01	46	I/O	I	Timer capture port
	GT_PWM07	4	I/O	O	Pulse-width modulated O/P
	GT_CCP02	47	I/O	I	Timer capture ports
	GT_CCP03	9	I/O	I	
	GT_CCP04	10	I/O	I	
		11	I/O	I	
	GT_CCP05	5	I/O	I	
	GT_CCP06	6	I/O	I	
		18	I/O	I	
		51	I/O	I	
		53	I/O	I	
	GT_CCP07	7	I/O	I	
	PWM0	18	I/O	O	
	GT_PWM03	21	I/O	O	
	GT_PWM02	23	O	O	Timer capture ports
		GT_CCP00	44	I/O	
	GT_CCP00	54	I/O	I	
		GT_CCP05	42	I/O	
	GT_CCP01	46	I/O	I	
GT_CCP02	47	I/O	I		
GT_CCP05	50	I	I	Timer capture port Input	
GT_PWM05	54	I/O	O	Pulse-width modulated output	

Table 6-2. Signal Descriptions (continued)

FUNCTION	SIGNAL NAME	PIN NO.	PIN TYPE	SIGNAL DIRECTION	DESCRIPTION
GPIO	GPIO10	3	I/O	I/O	General-purpose inputs or outputs
	GPIO11	4	I/O	I/O	
	GPIO14	5	I/O	I/O	
	GPIO15	6	I/O	I/O	
	GPIO16	7	I/O	I/O	
	GPIO17	8	I/O	I/O	
	GPIO12	9	I/O	I/O	
	GPIO13	10	I/O	I/O	
	GPIO22	11	I/O	I/O	
	GPIO23	12	I/O	I/O	
	GPIO24	18	I/O	I/O	
	GPIO28	19	I/O	I/O	
	GPIO29	22	I/O	I/O	
	GPIO25	23	O	O	
	GPIO0	44	I/O	I/O	
	GPIO30	42	I/O	I/O	
	GPIO1	46	I/O	I/O	
	GPIO2	47	I/O	I/O	
	GPIO3	48	I/O	I/O	
	GPIO4	49	I/O	I/O	
	GPIO5	50	I/O	I/O	
GPIO6	51	I/O	I/O		
GPIO7	52	I/O	I/O		
GPIO8	53	I/O	I/O		
GPIO9	54	I/O	I/O		
McASP I ² S or PCM	MCAFSX	4	I/O	O	I ² S audio port frame sync
		11			
		18			
		23			
		42			
		53			
	McACLK	9	I/O	O	I ² S audio port clock outputs
		42	I/O	O	
	McAXR1	44	I/O	I/O	I ² S audio port data 1 (RX/TX)
		50	I	I/O	I ² S audio port data 1 (RX and TX)
	McAXR0	44	I/O	I/O	I ² S audio port data 0 (RX and TX)
54		I/O	I/O	I ² S audio port data (RX and TX)	
McACLKX	52	I/O	O	I ² S audio port clock	

Table 6-2. Signal Descriptions (continued)

FUNCTION	SIGNAL NAME	PIN NO.	PIN TYPE	SIGNAL DIRECTION	DESCRIPTION
Multimedia card (MMC or SD)	SDCARD_CLK	3	I/O	O	SD card clock data
		7			
	SDCARD_CMD	4	I/O	I/O (open drain)	SD card command line
		8	I/O	I/O	
	SDCARD_DATA0	6	I/O	I/O	SD card data
54					
SDCARD_IRQ	53	I/O	I	Interrupt from SD card ⁽³⁾	
Parallel interface (8-bit π)	pXCLK (XVCLK)	4	I/O	O	Free clock to parallel camera
	pVS (VSYNC)	9	I/O	I	Parallel camera vertical sync
	pHS (HSYNC)	10	I/O	I	Parallel camera horizontal sync
	pDATA8 (CAM_D4)	5	I/O	I	Parallel camera data bit 4
	pDATA9 (CAM_D5)	6	I/O	I	Parallel camera data bit 5
	pDATA10 (CAM_D6)	7	I/O	I	Parallel camera data bit 6
	pDATA11 (CAM_D7)	8	I/O	I	Parallel camera data bit 7
	pCLK (PIXCLK)	46	I/O	I	Pixel clock from parallel camera sensor
	pDATA7 (CAM_D3)	48	I/O	I	Parallel camera data bit 3
	pDATA6 (CAM_D2)	49	I/O	I	Parallel camera data bit 2
	pDATA5 (CAM_D1)	50	I	I	Parallel camera data bit 1
pDATA4 (CAM_D0)	51	I/O	I	Parallel camera data bit 0	
Power	VBAT1	37	—	—	Power supply for the module
	VBAT2	40	—	—	Power supply for the module
RF ⁽⁴⁾	RF_ABG	31	I/O	I	WLAN analog RF 802.11 a/b/g/n bands
SPI	GSPI_CLK	5	I/O	I/O	General SPI clock
		6	I/O	I/O	
	GSPI_MISO	42	I/O	I/O	General SPI MISO
		8	I/O	I/O	
	GSPI_CS	44	I/O	I/O	General SPI device select
7		I/O	I/O		
FLASH SPI	FLASH_SPI_CLK	15	O	O	Clock to SPI serial flash (fixed default)
	FLASH_SPI_DOUT	17	O	O	Data to SPI serial flash (fixed default)
	FLASH_SPI_DIN	13	I	I	Data from SPI serial flash (fixed default)
	FLASH_SPI_CS	14	O	O	Device select to SPI serial flash (fixed default)

Table 6-2. Signal Descriptions (continued)

FUNCTION	SIGNAL NAME	PIN NO.	PIN TYPE	SIGNAL DIRECTION	DESCRIPTION
UART	UART1_TX	3	I/O	O	UART TX data
		7	I/O	O	
		12	I/O	O	
		46	I/O	O	
		48	I/O	O	UART1 TX data
	UART1_RX	4	I/O	I	UART RX data
		8	I/O	I	
		18	I/O	I	
		47	I/O	I	UART1 RX data
		49	I/O	I	
	UART1_RTS	44	I/O	O	UART1 request-to-send (active low)
		52	I/O	O	
	UART1_CTS	51	I/O	I	UART1 clear-to-send (active low)
	UART0_TX	9	I/O	O	UART0 TX data
		42	I/O	O	
		46	I/O	O	
		52	I/O	O	
	UART0_RX	10	I/O	I	UART0 RX data
		47	I/O	I	UART0 RX data
	UART0_CTS	44	I/O	I	UART0 clear-to-send input (active low)
51					
UART0_RTS	44	I/O	O	UART0 request-to-send (active low)	
	51	I/O	O		
	52	I/O	O		
Sense-On-Power	SOP2	23 ⁽⁵⁾	O	I	Sense-on-power 2
	SOP1	24	I	I	Configuration sense-on-power 1
	SOP0	34	I	I	Configuration sense-on-power 0

- (1) LPDS retention is unavailable.
- (2) The CC3235MODx or CC3235MODAx modules are compatible with TI BLE modules using an external RF switch.
- (3) Future support.
- (4) This pin is not accessible on the CC3235MODAx devices as it is directly tied to the integrated antenna.
- (5) This pin has dual functions: as a SOP[2] (device operation mode), and as an external TCXO enable. As a TCXO enable, the pin is an output on power up and driven logic high. During hibernate low-power mode, the pin is in a Hi-Z state but is pulled down for SOP mode to disable TCXO. Because of the SOP functionality, the pin must be used as an output only.

6.4 Drive Strength and Reset States for Analog-Digital Multiplexed Pins

Table 6-3 describes the use, drive strength, and default state of analog- and digital-multiplexed pins at first-time power up and reset (nRESET pulled low).

Table 6-3. Drive Strength and Reset States for Analog-Digital Multiplexed Pins

PIN	BOARD LEVEL CONFIGURATION AND USE	DEFAULT STATE AT FIRST POWER UP OR FORCED RESET	STATE AFTER CONFIGURATION OF ANALOG SWITCHES (ACTIVE, LPDS, and HIB POWER MODES)	MAXIMUM EFFECTIVE DRIVE STRENGTH (mA)
42	Generic I/O	Analog is isolated. The digital I/O cell is also isolated.	Determined by the I/O state, as are other digital I/Os.	4
44	Generic I/O	Analog is isolated. The digital I/O cell is also isolated.	Determined by the I/O state, as are other digital I/Os.	4
47	Analog signal (1.8-V absolute, 1.46-V full scale)	ADC is isolated. The digital I/O cell is also isolated.	Determined by the I/O state, as are other digital I/Os.	4
48	Analog signal (1.8-V absolute, 1.46-V full scale)	ADC is isolated. The digital I/O cell is also isolated.	Determined by the I/O state, as are other digital I/Os.	4
49	Analog signal (1.8-V absolute, 1.46-V full scale)	ADC is isolated. The digital I/O cell is also isolated.	Determined by the I/O state, as are other digital I/Os.	4
50	Analog signal (1.8-V absolute, 1.46-V full scale)	ADC is isolated. The digital I/O cell is also isolated.	Determined by the I/O state, as are other digital I/Os.	4

6.5 Pad State After Application of Power to Chip, but Before Reset Release

When a stable power is applied to the CC3235MODx or CC3235MODAx module for the first time or when supply voltage is restored to the proper value following a prior period with supply voltage below 1.5 V, the level of the digital pads are undefined in the period starting from the release of nRESET and until the DIG_DCDC of the CC3235x chip powers up. This period is less than approximately 10 ms. During this period, pads can be internally pulled weakly in either direction. If a certain set of pins are required to have a definite value during this pre-reset period, an appropriate pullup or pulldown must be used at the board level. The recommended value of these external pullup or pulldown resistors is 2.7 kΩ.

6.6 Connections for Unused Pins

All unused pin should be configured as stated in Table 6-4.

Table 6-4. Connections for Unused Pins

FUNCTION	SIGNAL DESCRIPTION	PIN NUMBER	ACCEPTABLE PRACTICE
GPIO	General-purpose input or output		Wake up I/O source should not be floating during hibernate. All the I/O pins will float while in Hibernate and Reset states. Ensure pullup and pulldown resistors are available on board to maintain the state of the I/O. Leave unused GPIOs as NC
No Connect	NC	20, 31 ⁽¹⁾ , 33, 39, 41, 45	Unused pin, leave as NC.
SOP	Configuration sense-on-power	23, 24, 34	Leave as NC (Modules contain internal 100-kΩ pulldown resistors on the SOP lines). An external 10-kΩ pullup resistor is required to pull these pins high. See Section 8.11.1 for SOP[2:0] configuration modes.
Reset	RESET input for the device		Never leave the reset pin floating
JTAG	JTAG interface		Leave as NC if unused

(1) The CC3235MODAx's RF_ABG pin is a NC as it is directly tied to the integrated PCB antenna.

7 Specifications

7.1 Absolute Maximum Ratings

All measurements are referenced at the module pins unless otherwise indicated. All specifications are over process and voltage unless otherwise indicated.

Over operating free-air temperature range (unless otherwise noted)^{(1) (2)}

	MIN	MAX	UNIT
V _{BAT}	-0.5	3.8	V
Digital I/O	-0.5	V _{BAT} + 0.5	V
RF pin	-0.5	2.1	V
Analog pins	-0.5	2.1	V
Operating temperature (T _A)	-40	85	°C
Storage temperature (T _{stg})	-40	85	°C
Junction temperature (T _j) ⁽³⁾		120	°C

- (1) Stresses beyond those listed under *Absolute Maximum Ratings* may cause permanent damage to the device. These are stress ratings only, and functional operation of the device at these or any other conditions beyond those indicated under *Recommended Operating Conditions* is not implied. Exposure to absolute-maximum-rated conditions for extended periods may affect device reliability.
- (2) All voltage values are with respect to V_{SS}, unless otherwise noted.
- (3) Junction temperature is for the CC3235x device that is contained within the module.

7.2 ESD Ratings

		VALUE	UNIT
V _{ESD}	Electrostatic discharge	Human body model (HBM), per ANSI/ESDA/JEDEC JS001 ⁽¹⁾	±2000
		Charged device model (CDM), per JESD22-C101 ⁽²⁾	±500
		All pins	V

- (1) JEDEC document JEP155 states that 500-V HBM allows safe manufacturing with a standard ESD control process.
- (2) JEDEC document JEP157 states that 250-V CDM allows safe manufacturing with a standard ESD control process.

7.3 Recommended Operating Conditions

Over operating free-air temperature range (unless otherwise noted)^{(2) (1) (3)}

	MIN	TYP	MAX	UNIT
V _{BAT}	2.3	3.3	3.6	V
Operating temperature	-40	25	85	°C
Ambient thermal slew	-20		20	°C/minute

- (1) When operating at an ambient temperature of over 75°C, the transmit duty cycle must remain below 50% to avoid the auto-protect feature of the power amplifier. If the auto-protect feature triggers, the device takes a maximum of 60 seconds to restart the transmission.
- (2) To ensure WLAN performance, the ripple on the power supply must be less than ±300 mV. The ripple should not cause the supply to fall below the brownout voltage.
- (3) The minimum voltage specified includes the ripple on the supply voltage and all other transient dips. The brownout condition is also 2.1 V, and care must be taken when operating at the minimum specified voltage.

7.4 Current Consumption (CC3235MODS and CC3235MODAS)

Table 7-1. Current Consumption Summary (CC3235MODS and CC3235MODAS) 2.4GHz RF Band

T_A = 25°C, V_{BAT} = 3.6 V

PARAMETER		TEST CONDITIONS ^{(1) (5)}		MIN	TYP ⁽⁶⁾	MAX	UNIT
MCU ACTIVE	NWP ACTIVE	TX	1 DSSS	TX power level = 0		272	mA
				TX power level = 4		190	
			6 OFDM	TX power level = 0		248	
				TX power level = 4		182	
			54 OFDM	TX power level = 0		223	
				TX power level = 4		160	
		RX	1 DSSS		59		
			54 OFDM		59		
NWP idle connected ⁽³⁾					15.3		
MCU SLEEP	NWP ACTIVE	TX	1 DSSS	TX power level = 0		269	mA
				TX power level = 4		187	
			6 OFDM	TX power level = 0		245	
				TX power level = 4		179	
			54 OFDM	TX power level = 0		220	
				TX power level = 4		157	
		RX	1 DSSS		56		
			54 OFDM		56		
NWP idle connected ⁽³⁾					12.2		
MCU LPDS	NWP ACTIVE	TX	1 DSSS	TX power level = 0		266	mA
				TX power level = 4		184	
			6 OFDM	TX power level = 0		242	
				TX power level = 4		176	
			54 OFDM	TX power level = 0		217	
				TX power level = 4		154	
		RX	1 DSSS		53		
			54 OFDM		53		
	NWP LPDS ⁽²⁾	SRAM Retention	64 KB		120	μA	
			256 KB		135		
NWP idle connected ⁽³⁾					710		
MCU SHUTDOWN	MCU shutdown				1	μA	
MCU HIBERNATE	MCU hibernate				5.5	μA	
Peak calibration current ⁽⁴⁾	V _{BAT} = 3.6 V				420	mA	
	V _{BAT} = 3.3 V				450		
	V _{BAT} = 2.3 V				610		

- (1) TX power level = 0 implies maximum power (see [Figure 7-1](#), [Figure 7-2](#), and [Figure 7-3](#)). TX power level = 4 implies output power backed off approximately 4 dB.
- (2) LPDS current does not include the external serial flash. The CC3235MODS and CC3235MODAS device can be configured to retain 0 KB, 64 KB, 128 KB, 192 KB, or 256 KB of SRAM in LPDS. Each 64-KB block of MCU retained SRAM increases LPDS current by 4 μA.
- (3) DTIM = 1
- (4) The complete calibration can take up to 17 mJ of energy from the battery over a time of 24 ms. In default mode, calibration is performed sparingly, and typically occurs when re-enabling the NWP and when the temperature has changed by more than 20°C. There are two additional calibration modes that may be used to reduced or completely eliminate the calibration event. For further details, see [CC31xx, CC32xx SimpleLink™ Wi-Fi® and IoT Network Processor Programmer's Guide](#).
- (5) The CC3235MODS and CC3235MODAS system is a constant power-source system. The active current numbers scale based on the V_{BAT} voltage supplied.

(6) Typical numbers assume a VSWR of 1.5:1.

Table 7-2. Current Consumption Summary (CC3235MODS and CC3235MODAS) 5 GHz RF Band

T_A = 25°C, V_{BAT} = 3.6 V

PARAMETER		TEST CONDITIONS ^{(1) (4)}		MIN	TYP ⁽⁵⁾	MAX	UNIT
MCU ACTIVE	NWP ACTIVE	TX	6 OFDM		318		mA
			54 OFDM		293		
		RX	54 OFDM		67		
	NWP idle connected ⁽³⁾				15.3		
MCU SLEEP	NWP ACTIVE	TX	6 OFDM		315		mA
			54 OFDM		290		
		RX	54 OFDM		64		
	NWP idle connected ⁽³⁾				12.2		
MCU LPDS	NWP ACTIVE	TX	6 OFDM		312		mA
			54 OFDM		287		
		RX	54 OFDM		61		
	NWP LPDS ⁽²⁾	SRAM Retention	64 KB		120		µA
			256 KB		135		
NWP idle connected ⁽³⁾				710			
MCU SHUTDOWN	MCU shutdown				1		µA
MCU HIBERNATE	MCU hibernate				5.5		µA
Peak calibration current ⁽⁶⁾	V _{BAT} = 3.6 V				290		mA
	V _{BAT} = 3.3 V				310		
	V _{BAT} = 2.7 V				310		
	V _{BAT} = 2.3 V				365		

- (1) Measurements taken at maximum TX power
- (2) LPDS current does not include the external serial flash. The CC3235MODx and CC3235MODAx can be configured to retain 0 KB, 64 KB, 128 KB, 192 KB, or 256 KB of SRAM in LPDS. Each 64-KB block of MCU retained SRAM increases LPDS current by 4 µA.
- (3) DTIM = 1
- (4) The CC3235MODx and CC3235MODAx system is a constant power-source system. The active current numbers scale based on the V_{BAT} voltage supplied.
- (5) Typical numbers assume a VSWR of 1.5:1.
- (6) The complete calibration can take up to 17 mJ of energy from the battery over a time of 24 ms. In default mode, calibration is performed sparingly, and typically occurs when re-enabling the NWP and when the temperature has changed by more than 20°C. There are two additional calibration modes that may be used to reduced or completely eliminate the calibration event. For further details, see [CC31xx](#), [CC32xx SimpleLink™ Wi-Fi® and IoT Network Processor Programmer's Guide](#).

7.5 Current Consumption (CC3235MODSF and CC3235MODASF)

Table 7-3. Current Consumption Summary (CC3235MODSF and CC3235MODASF) 2.4GHz RF Band

T_A = 25°C, V_{BAT} = 3.6 V

PARAMETER		TEST CONDITIONS ^{(1) (5)}		MIN	TYP ⁽⁵⁾	MAX	UNIT
MCU ACTIVE	NWP ACTIVE	TX	1 DSSS	TX power level = 0		286	mA
				TX power level = 4		202	
			6 OFDM	TX power level = 0		255	
				TX power level = 4		192	
			54 OFDM	TX power level = 0		232	
				TX power level = 4		174	
		RX	1 DSSS		74		
			54 OFDM		74		
NWP idle connected ⁽³⁾						25.2	
MCU SLEEP	NWP ACTIVE	TX	1 DSSS	TX power level = 0		282	mA
				TX power level = 4		198	
			6 OFDM	TX power level = 0		251	
				TX power level = 4		188	
			54 OFDM	TX power level = 0		228	
				TX power level = 4		170	
		RX	1 DSSS		70		
			54 OFDM		70		
NWP idle connected ⁽³⁾						21.2	
MCU LPDS	NWP active	TX	1 DSSS	TX power level = 0		266	mA
				TX power level = 4		184	
			6 OFDM	TX power level = 0		242	
				TX power level = 4		176	
			54 OFDM	TX power level = 0		217	
				TX power level = 4		154	
		RX	1 DSSS		53		
			54 OFDM		53		
	NWP LPDS ⁽²⁾	SRAM Retention	64 KB		120	μA	
			256 KB		135		
NWP idle connected ⁽³⁾						710	
MCU SHUTDOWN	MCU shutdown				1	μA	
MCU HIBERNATE	MCU hibernate				5.5	μA	
Peak calibration current ⁽⁴⁾	V _{BAT} = 3.6 V				420	mA	
	V _{BAT} = 3.3 V				450		
	V _{BAT} = 2.3 V				610		

- (1) TX power level = 0 implies maximum power (see [Figure 7-2](#), [Figure 7-2](#), and [Figure 7-3](#)). TX power level = 4 implies output power backed off approximately 4dB.
- (2) LPDS current does not include the external serial flash. The CC3235MODx and CC3235MODAx can be configured to retain 0KB, 64KB, 128KB, 192KB, or 256KB of SRAM in LPDS. Each 64-KB block of MCU retained SRAM increases LPDS current by 4μA.
- (3) DTIM = 1
- (4) The complete calibration can take up to 17 mJ of energy from the battery over a period of 24 ms. Calibration is performed sparingly, typically when coming out of HIBERNATE, and only if the temperature has changed by more than 20°C. The calibration event can be controlled by a configuration file in the serial flash.
- (5) Typical numbers assume a VSWR of 1.5:1.

Table 7-4. Current Consumption Summary (CC3235MODS and CC3235MODAS) 5 GHz RF Band

$T_A = 25^\circ\text{C}$, $V_{BAT} = 3.6\text{ V}$

PARAMETER		TEST CONDITIONS ^{(1) (4)}		MIN	TYP ⁽⁴⁾	MAX	UNIT
MCU ACTIVE	NWP ACTIVE	TX	6 OFDM		329		mA
			54 OFDM		306		
	RX	54 OFDM		80			
	NWP idle connected ⁽³⁾				25.2		
MCU SLEEP	NWP ACTIVE	TX	6 OFDM		325		mA
			54 OFDM		302		
	RX	54 OFDM		76			
	NWP idle connected ⁽³⁾				21.2		
MCU LPDS	NWP active	TX	6 OFDM		312		mA
			54 OFDM		289		
		RX	54 OFDM		63		
	NWP LPDS ⁽²⁾	SRAM Retention	64 KB		120		μA
			256 KB		135		
NWP idle connected ⁽³⁾				710			
MCU SHUTDOWN	MCU shutdown				1		μA
MCU HIBERNATE	MCU hibernate				5.5		μA
Peak calibration current ⁽⁵⁾		$V_{BAT} = 3.6\text{ V}$			290		mA
		$V_{BAT} = 3.3\text{ V}$			310		
		$V_{BAT} = 2.7\text{ V}$			310		
		$V_{BAT} = 2.3\text{ V}$			333		

- (1) Measurements taken at maximum TX power
- (2) LPDS current does not include the external serial flash. The CC3235MODS and CC3235MODAS can be configured to retain 0 KB, 64 KB, 128 KB, 192 KB, or 256 KB of SRAM in LPDS. Each 64-KB block of MCU retained SRAM increases LPDS current by 4 μA.
- (3) DTIM = 1
- (4) Typical numbers assume a VSWR of 1.5:1.
- (5) The complete calibration can take up to 17 mJ of energy from the battery over a period of 24 ms. Calibration is performed sparingly, typically when coming out of HIBERNATE and only if temperature has changed by more than 20°C. The calibration event can be controlled by a configuration file in the serial flash.

7.6 TX Power Control for 2.4 GHz Band

The CC3235MODS and CC3235MODAS has several options for modifying the output power of the device when required. For the 2.4 GHz band it is possible to lower the overall output power at a global level using the global TX power level setting. In addition, the 2.4 GHz band allows the user to enter additional back-offs ², per channel, region ³ and modulation rates ^{4 5}, through Image creator (see the [Uniflash with Image Creator User Guide](#) for more details).

Figure 7-1, Figure 7-2, and Figure 7-3 show TX power and IBAT versus TX power level settings for the CC3235MODS module at modulations of 1 DSSS, 6 OFDM, and 54 OFDM, respectively. For the CC3235MODSF module, the IBAT current has an increase of approximately 10 mA to 15 mA depending on the transmitted rate. The TX power level remains the same.⁴

In Figure 7-1, the area enclosed in the circle represents a significant reduction in current during transition from TX power level 3 to level 4. In the case of lower range requirements (14-dBm output power), TI recommends using TX power level 4 to reduce the current.

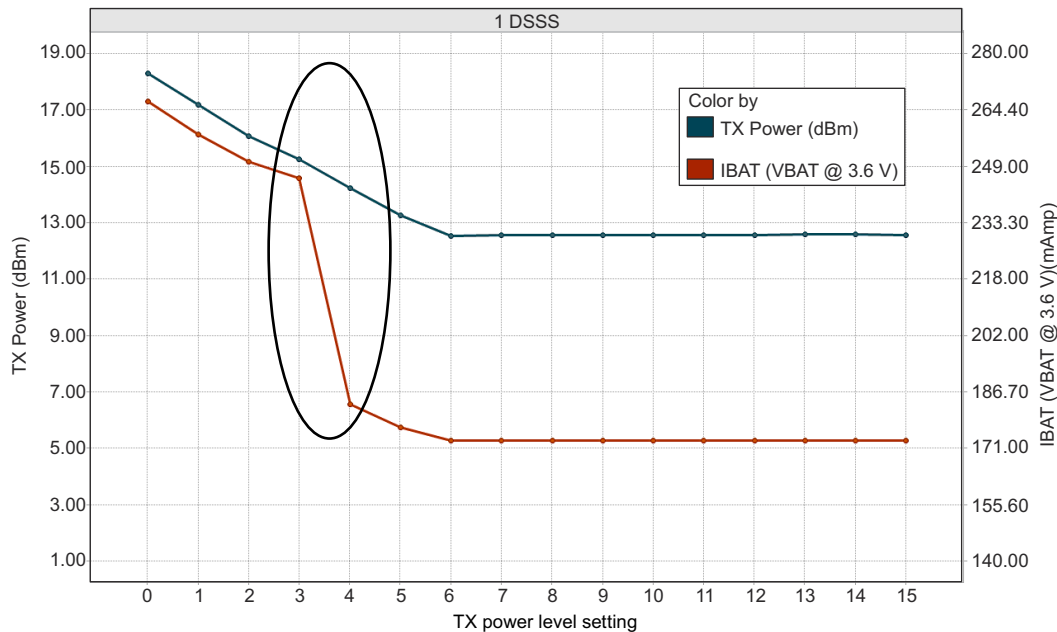

Figure 7-1. TX Power and IBAT vs TX Power Level Settings (1 DSSS)

² The back-off range is between –6 dB to +6 dB in 0.25-dB increments.

³ FCC, IC/ISED, ETSI/CE, MIC, and SRRC are supported.

⁴ Back-off rates are grouped into 11b rates, high modulation rates (MCS7, 54 OFDM and 48 OFDM), and lower modulation rates (all other rates).

⁵ There will be a difference between the CC3135MOD and CC3135 IC TX power levels.

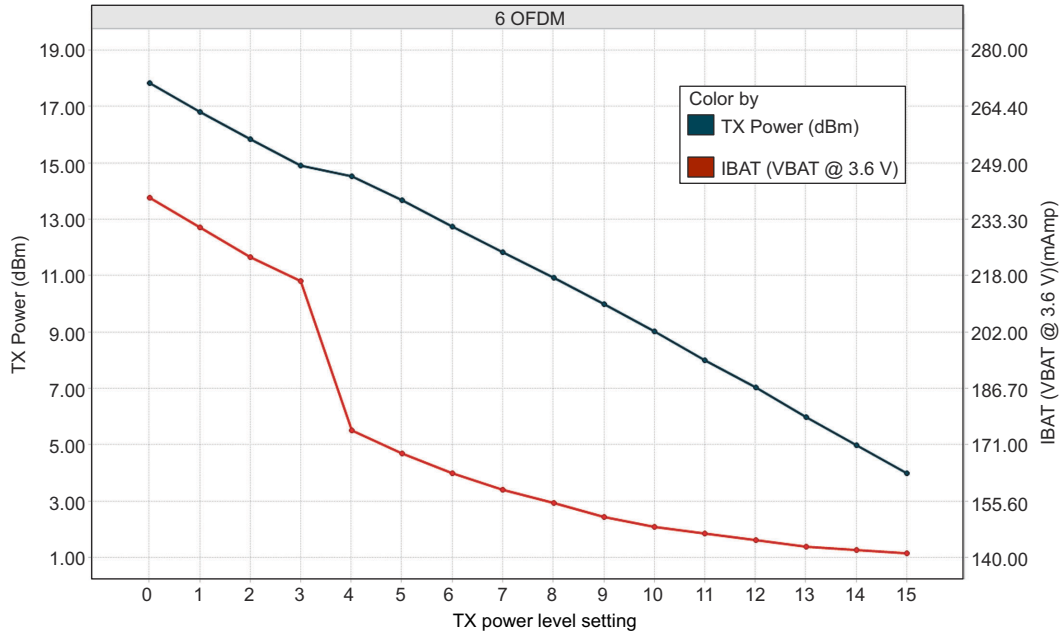

Figure 7-2. TX Power and IBAT vs TX Power Level Settings (6 OFDM)

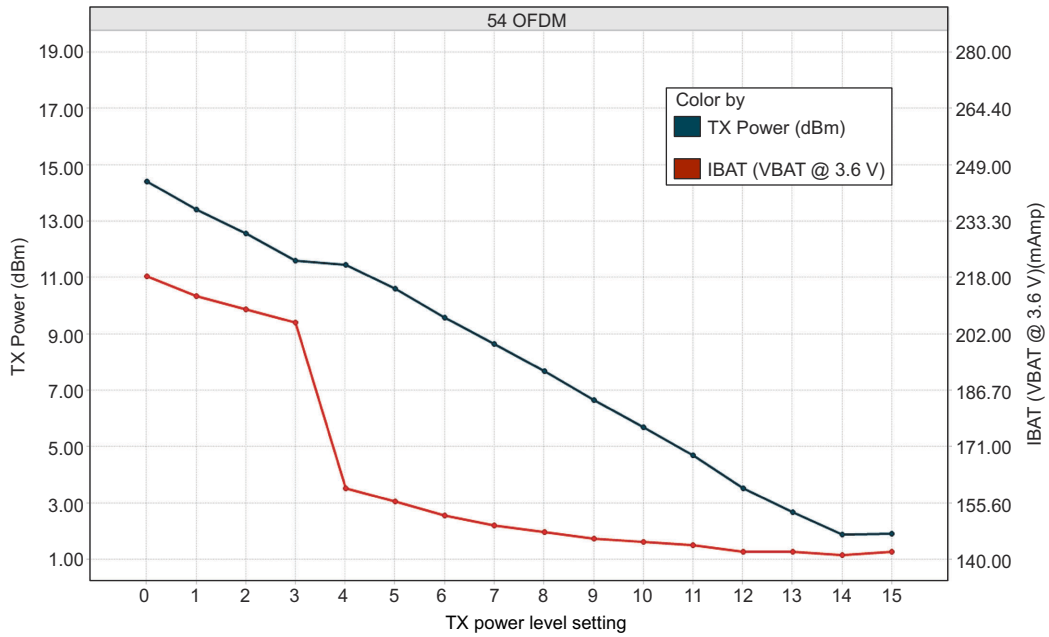

Figure 7-3. TX Power and IBAT vs TX Power Level Settings (54 OFDM)

7.7 TX Power Control for 5 GHz

5GHz power control is done via Image Creator where the maximum transmit power is provided ⁶. Within Image Creator, power control is possible per channel, region ⁷, and modulation rate ⁸. In addition, it is possible to enter an additional back-off ⁹ factor per channel and modulation rate for further margin to regulatory requirements.

It is also possible to set the TX and RX trace losses to the antenna per band ¹⁰. The peak antenna gain ¹¹ can also be provided, thus allowing further control. For a full description of options and capabilities see [Uniflash with Image Creator User Guide](#).

7.8 Brownout and Blackout Conditions

The module enters a brownout condition whenever the input voltage dips below V_{BROWNOUT} (see [Figure 7-4](#) and [Figure 7-5](#)). This condition must be considered during design of the power supply routing, especially if operating from a battery. High-current operations, such as a TX packet or any external activity (not necessarily related directly to networking) can cause a drop in the supply voltage, potentially triggering a brownout. The resistance includes the internal resistance of the battery, contact resistance of the battery holder (four contacts for a 2× AA battery), and the wiring and PCB routing resistance.

Note

When the module is in HIBERNATE state, brownout is not detected. Only blackout is in effect during HIBERNATE state.

⁶ The maximum transmit power range is 18 dBm to 0.125 dBm in 0.125-dBm decrements.

⁷ FCC, IC/ISED, ETSI/CE, MIC, and SRRC are supported.

⁸ Rates are grouped into high modulation rates (MCS7, 54 OFDM and 48 OFDM) and lower modulation rates (all other rates).

⁹ The back-off range is 0 dBm to 18 dBm in 0.125-dBm increments, with the maximum back-off not exceed that of the maximum transmit power.

¹⁰ The range of losses if from 0 dBm to 7.75 dBm in 0.125-dBm increments.

¹¹ The antenna gain has a range of -2 dBi to 5.75 dBi in 0.125-dBi increments.

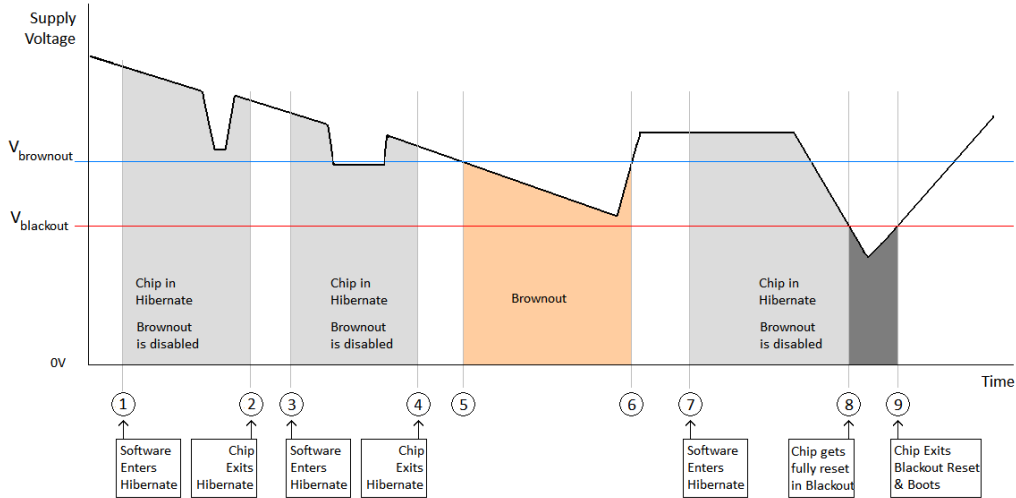

Figure 7-4. Brownout and Blackout Levels (1 of 2)

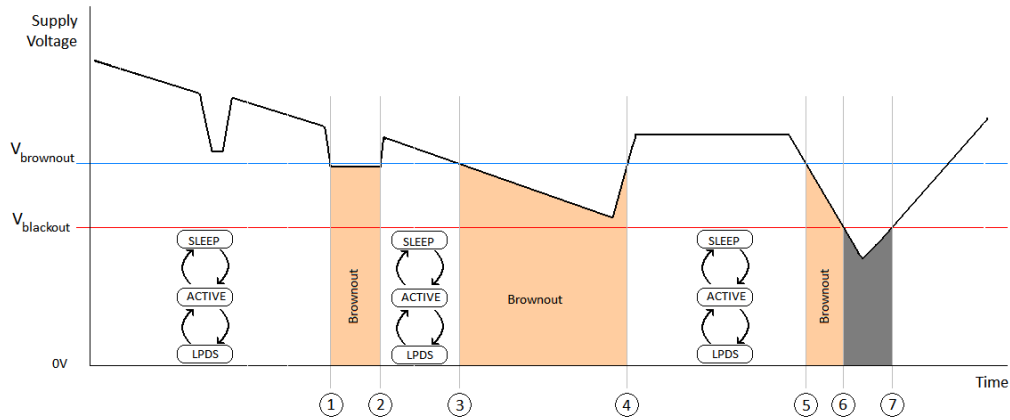

Figure 7-5. Brownout and Blackout Levels (2 of 2)

In the brownout condition, all sections of the device shut down within the module except for the Hibernate block (including the 32-kHz RTC clock), which remains on. The current in this state can reach approximately 400 μ A.

The blackout condition is equivalent to a hardware reset event in which all states within the module are lost.

$V_{\text{brownout}} = 2.1 \text{ V}$ and $V_{\text{blackout}} = 1.67 \text{ V}$

Table 7-5 lists the brownout and blackout voltage levels.

Table 7-5. Brownout and Blackout Voltage Levels

CONDITION	VOLTAGE LEVEL	UNIT
V_{brownout}	2.1	V
V_{blackout}	1.67	V

7.9 Electrical Characteristics for GPIO Pins

Table 7-6. GPIO Pins Except 25, 26, 42, and 44 (25°C) ⁽¹⁾

T_A = 25°C, V_{BAT} = 3.3 V

PARAMETER		TEST CONDITIONS	MIN	NOM	MAX	UNIT
C _{IN}	Pin capacitance			4		pF
V _{IH}	High-level input voltage		0.65 × V _{DD}		V _{DD} + 0.5 V	V
V _{IL}	Low-level input voltage		-0.5		0.35 × V _{DD}	V
I _{IH}	High-level input current			5		nA
I _{IL}	Low-level input current			5		nA
V _{OH}	High-level output voltage	IL = 2 mA; configured I/O drive strength = 2 mA; 2.4 V ≤ V _{DD} < 3.6 V			V _{DD} × 0.8	V
		IL = 4 mA; configured I/O drive strength = 4 mA; 2.4 V ≤ V _{DD} < 3.6 V			V _{DD} × 0.7	
		IL = 6 mA; configured I/O drive strength = 6 mA; 2.4 V ≤ V _{DD} < 3.6 V			V _{DD} × 0.7	
		IL = 2 mA; configured I/O drive strength = 2 mA; 2.3 V ≤ V _{DD} < 2.4 V			V _{DD} × 0.75	
V _{OL}	Low-level output voltage	IL = 2 mA; configured I/O drive strength = 2 mA; 2.4 V ≤ V _{DD} < 3.6 V	V _{DD} × 0.2			V
		IL = 4 mA; configured I/O drive strength = 4 mA; 2.4 V ≤ V _{DD} < 3.6 V	V _{DD} × 0.2			
		IL = 6 mA; configured I/O drive strength = 6 mA; 2.4 V ≤ V _{DD} < 3.6 V	V _{DD} × 0.2			
		IL = 2 mA; configured I/O drive strength = 2 mA; 2.3 V ≤ V _{DD} < 2.4 V	V _{DD} × 0.25			
I _{OH}	High-level source current,	2-mA drive		2		mA
		4-mA drive		4		
		6-mA drive		6		
I _{OL}	Low-level sink current,	2-mA drive		2		mA
		4-mA drive		4		
		6-mA drive		6		

- (1) TI recommends using the lowest possible drive strength that is adequate for the applications. This recommendation minimizes the risk of interference to the WLAN radio and reduces any potential degradation of RF sensitivity and performance. The default drive strength setting is 6 mA.

Table 7-7. GPIO Pins 25, 26, 42, and 44 (25°C) ⁽¹⁾

PARAMETER		TEST CONDITIONS	MIN	NOM	MAX	UNIT
C _{IN}	Pin capacitance			7		pF
V _{IH}	High-level input voltage		0.65 × V _{DD}		V _{DD} + 0.5 V	V
V _{IL}	Low-level input voltage		−0.5		0.35 × V _{DD}	V
I _{IH}	High-level input current			50		nA
I _{IL}	Low-level input current			50		nA
V _{OH}	High-level output voltage	IL = 2 mA; configured I/O drive strength = 2 mA; 2.4 V ≤ V _{DD} < 3.6 V			V _{DD} × 0.8	V
		IL = 4 mA; configured I/O drive strength = 4 mA; 2.4 V ≤ V _{DD} < 3.6 V			V _{DD} × 0.7	
		IL = 6 mA; configured I/O drive strength = 6 mA; 2.4 V ≤ V _{DD} < 3.6 V			V _{DD} × 0.7	
		IL = 2 mA; configured I/O drive strength = 2 mA; 2.3 V ≤ V _{DD} < 2.4 V			V _{DD} × 0.75	
V _{OL}	Low-level output voltage	IL = 2 mA; configured I/O drive strength = 2 mA; 2.4 V ≤ V _{DD} < 3.6 V	V _{DD} × 0.2			V
		IL = 4 mA; configured I/O drive strength = 4 mA; 2.4 V ≤ V _{DD} < 3.6 V	V _{DD} × 0.2			
		IL = 6 mA; configured I/O drive strength = 6 mA; 2.4 V ≤ V _{DD} < 3.6 V	V _{DD} × 0.2			
		IL = 2 mA; configured I/O drive strength = 2 mA; 2.3 V ≤ V _{DD} < 2.4 V	V _{DD} × 0.25			
I _{OH}	High-level source current, V _{OH} = 2.4	2-mA drive		1.5		mA
		4-mA drive		2.5		
		6-mA drive		3.5		
I _{OL}	Low-level sink current,	2-mA drive		1.5		mA
		4-mA drive		2.5		
		6-mA drive		3.5		
V _{IL}	nRESET			0.6		V

(1) TI recommends using the lowest possible drive strength that is adequate for the applications. This recommendation minimizes the risk of interference to the WLAN radio and reduces any potential degradation of RF sensitivity and performance. The default drive strength setting is 6 mA.

7.9.1 Electrical Characteristics for Pin Internal Pullup and Pulldown (25°C)

PARAMETER		TEST CONDITIONS	MIN	NOM	MAX	UNIT
I _{OH}	Pullup current (V _{DD} = 3.0 V)			10		μA
I _{OL}	Pulldown current (V _{DD} = 3.0 V)			10		μA

7.10 CC3235MODAx Antenna Characteristics

T_A = 25°C

PARAMETER	TEST CONDITIONS	MIN	TYP	MAX	UNIT	
Polarization		Linear				
Peak Gain	2.4 GHz Band				3.5	dBi
	5 GHz Band				4.5	dBi
Efficiency	2.4 GHz Band				70%	
	5 GHz Band				65%	

7.11 WLAN Receiver Characteristics

Table 7-8. WLAN Receiver Characteristics: 2.4 GHz Band

T_A = 25°C, V_{BAT} = 2.3 V to 3.6 V. Parameters are measured at the SoC pin on channel 6 (2437 MHz).

PARAMETER	TEST CONDITIONS (Mbps)	MIN	TYP	MAX	UNIT	
Sensitivity (8% PER for 11b rates, 10% PER for 11g/11n rates) ⁽¹⁾	1 DSSS				-94.5	dBm
	2 DSSS				-92.5	
	11 CCK				-86.5	
	6 OFDM				-89	
	9 OFDM				-88.5	
	18 OFDM				-85	
	36 OFDM				-79	
	54 OFDM				-73	
	MCS7 (GF) ⁽²⁾				-70	
Maximum input level (10% PER)	802.11b				-2.5	dBm
	802.11g				-8.5	

(1) Sensitivity is 1-dB worse on channel 13 (2472 MHz).

(2) Sensitivity for mixed mode is 1-dB worse.

Table 7-9. WLAN Receiver Characteristics: 5 GHz Band

T_A = 25°C, V_{BAT} = 2.3 V to 3.6 V.

PARAMETER	TEST CONDITIONS (Mbps)	MIN	TYP	MAX	UNIT	
Sensitivity (10% PER for 11g/11n rates)	6 OFDM				-89	dBm
	9 OFDM				-88	
	18 OFDM				-85	
	36 OFDM				-78.5	
	54 OFDM				-72	
	MCS7 (GF) ⁽¹⁾				-68	
Maximum input level	802.11a				-17	dBm

(1) Sensitivity for mixed mode is 1-dB worse.

7.12 WLAN Transmitter Characteristics

Table 7-10. WLAN Transmitter Characteristics: 2.4 GHz Band

$T_A = 25^\circ\text{C}$, $V_{BAT} = 2.3\text{ V to }3.6\text{ V}$.⁽¹⁾ Parameters measured at SoC pin on channel 6 (2437 MHz).^{(2) (3)}

PARAMETER	TEST CONDITIONS	MIN	TYP	MAX	UNIT
Operating frequency range ^{(4) (5)}		2412		2472	MHz
Maximum RMS output power measured at 1 dB from IEEE spectral mask or EVM	1 DSSS		16		dBm
	2 DSSS		16		
	11 CCK		16.3		
	6 OFDM		15.3		
	9 OFDM		15.3		
	18 OFDM		15		
	36 OFDM		14		
	54 OFDM		12.5		
	MCS7		11		
Transmit center frequency accuracy		-25		25	ppm

(1) Transmit power will be reduced by 1.5dB for $V_{BAT} < 2.8\text{V}$

(2) The 11g/n low rates on edge channels (2412 and 2462 MHz) have reduced TX power to meet FCC emission limits.

(3) Power of 802.11b rates are reduced to meet ETSI requirements in Europe.

(4) Channels 1 (2412 MHz) through 11 (2462 MHz) are supported for FCC.

(5) Channels 1 (2412 MHz) through 13 (2472MHz) are supported for Europe and Japan. Note that channel 14 is not supported for Japan.

Table 7-11. WLAN Transmitter Characteristics: 5GHz Band

$T_A = 25^\circ\text{C}$, $V_{BAT} = 2.3\text{ V to }3.6\text{V}$.⁽¹⁾ Parameters measured at SoC pin are the average of channels 40, 56, 120, and 157.^{(5) (6)}

PARAMETER	TEST CONDITIONS	MIN	TYP	MAX	UNIT
Operating frequency range ^{(2) (3) (4)}		5180		5825	MHz
Maximum RMS output power measured at 1 dB from IEEE spectral mask or EVM	6 OFDM		15.1		dBm
	9 OFDM		15.1		
	18 OFDM		15.1		
	36 OFDM		13.6		
	54 OFDM		12		
	MCS7		11		
Transmit center frequency accuracy		-20		20	ppm

(1) Transmit power will be reduced by 1.5dB for $V_{BAT} < 2.8\text{V}$

(2) FCC band covers U-NII-1, U-NII-2A, U-NII-2C, and U-NII-3 20MHz BW modulations.

(3) Europe bands 1, 2, and 3, 20MHz BW modulations are supported.

(4) For Japan, W52, W53 and W56, 20MHz BW modulations are supported.

(5) FCC channels 36, 60, 64, 100, and 140, where harmonics/subharmonics of fall in the FCC restricted band, have reduced output power to meet the FCC RSE requirement.

(6) The edge channels (100 and 140) have reduced TX power to meet FCC emissions limits.

7.13 BLE and WLAN Coexistence Requirements

For proper BLE and WLAN 2.4GHz radio coexistence, the following requirements must be met:

Table 7-12. BLE/WLAN Coex ⁽¹⁾ Isolation Requirement

PARAMETER	Band	MIN	TYP	MAX	UNIT
Port-to-port isolation	Dual antenna configuration ⁽²⁾	20 ⁽³⁾			dB

- (1) The CC3235MODS and CC3235MODAS modules are compatible with TI BLE modules using an external RF switch.
- (2) A single antenna configuration is possible using the CC3x35 devices.
- (3) For dual antenna configuration, the antenna placement must be such that isolation between the BLE and WLAN ports is at least 20dB.

7.14 Reset Requirement

PARAMETER	MIN	TYP	MAX	UNIT
V _{IH} Operation mode level		0.65 × V _{BAT}		V
V _{IL} Shutdown mode level ⁽¹⁾	0	0.6		V
Minimum time for nReset low for resetting the module	5			ms
T _r and T _f Rise and fall times		20		µs

- (1) The nRESET pin must be held below 0.6V for the module to register a reset.

7.15 Thermal Resistance Characteristics for MOB and MON Packages

NO.	PARAMETER	DESCRIPTION	°C/W ^{(1) (2)}	AIR FLOW (m/s) ⁽³⁾	
T1	R _{θJC}	Junction-to-case	11.4	N/A	
T2	R _{θJB}	Junction-to-board	8.0	N/A	
T3	R _{θJA}	Junction-to-free air	19.1	0	
T4			14.7	1	
T5			Junction-to-moving air	13.4	2
T6				12.5	3
T7	ψ _{JT}	Junction-to-free air	5.4	0	
T8			5.8	1	
T9			Junction-to-package top	6.1	2
T10				6.5	3
T11	ψ _{JB}	Junction-to-free air	6.8	0	
T12			6.6	1	
T13			Junction-to-board	6.6	2
T14				6.5	3

- (1) °C/W = degrees Celsius per watt.
- (2) These values are based on a JEDEC-defined 2S2P system (with the exception of the Theta JC [R_{θJC}] value, which is based on a JEDEC-defined 1S0P system) and will change based on the environment as well as application. For more information, see these EIA/JEDEC standards:
 - JESD51-2, *Integrated Circuits Thermal Test Method Environmental Conditions - Natural Convection (Still Air)*
 - JESD51-3, *Low Effective Thermal Conductivity Test Board for Leaded Surface Mount Packages*
 - JESD51-7, *High Effective Thermal Conductivity Test Board for Leaded Surface Mount Packages*
 - JESD51-9, *Test Boards for Area Array Surface Mount Package Thermal Measurements*
- (3) Power dissipation of 2W and an ambient temperature of 70°C is assumed.
- (3) m/s = meters per second.

7.16 Timing and Switching Characteristics

7.16.1 Power-Up Sequencing

For proper start-up of the CC3235MODx and CC3235MODAx module, perform the recommended power-up sequencing as follows:

1. Tie V_{BAT1} (pin 37) and V_{BAT2} (pin 40) together on the board.
2. Hold the nRESET pin low while the supplies are ramping up.

Figure 7-6 shows the reset timing diagram for the first-time power-up and reset removal.

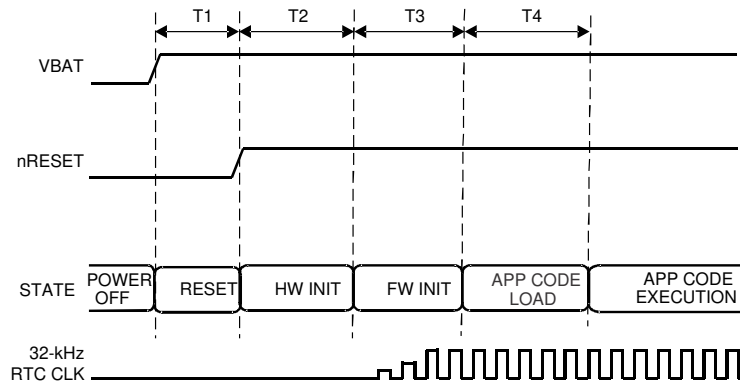

Figure 7-6. First-Time Power-Up and Reset Removal Timing Diagram

Table 7-13 lists the timing requirements for the first-time power-up and reset removal.

Table 7-13. First-Time Power-Up and Reset Removal Timing Requirements

ITEM	NAME	DESCRIPTION	MIN	TYP	MAX	UNIT
T1	nReset time	nReset timing after VBAT supplies are stable		1		ms
T2	Hardware wake-up time			25		ms
T3	Time taken by ROM firmware to initialize hardware	Includes internal 32kHz XOSC settling time		1.1		s
T4	App code load time for CC3235MODS and CC3235MODAS	CC3235MODS and CC3235MODAS		Image size (KB) × 1.7 ms		
	App code load time for CC3235MODSF and CC3235MODASF	CC3235MODSF and CC3235MODASF		Image size (KB) × 0.06 ms		

7.16.2 Power-Down Sequencing

For proper power down of the CC3235MODx and CC3235MODAx module, ensure that the nRESET (pin 35) and nHIB (pin 4) pins have remained in a known state for a minimum of 200ms before removing power from the module.

7.16.3 Device Reset

When a device restart is required, issue a negative pulse to the nRESET pin. Ensure the reset is properly applied: A negative reset pulse (on pin 35) of at least 200mS duration.

7.16.4 Wake Up From Hibernate Timing

Table 7-14 lists the software hibernate timing requirements.

Note

The internal 32.768kHz crystal is kept enabled by default when the module goes to hibernate.

Table 7-14. Software Hibernate Timing Requirements

ITEM	NAME	DESCRIPTION	MIN	TYP	MAX	UNIT
T _{HIB_MIN}	Minimum hibernate time		10			ms
T _{wake_from_hib} ⁽¹⁾	Hardware wakeup time plus firmware initialization time			50 ⁽²⁾		ms
T _{APP_CODE_LOAD}	App code load time for CC3235MODS and CC3235MODAS	CC3235MODS and CC3235MODAS	Image size (KB) × 1.7 ms			
	App code load time for CC3235MODSF and CC3235MODASF	CC3235MODSF and CC3235MODASF	Image size (KB) × 0.06 ms			

- (1) T_{wake_from_hib} can be 200ms on rare occasions when calibration is performed. Calibration is performed sparingly, typically when exiting Hibernate, and only if temperature has changed by more than 20°C or more than 24 hours have elapsed since a prior calibration.
- (2) Wake-up time can extend to 75ms if a patch is downloaded from the serial flash.

Figure 7-7 shows the timing diagram for wake up from the hibernate state.

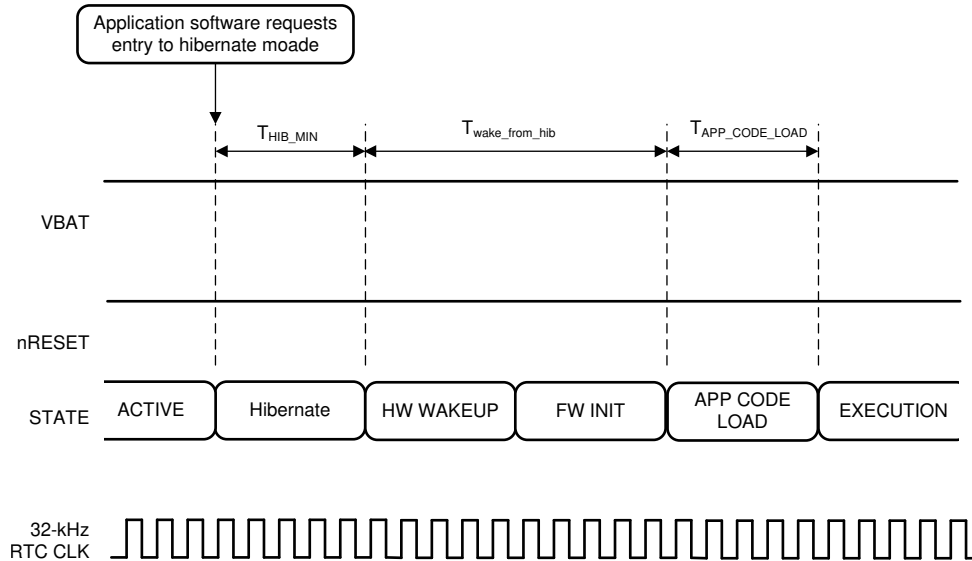

Figure 7-7. Wake Up From Hibernate Timing Diagram

7.16.5 Peripherals Timing

This section describes the peripherals that are supported by the CC3235MODx and CC3235MODAx module, as follows:

- SPI
- I2S
- GPIOs
- I²C
- IEEE 1149.1 JTAG
- ADC
- Camera parallel port
- External flash
- UART
- SD Host
- Timers

7.16.5.1 SPI

7.16.5.1.1 SPI Master

The CC3235MODx and CC3235MODAx MCU includes one SPI module, which can be configured as a master or slave device. The SPI includes a serial clock with programmable frequency, polarity, and phase; a programmable timing control between chip select and external clock generation; and a programmable delay before the first SPI word is transmitted. Slave mode does not include a dead cycle between two successive words.

Figure 7-8 shows the timing diagram for the SPI master.

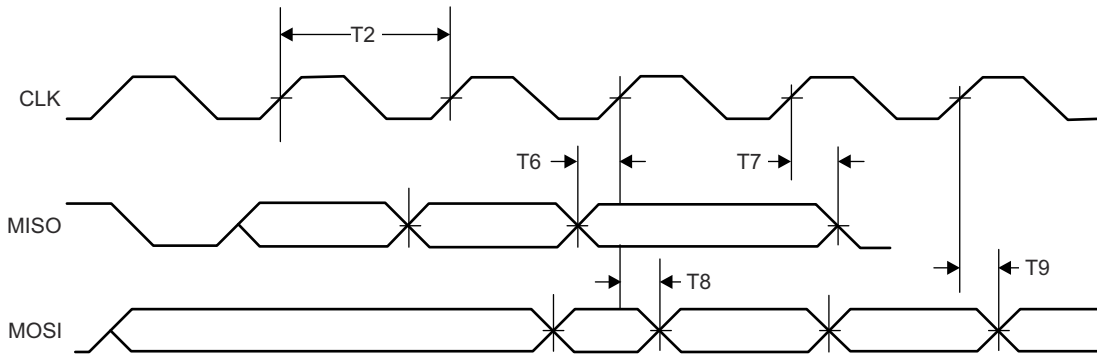

Figure 7-8. SPI Master Timing Diagram

Table 7-15 lists the timing parameters for the SPI master.

Table 7-15. SPI Master Timing Parameters

ITEM	NAME	DESCRIPTION	MIN	MAX	UNIT
	F ⁽¹⁾	Clock frequency		20	MHz
T2	T _{clk} ⁽¹⁾	Clock period	50		ns
	D ⁽¹⁾	Duty cycle	45%	55%	
T6	t _{IS} ⁽¹⁾	RX data setup time	1		ns
T7	t _{IH} ⁽¹⁾	RX data hold time	2		ns
T8	t _{OD} ⁽¹⁾	TX data output delay		8.5	ns
T9	t _{OH} ⁽¹⁾	TX data hold time		8	ns

(1) The timing parameter assumes a maximum load of 20pF.

7.16.5.1.2 SPI Slave

Figure 7-9 shows the timing diagram for the SPI slave.

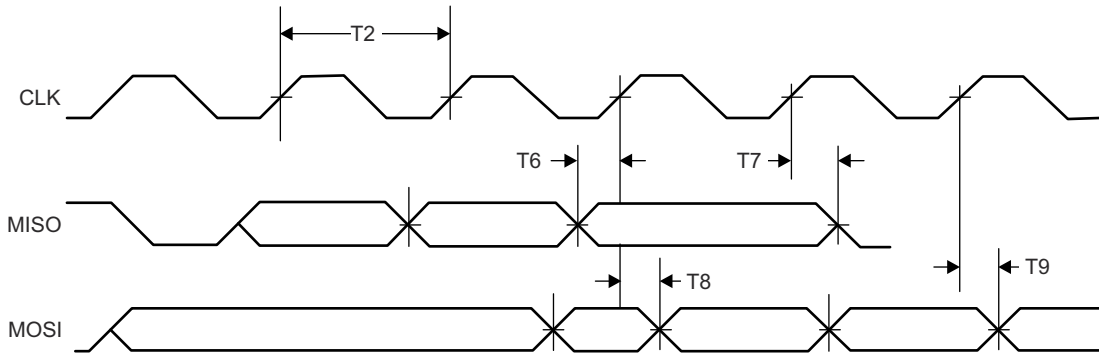

Figure 7-9. SPI Slave Timing Diagram

Table 7-16 lists the timing parameters for the SPI slave.

Table 7-16. SPI Slave Timing Parameters

ITEM	NAME	DESCRIPTION	MIN	MAX	UNIT
	F ⁽¹⁾	Clock frequency @ VBAT = 3.3V		20	MHz
		Clock frequency @ VBAT ≤ 2.3V		12	
T2	T _{clk} ⁽¹⁾	Clock period	50		ns
	D ⁽¹⁾	Duty cycle	45%	55%	
T6	t _{IS} ⁽¹⁾	RX data setup time	4		ns
T7	t _{IH} ⁽¹⁾	RX data hold time	4		ns
T8	t _{OD} ⁽¹⁾	TX data output delay		20	ns
T9	t _{OH} ⁽¹⁾	TX data hold time		24	ns

(1) The timing parameter assumes a maximum load of 20pF at 3.3V.

7.16.5.2 I2S

The McASP interface functions as a general-purpose audio serial port optimized for multichannel audio applications and supports transfer of two stereo channels over two data pins. The McASP consists of transmit and receive sections that operate synchronously and have programmable clock and frame-sync polarity. A fractional divider is available for bit-clock generation.

7.16.5.2.1 I2S Transmit Mode

Figure 7-10 shows the timing diagram for the I2S transmit mode.

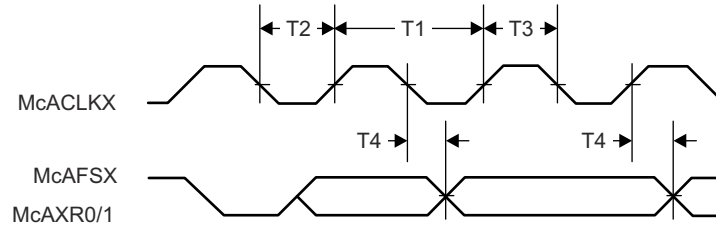

Figure 7-10. I2S Transmit Mode Timing Diagram

Table 7-17 lists the timing parameters for the I2S transmit mode.

Table 7-17. I2S Transmit Mode Timing Parameters

ITEM	NAME	DESCRIPTION	MIN	MAX	UNIT
T1	$f_{clk}^{(1)}$	Clock frequency		9.216	MHz
T2	$t_{LP}^{(1)}$	Clock low period		1/2 fclk	ns
T3	$t_{HT}^{(1)}$	Clock high period		1/2 fclk	ns
T4	$t_{OH}^{(1)}$	TX data hold time		22	ns

(1) The timing parameter assumes a maximum load of 20pF.

7.16.5.2.2 I2S Receive Mode

Figure 7-11 shows the timing diagram for the I2S receive mode.

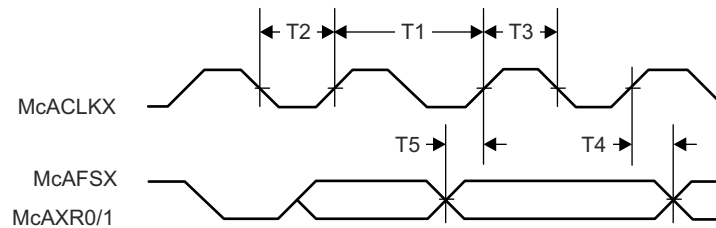

Figure 7-11. I2S Receive Mode Timing Diagram

Table 7-18 lists the timing parameters for the I2S receive mode.

Table 7-18. I2S Receive Mode Timing Parameters

ITEM	NAME	DESCRIPTION	MIN	MAX	UNIT
T1	$f_{clk}^{(1)}$	Clock frequency		9.216	MHz
T2	$t_{LP}^{(1)}$	Clock low period		1/2 f_{clk}	ns
T3	$t_{HT}^{(1)}$	Clock high period		1/2 f_{clk}	ns
T4	$t_{OH}^{(1)}$	RX data hold time		0	ns
T5	$t_{OS}^{(1)}$	RX data setup time		15	ns

(1) Timing parameter assumes a maximum load of 20pF.

7.16.5.3 GPIOs

All digital pins of the module can be used as general-purpose input/output (GPIO) pins. The GPIO module consists of four GPIO blocks, each of which provides eight GPIOs. The GPIO module supports 24 programmable GPIO pins, depending on the peripheral used. Each GPIO has configurable pullup and pulldown strength (weak 10µA), configurable drive strength (2, 4, and 6mA), and open-drain enable.

Figure 7-12 shows the GPIO timing diagram.

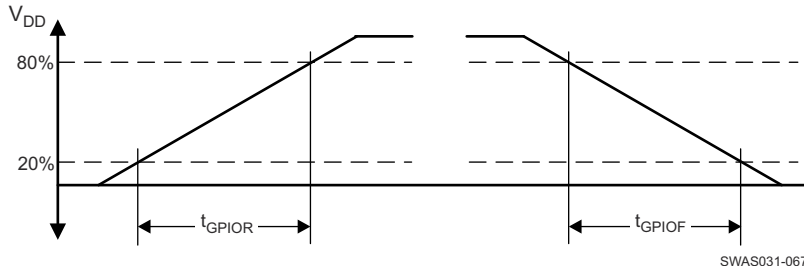

Figure 7-12. GPIO Timing Diagram

Table 7-19 lists the GPIO output transition times for $V_{BAT} = 2.3V$.

Table 7-19. GPIO Output Transition Times ($V_{BAT} = 2.3 V$) ^{(1) (2)}

DRIVE STRENGTH (mA)	DRIVE STRENGTH CONTROL BITS	T_r			T_f			UNIT
		MIN	NOM	MAX	MIN	NOM	MAX	
2	2MA_EN=1	11.7	13.9	16.3	11.5	13.9	16.7	ns
	4MA_EN=0							
4	2MA_EN=0	13.7	15.6	18.0	9.9	11.6	13.6	ns
	4MA_EN=1							
6	2MA_EN=1	5.5	6.4	7.4	3.8	4.7	5.8	ns
	4MA_EN=1							

(1) $V_{BAT} = 2.3V$, $T = 25^\circ C$, total pin load = 30pF

(2) The transition data applies to the pins other than the multiplexed analog-digital pins 25, 26, 42, and 44.

Table 7-20 lists the GPIO output transition times for $V_{BAT} = 3.3V$.

Table 7-20. GPIO Output Transition Times ($V_{BAT} = 3.3V$) ^{(1) (2)}

DRIVE STRENGTH (mA)	DRIVE STRENGTH CONTROL BITS	T_r			T_f			UNIT
		MIN	NOM	MAX	MIN	NOM	MAX	
2	2MA_EN=1	8.0	9.3	10.7	8.2	9.5	11.0	ns
	4MA_EN=0							
4	2MA_EN=0	6.6	7.1	7.6	4.7	5.2	5.8	ns
	4MA_EN=1							
6	2MA_EN=1	3.2	3.5	3.7	2.3	2.6	2.9	ns
	4MA_EN=1							

(1) $V_{BAT} = 3.3V$, $T = 25^\circ C$, total pin load = 30pF

(2) The transition data applies to the pins except the multiplexed analog-digital pins 29, 30, 45, 50, 52 and 53.

7.16.5.3.1 GPIO Input Transition Time Parameters

Table 7-21 lists the input transition time parameters.

Table 7-21. GPIO Input Transition Time Parameters

		MIN	MAX	UNIT
t_r	Input transition time (t_r , t_f), 10% to 90%	1	3	ns
t_f		1	3	ns

7.16.5.4 I²C

The CC3235MODx and CC3235MODAx MCU includes one I²C module operating with standard (100kbps) or fast (400kbps) transmission speeds.

Figure 7-13 shows the I²C timing diagram.

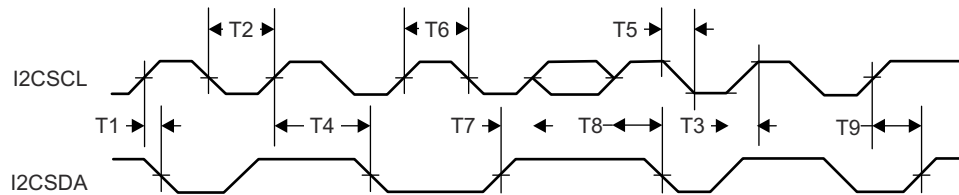

Figure 7-13. I²C Timing Diagram

Table 7-22 lists the I²C timing parameters.

Table 7-22. I²C Timing Parameters ⁽³⁾

ITEM	NAME	DESCRIPTION	MIN	MAX	UNIT
T2	t_{LP}	Clock low period	See ⁽¹⁾		System clock
T3	t_{SRT}	SCL/SDA rise time		See ⁽²⁾	ns
T4	t_{DH}	Data hold time	NA		
T5	t_{SFT}	SCL/SDA fall time	3		ns
T6	t_{HT}	Clock high time	See ⁽¹⁾		System clock
T7	t_{DS}	Data setup time	$t_{LP}/2$		System clock
T8	t_{SCSR}	Start condition setup time	36		System clock
T9	t_{SCS}	Stop condition setup time	24		System clock

- (1) This value depends on the value programmed in the clock period register of I²C. Maximum output frequency is the result of the minimal value programmed in this register.
- (2) Because I²C is an open-drain interface, the controller can drive logic 0 only. Logic 1 is the result of external pullup. Rise time depends on the value of the external signal capacitance and external pullup register.
- (3) All timing is with a 6mA drive and 20pF load.

7.16.5.5 IEEE 1149.1 JTAG

The Joint Test Action Group (JTAG) port is an IEEE standard that defines a test access port (TAP) and boundary scan architecture for digital integrated circuits and provides a standardized serial interface to control the associated test logic. For detailed information on the operation of the JTAG port and TAP controller, see the IEEE Standard 1149.1, *Test Access Port and Boundary-Scan Architecture*.

Figure 7-14 shows the JTAG timing diagram.

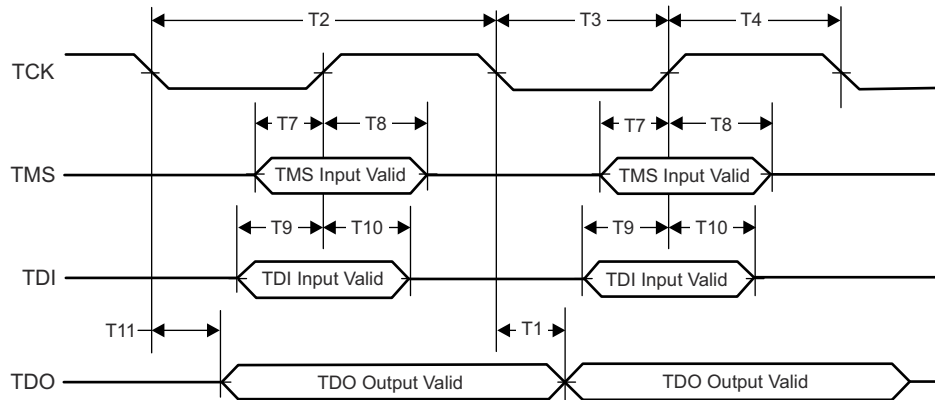

Figure 7-14. JTAG Timing Diagram

Table 7-23 lists the JTAG timing parameters.

Table 7-23. JTAG Timing Parameters

ITEM	NAME	DESCRIPTION	MIN	MAX	UNIT
T1	f_{TCK}	Clock frequency		15	MHz
T2	t_{TCK}	Clock period		$1 / f_{TCK}$	ns
T3	t_{CL}	Clock low period		$t_{TCK} / 2$	ns
T4	t_{CH}	Clock high period		$t_{TCK} / 2$	ns
T7	t_{TMS_SU}	TMS setup time	1		ns
T8	t_{TMS_HO}	TMS hold time	16		ns
T9	t_{TDI_SU}	TDI setup time	1		ns
T10	t_{TDI_HO}	TDI hold time	16		ns
T11	t_{TDO_HO}	TDO hold time		15	ns

7.16.5.6 ADC

Table 7-24 lists the ADC electrical specifications. See [CC32xx ADC Appnote](#) for further information on using the ADC and for application-specific examples.

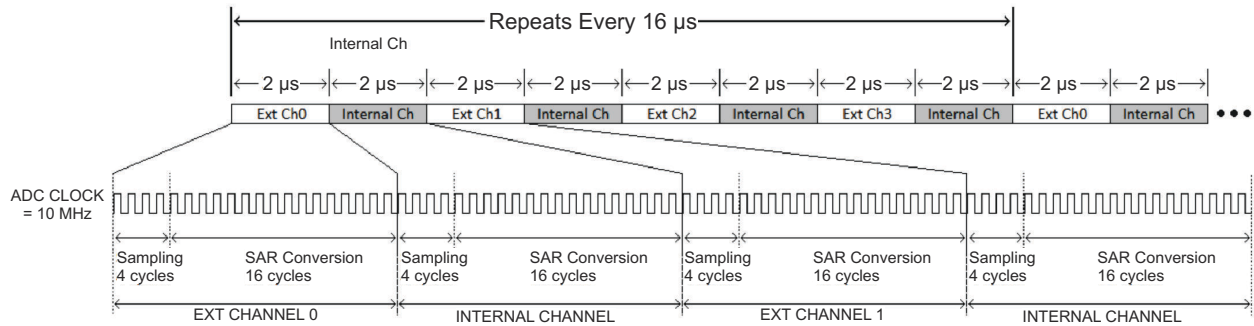

Figure 7-15. ADC Clock Timing Diagram

Figure 7-15 shows the ADC clock timing diagram.

Table 7-24. ADC Electrical Specifications

PARAMETER	DESCRIPTION	TEST CONDITIONS / ASSUMPTIONS	MIN	TYP	MAX	UNIT
Nbits	Number of bits			12		Bits
INL	Integral nonlinearity	Worst-case deviation from histogram method over full scale (not including first and last three LSB levels)	-2.5		2.5	LSB
DNL	Differential nonlinearity	Worst-case deviation of any step from ideal	-1		4	LSB
Input range			0		1.4	V
Driving source impedance					100	Ω
FCLK	Clock rate	Successive approximation input clock rate		10		MHz
Input capacitance				12		pF
Input impedance		ADC Pin 57		2.15		k Ω
		ADC Pin 58		0.7		
		ADC Pin 59		2.12		
		ADC Pin 60		1.17		
Number of channels			4			
F _{sample}	Sampling rate of each pin			62.5		KSPS
F _{input_max}	Maximum input signal frequency				31	kHz
SINAD	Signal-to-noise and distortion	Input frequency DC to 300 Hz and 1.4 V _{pp} sine wave input	55	60		dB
I _{active}	Active supply current	Average for analog-to-digital during conversion without reference current		1.5		mA
I _{PD}	Power-down supply current for core supply	Total for analog-to-digital when not active (this must be the SoC level test)		1		μ A
Absolute offset error		FCLK = 10 MHz		\pm 2		mV
Gain error				\pm 2%		

Table 7-24. ADC Electrical Specifications (continued)

PARAMETER	DESCRIPTION	TEST CONDITIONS / ASSUMPTIONS	MIN	TYP	MAX	UNIT
V _{ref}	ADC reference voltage			1.467		V

7.16.5.7 Camera Parallel Port

The fast camera parallel port interfaces with a variety of external image sensors, stores the image data in a FIFO, and generates DMA requests. The camera parallel port supports 8 bits.

Figure 7-16 shows the timing diagram for the camera parallel port.

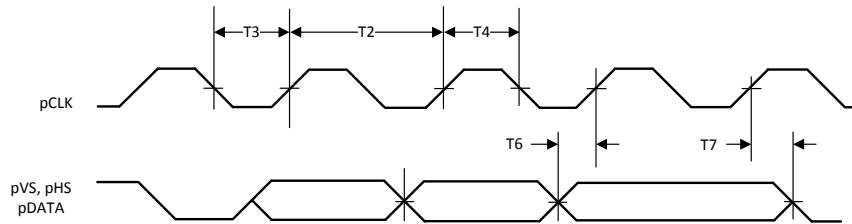

Figure 7-16. Camera Parallel Port Timing Diagram

Table 7-25 lists the timing parameters for the camera parallel port.

Table 7-25. Camera Parallel Port Timing Parameters

ITEM	NAME	DESCRIPTION	MIN	MAX	UNIT
	pCLK	Clock frequency		2	MHz
T2	T _{clk}	Clock period		1/pCLK	ns
T3	t _{LP}	Clock low period		T _{clk} /2	ns
T4	t _{HT}	Clock high period		T _{clk} /2	ns
T6	t _{IS}	RX data setup time		2	ns
T7	t _{IH}	RX data hold time		2	ns

7.16.5.8 UART

The CC3235MODx and CC3235MODAx MCU includes two UARTs with the following features:

- Programmable baud-rate generator allowing speeds up to 3Mbps
- Separate 16-bit × 8-bit TX and RX FIFOs to reduce CPU interrupt service loading
- Programmable FIFO length, including a 1-byte-deep operation providing a conventional double-buffered interface
- FIFO trigger levels of 1/8, 1/4, 1/2, 3/4, and 7/8
- Standard asynchronous communication bits for start, stop, and parity
- Generation and detection of line-breaks
- Fully programmable serial interface characteristics:
 - 5, 6, 7, or 8 data bits
 - Generation and detection of even, odd, stick, or no-parity bits
 - Generation of 1 or 2 stop-bits
- RTS and CTS hardware flow support
- Standard FIFO-level and end-of-transmission interrupts
- Efficient transfers using μ DMA:
 - Separate channels for transmit and receive
 - Receive single request asserted when data is in the FIFO; burst request asserted at programmed FIFO level
 - Transmit single request asserted when there is space in the FIFO; burst request asserted at programmed FIFO level
- The system clock is used to generate the baud clock.

7.16.5.9 External Flash Interface

The CC3235MODx and CC3235MODAx MCU includes the Macronix™ 32-Mbit serial flash. The serial flash can be programmed directly using the external flash interface (pins 13, 14, 15, and 17). During normal operation, the external flash interface should remain unconnected.

For timing details, see the [MX25R3235F](#) data sheet.

7.16.5.10 SD Host

The CC3235MODx and CC3235MODAx MCU provides an interface between a local host (LH), such as an MCU and an SD memory card, and handles SD transactions with minimal LH intervention.

The SD host does the following:

- Provides SD card access in 1-bit mode
- Deals with SD protocol at the transmission level
- Handles data packing
- Adds cyclic redundancy checks (CRC)
- Start and end bit
- Checks for syntactical correctness

The application interface sends every SD command and either polls for the status of the adapter or waits for an interrupt request. The result is then sent back to the application interface in case of exceptions or to warn of end-of-operation. The controller can be configured to generate DMA requests and work with minimum CPU intervention. Given the nature of the integration of this peripheral on the CC3235x platform, TI recommends that developers use peripheral library APIs to control and operate the block. This section emphasizes understanding the SD host APIs provided in the peripheral library of the [CC3235x Software Development Kit \(SDK\)](#).

The SD host features are as follows:

- Full compliance with SD command and response sets, as defined in the SD memory card
 - Specifications, v2.0
 - Includes high-capacity (size >2 GB) cards HC SD
- Flexible architecture, allowing support for new command structure.
- 1-bit transfer mode specifications for SD cards
- Built-in 1024-byte buffer for read or write
 - 512-byte buffer for both transmit and receive
 - Each buffer is 32-bits wide by 128-words deep
- 32-bit-wide access bus to maximize bus throughput
- Single interrupt line for multiple interrupt source events
- Two slave DMA channels (1 for TX, 1 for RX)
- Programmable clock generation
- Integrates an internal transceiver that allows a direct connection to the SD card without an external transceiver
- Supports configurable busy and response timeout
- Support for a wide range of card clock frequency with odd and even clock ratio
- Maximum frequency supported is 24MHz

7.16.5.11 Timers

Programmable timers can be used to count or time external events that drive the timer input pins. The general-purpose timer module (GPTM) of the CC3235MODx and CC3235MODAx MCU contains 16- or 32-bit GPTM blocks. Each 16- or 32-bit GPTM block provides two 16-bit timers or counters (referred to as Timer A and Timer B) that can be configured to operate independently as timers or event counters, or they can be concatenated to operate as one 32-bit timer. Timers can also be used to trigger μ DMA transfers.

The GPTM contains four 16- or 32-bit GPTM blocks with the following functional options:

- Operating modes:
 - 16- or 32-bit programmable one-shot timer
 - 16- or 32-bit programmable periodic timer
 - 16-bit general-purpose timer with an 8-bit prescaler
 - 16-bit input-edge count- or time-capture modes with an 8-bit prescaler
 - 16-bit PWM mode with an 8-bit prescaler and software-programmable output inversion of the PWM signal
- Counts up or counts down
- Sixteen 16- or 32-bit capture compare pins (CCP)
- User-enabled stalling when the microcontroller asserts CPU Halt flag during debug
- Ability to determine the elapsed time between the assertion of the timer interrupt and entry into the interrupt service routine
- Efficient transfers using micro direct memory access controller (μ DMA):
 - Dedicated channel for each timer
 - Burst request generated on timer interrupt
- Runs from system clock (80MHz)

8 Detailed Description

8.1 Overview

The CC3235MODx and CC3235MODAx MCU is a Dual-Band Wi-Fi internet-on-a chip module that consists of an Arm Cortex-M4 processor with a rich set of peripherals for diverse application requirements, a Wi-Fi network processor, and power-management subsystems.

8.2 Functional Block Diagram

Figure 8-1 shows the functional block diagram of the CC3235MODx and CC3235MODAx SimpleLink™ Wi-Fi® solution.

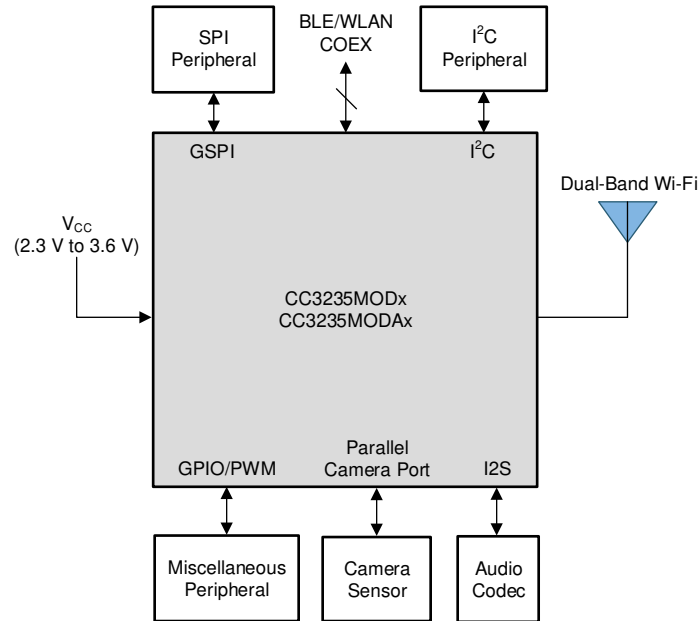

Figure 8-1. Functional Block Diagram

8.3 Arm Cortex-M4 Processor Core Subsystem

The high-performance Arm Cortex-M4 processor provides a low-cost platform that meets the needs of minimal memory implementation, reduced pin count, and low power consumption, while delivering outstanding computational performance and exceptional system response to interrupts.

- The Cortex-M4 core has low-latency interrupt processing with the following features:
 - A 32-bit Arm Thumb® instruction set optimized for embedded applications
 - Handler and thread modes
 - Low-latency interrupt handling by automatic processor state saving and restoration during entry and exit
 - Support for ARMv6 unaligned accesses
- Nested vectored interrupt controller (NVIC) closely integrated with the processor core to achieve low-latency interrupt processing. The NVIC includes the following features:
 - Bits of priority configurable from 3 to 8
 - Dynamic reprioritization of interrupts
 - Priority grouping that enables selection of preempting interrupt levels and nonpreempting interrupt levels
 - Support for tail-chaining and late arrival of interrupts, which enables back-to-back interrupt processing without the overhead of state saving and restoration between interrupts
 - Processor state automatically saved on interrupt entry and restored on interrupt exit with no instruction overhead
 - Wake-up interrupt controller (WIC) providing ultra-low-power sleep mode support
- Bus interfaces:
 - Advanced high-performance bus (AHB-Lite) interfaces: system bus interfaces
 - Bit-band support for memory and select peripheral that includes atomic bit-band write and read operations
- Low-cost debug solution featuring:
 - Debug access to all memory and registers in the system, including access to memory-mapped devices, access to internal core registers when the core is halted, and access to debug control registers even while SYSRESETn is asserted
 - Serial wire debug port (SW-DP) or serial wire JTAG debug port (SWJ-DP) debug access
 - Flash patch and breakpoint (FPB) unit to implement breakpoints and code patches

8.4 Wi-Fi Network Processor Subsystem

The Wi-Fi network processor subsystem includes a dedicated Arm MCU to completely offload the host MCU along with an 802.11 a/b/g/n radio, baseband, and MAC with a powerful crypto engine for a fast, secure WLAN and Internet connections with 256-bit encryption. The CC3235MODx and CC3235MODAx MCU supports station, AP, and Wi-Fi Direct modes. The module also supports WPA2 personal and enterprise security, WPS 2.0, and WPA3 personal and enterprise ¹². The Wi-Fi network processor includes an embedded IPv6, IPv4 TCP/IP stack, TLS stack, and network applications such as HTTPS server.

8.4.1 WLAN

The WLAN features are as follows:

- 802.11 a/b/g/n integrated radio, modem, and MAC supporting WLAN communication as a BSS station, AP, Wi-Fi Direct client and group owner with CCK and OFDM rates in the 2.4GHz ISM band, channels 1 to 13, and 5GHz U-NII band.

Note

802.11n is supported only in Wi-Fi station, Wi-Fi Direct, and P2P client modes.

- Autocalibrated radio with a single-ended 50Ω interface enables easy connection to the antenna without requiring expertise in radio circuit design.
- Advanced connection manager with multiple user-configurable profiles stored in serial-flash allows automatic fast connection to an access point without user or host intervention.
- Supports all common Wi-Fi security modes for personal and enterprise networks with on-chip security accelerators, including: WEP, WPA/WPA2 PSK, WPA2 Enterprise (802.1x), WPA3 Personal, and WPA3 Enterprise.

Note

When using WPA Enterprise security modes, the TLS socket used to communicate with the Radius server is limited to TLSv1.0.

- Smart provisioning options deeply integrated within the module providing a comprehensive end-to-end solution. With elaborate events notification to the host, enabling the application to control the provisioning decision flow. The wide variety of Wi-Fi provisioning methods include:
 - Access Point using HTTPS
 - SmartConfig Technology: a 1-step, 1-time process to connect a CC3235MODx or CC3235MODAx-enabled module to the home wireless network, removing dependency on the I/O capabilities of the host MCU; thus, it is usable by deeply embedded applications
- 802.11 transceiver mode allows transmitting and receiving of proprietary data through a socket without adding MAC or PHY headers. The 802.11 transceiver mode provides the option to select the working channel, rate, and transmitted power. The receiver mode works with the filtering options.

8.4.2 Network Stack

The Network Stack features are as follows:

- Integrated IPv4, IPv6 TCP/IP stack with BSD socket APIs for simple Internet connectivity with any MCU, microprocessor, or ASIC

Note

Not all APIs are 100% BSD compliant. Not all BSD APIs are supported.

- Support of 16 simultaneous TCP, UDP, RAW, SSL/TLS sockets
- Built-in network protocols:
 - Static IP, LLA, DHCPv4, DHCPv6 with DAD and stateless autoconfiguration
 - ARP, ICMPv4, IGMP, ICMPv6, MLD, ND

¹² See CC3x35 SDK v3.40 or newer for details. Limited to STA mode only.

- DNS client for easy connection to the local network and the Internet
- Built-in network application and utilities:
 - HTTP/HTTPS
 - Web page content stored on serial flash
 - RESTful APIs for setting and configuring application content
 - Dynamic user callbacks
 - Service discovery: Multicast DNS service discovery lets a client advertise its service without a centralized server. After connecting to the access point, the CC3235MODx or CC3235MODAx MCU provides critical information, such as device name, IP, vendor, and port number.
 - DHCP server
 - Ping

Table 8-1 describes the NWP features.

Table 8-1. NWP Features

Feature	Description
Wi-Fi standards	802.11a/b/g/n station 802.11a/b/g AP supporting up to four stations Wi-Fi Direct client and group owner
Wi-Fi channels	2.4 GHz ISM and 5 GHz U-NII Channels
Channel Bandwidth	20 MHz
Wi-Fi security	WEP, WPA/WPA2 PSK, WPA2 enterprise (802.1x), WPA3 personal and enterprise ⁽¹⁾
Wi-Fi provisioning	SmartConfig technology, Wi-Fi protected setup (WPS2), AP mode with internal HTTP web server
IP protocols	IPv4/IPv6
IP addressing	Static IP, LLA, DHCPv4, DHCPv6 with DAD
Cross layer	ARP, ICMPv4, IGMP, ICMPv6, MLD, NDP
Transport	UDP, TCP SSLv3.0/TLSv1.0/TLSv1.1/TLSv1.2 RAW
Network applications and utilities	Ping HTTP/HTTPS web server mDNS DNS-SD DHCP server
Host interface	UART/SPI
Security	Device identity Trusted root-certificate catalog TI root-of-trust public key The CC3235S and CC3235SF variants also support: <ul style="list-style-type: none"> • Secure key storage • Online certificate status protocol (OCSP) • Certificate signing request (CSR) • Unique per device Key-Pair • File system security • Software tamper detection • Cloning protection • Secure boot • Validate the integrity and authenticity of the run-time binary during boot • Initial secure programming • Debug security • JTAG and debug

Table 8-1. NWP Features (continued)

Feature	Description
Power management	Enhanced power policy management uses 802.11 power save and deep-sleep power modes
Other	Transceiver Programmable RX filters with event-trigger mechanism Rx Metrics for tracking the surrounding RF environment

(1) See CC3x35 SDK v3.40 or newer for details. Limited to STA mode only. When using WPA Enterprise security modes, the TLS socket used to communicate with the Radius server is limited to TLSv1.0.

8.5 Security

The SimpleLink Wi-Fi CC3235MODx and CC3235MODAx internet-on-a-chip module enhances the security capabilities available for development of IoT devices, while completely offloading these activities from the MCU to the networking subsystem. The security capabilities include the following key features:

Wi-Fi and Internet Security:

- Personal and enterprise Wi-Fi security
 - Personal standards
 - AES (WPA2-PSK)
 - TKIP (WPA-PSK)
 - WEP
 - Enterprise standards
 - EAP Fast
 - EAP PEAPv0/1
 - EAP PEAPv0 TLS
 - EAP PEAPv1 TLS EAP LS
 - EAP TLS
 - EAP TTLS TLS
 - EAP TTLS MSCHAPv2
- Secure sockets
 - Protocol versions: SSL v3, TLS 1.0, TLS 1.1, TLS 1.2
 - Powerful crypto engine for fast, secure Wi-Fi and internet connections with 256-bit AES encryption for TLS and SSL connections
 - Ciphers suites
 - SL_SEC_MASK_SSL_RSA_WITH_RC4_128_SHA
 - SL_SEC_MASK_SSL_RSA_WITH_RC4_128_MD5
 - SL_SEC_MASK_TLS_RSA_WITH_AES_256_CBC_SHA
 - SL_SEC_MASK_TLS_DHE_RSA_WITH_AES_256_CBC_SHA
 - SL_SEC_MASK_TLS_ECDHE_RSA_WITH_AES_256_CBC_SHA
 - SL_SEC_MASK_TLS_ECDHE_RSA_WITH_RC4_128_SHA
 - SL_SEC_MASK_TLS_RSA_WITH_AES_128_CBC_SHA256
 - SL_SEC_MASK_TLS_RSA_WITH_AES_256_CBC_SHA256
 - SL_SEC_MASK_TLS_ECDHE_RSA_WITH_AES_128_CBC_SHA256
 - SL_SEC_MASK_TLS_ECDHE_ECDSA_WITH_AES_128_CBC_SHA256
 - SL_SEC_MASK_TLS_ECDHE_ECDSA_WITH_AES_128_CBC_SHA
 - SL_SEC_MASK_TLS_ECDHE_ECDSA_WITH_AES_256_CBC_SHA
 - SL_SEC_MASK_TLS_RSA_WITH_AES_128_GCM_SHA256
 - SL_SEC_MASK_TLS_RSA_WITH_AES_256_GCM_SHA384
 - SL_SEC_MASK_TLS_DHE_RSA_WITH_AES_128_GCM_SHA256
 - SL_SEC_MASK_TLS_DHE_RSA_WITH_AES_256_GCM_SHA384
 - SL_SEC_MASK_TLS_ECDHE_RSA_WITH_AES_128_GCM_SHA256
 - SL_SEC_MASK_TLS_ECDHE_RSA_WITH_AES_256_GCM_SHA384
 - SL_SEC_MASK_TLS_ECDHE_ECDSA_WITH_AES_128_GCM_SHA256
 - SL_SEC_MASK_TLS_ECDHE_ECDSA_WITH_AES_256_GCM_SHA384

- SL_SEC_MASK_TLS_ECDHE_ECDSA_WITH_CHACHA20_POLY1305_SHA256
- SL_SEC_MASK_TLS_ECDHE_RSA_WITH_CHACHA20_POLY1305_SHA256
- SL_SEC_MASK_TLS_DHE_RSA_WITH_CHACHA20_POLY1305_SHA256
- Server authentication
- Client authentication
- Domain name verification
- Runtime socket upgrade to secure socket – STARTTLS
- Secure HTTP server (HTTPS)
- Trusted root-certificate catalog – Verifies that the CA used by the application is trusted and known secure content delivery
- TI root-of-trust public key – Hardware-based mechanism that allows authenticating TI as the genuine origin of a given content using asymmetric keys
- Secure content delivery – Allows encrypted file transfer to the system using asymmetric keys created by the device

Code and Data Security:

- Network passwords and certificates are encrypted and signed
- Cloning protection – Application and data files are encrypted by a unique key per device
- Access control – Access to application and data files only by using a token provided in file creation time. If an unauthorized access is detected, a tamper protection lockdown mechanism takes effect
- Encrypted and authenticated file system
- Secured boot – Authentication of the application image on every boot
- Code and data encryption – User application and data files are encrypted in sFlash
- Code and data authentication – User Application and data files are authenticated with a public key certificate
- Offloaded crypto library for asymmetric keys, including the ability to create key-pair, sign and verify data buffer
- Recovery mechanism

Device Security:

- Separate execution environments – Application processor and network processor run on separate Arm cores
- Initial secure programming – Allows for keeping the content confidential on the production line
- Debug security
 - JTAG lock
 - Debug ports lock
- True random number generator

Figure 8-2 shows the high-level structure of the CC3235S and CC3235SF devices that are contained within the CC3235MODS and CC3235MODSF modules, respectively. The application image, user data, and network information files (passwords, certificates) are encrypted using a device-specific key.

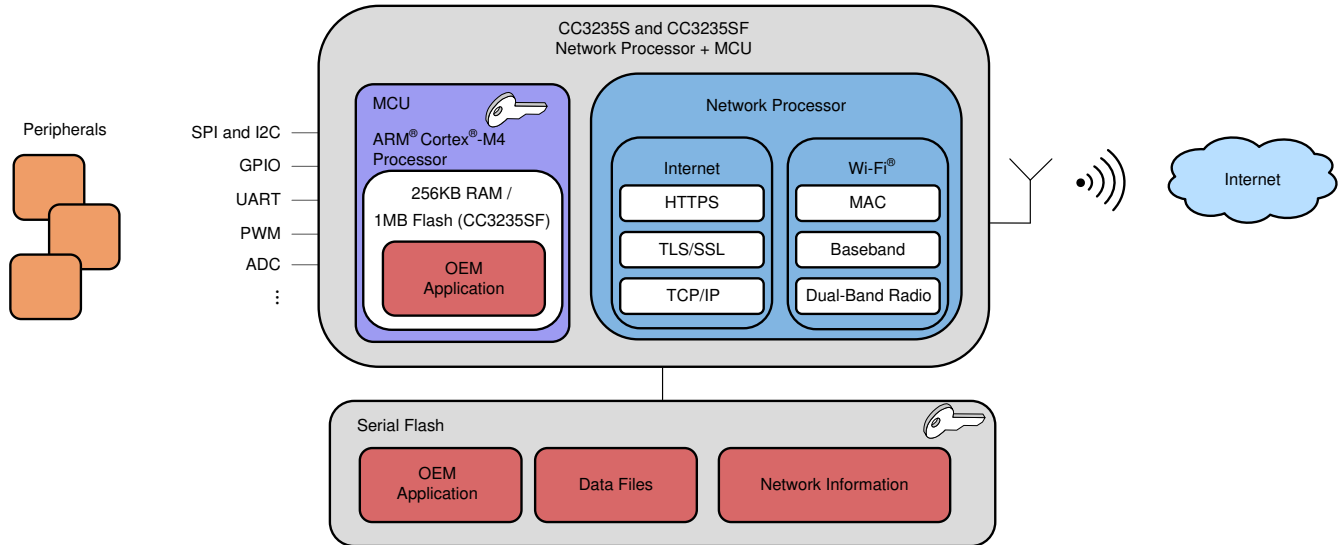

Figure 8-2. CC3235S and CC3235SF High-Level Structure

8.6 FIPS 140-2 Level 1 Certification

The Federal Information Processing Standard (FIPS) Publication 140-2 is a U.S. government computer security standard. It is commonly referred to as FIPS 140-2, and is used to accredit the design and implementation of cryptographic functions, for example within a chip. A cryptographic function within a chip security system is necessary to maintain the confidentiality and integrity of the information that is being processed.

The security functions of the CC3235x chip that is inside the CC3235MODx or CC3235MODAx module, are FIPS certified to FIPS 140-2 level 1. This certification covers topics such as: cryptographic specifications, ports and interfaces, a finite state model for the cryptographic functions, the operational environment of the function, and how cryptographic keys are managed. The certification provides the assurance that the implementation meets FIPS 140-2 level 1 standards.

8.7 Power-Management Subsystem

The CC3235MODx and CC3235MODAx power-management subsystems contain DC/DC converters to accommodate the differing voltage or current requirements of the system.

The CC3235MODx and CC3235MODAx MCU is a fully integrated module-based WLAN radio solution used on an embedded system with a wide-voltage supply range. The internal power management, including DC/DC converters and LDOs, generates all of the voltages required for the module to operate from a wide variety of input sources. For maximum flexibility, the module can operate in the modes described in the following sections.

8.7.1 VBAT Wide-Voltage Connection

In the wide-voltage battery connection, the module can be directly connected to two AA alkaline batteries. All other voltages required to operate the module are generated internally by the DC/DC converters. This scheme is the most common mode for the module because it supports wide-voltage operation from 2.3 to 3.6V.

8.8 Low-Power Operating Mode

From a power-management perspective, the CC3235MODx and CC3235MODAx MCU comprises the following two independent subsystems:

- Arm Cortex-M4 application processor subsystem
- Networking subsystem

Each subsystem operates in one of several power states.

The Arm Cortex-M4 application processor runs the user application loaded from an internal serial flash or on-module XIP flash (in CC3235MODSF). The networking subsystem runs preprogrammed TCP/IP and Wi-Fi data link layer functions.

The user program controls the power state of the application processor subsystem and can be in one of the five modes described in [Table 8-2](#).

Table 8-2. User Program Modes

APPLICATION PROCESSOR (MCU) MODE ⁽¹⁾	DESCRIPTION
MCU active mode	MCU executing code at the 80MHz state rate
MCU sleep mode	The MCU clocks are gated off in sleep mode and the entire state of the device is retained. Sleep mode offers instant wakeup. The MCU can be configured to wake up by an internal fast timer or by activity from any GPIO line or peripheral.
MCU LPDS mode	State information is lost and only certain MCU-specific register configurations are retained. The MCU can wake up from external events or by using an internal timer. (The wake-up time is less than 3ms.) Certain parts of memory can be retained while the MCU is in LPDS mode. The amount of memory retained is configurable. Users can choose to preserve code and the MCU-specific setting. The MCU can be configured to wake up using the RTC timer or by an external event on specific GPIOs as the wake-up source.
MCU hibernate mode	The lowest power mode in which all digital logic is power-gated. Only a small section of the logic directly powered by the input supply is retained. The RTC keeps running and the MCU supports wakeup from an external event or from an RTC timer expiry. Wake-up time is longer than LPDS mode at about 15ms plus the time to load the application from serial flash, which varies according to code size. In this mode, the MCU can be configured to wake up using the RTC timer or external event on a GPIO.
MCU shutdown mode	The lowest power mode system-wide. All device logics are off, including the RTC. The wake-up time in this mode is longer than hibernate at about 1.1s. To enter or exit the shutdown mode, the state of the nRESET line is changed (low to shut down, high to turn on).

(1) Modes are listed in order of power consumption, with highest power modes listed first.

The NWP can be active or in LPDS mode and takes care of its own mode transitions. When there is no network activity, the NWP sleeps most of the time and wakes up only for beacon reception (see [Table 8-3](#)).

Table 8-3. Networking Subsystem Modes

NETWORK PROCESSOR MODE	DESCRIPTION
Network active mode (processing layer 3, 2, and 1)	Transmitting or receiving IP protocol packets
Network active mode (processing layer 2 and 1)	Transmitting or receiving MAC management frames; IP processing not required
Network active listen mode	Special power-optimized active mode for receiving beacon frames (no other frames supported)
Network connected Idle	A composite mode that implements 802.11 infrastructure power save operation. The CC3235MODx and CC3235MODAx NWPs automatically go into LPDS mode between beacons and then wakes to active listen mode to receive a beacon and determine if there is pending traffic at the AP. If not, the NWP returns to LPDS mode and the cycle repeats.
Network LPDS mode	Low-power state between beacons in which the state is retained by the NWP, allowing for a rapid wake-up.
Network disabled	The network is disabled.

The operation of the application and network processor ensures that the module remains in the lowest power mode most of the time to preserve battery life.

The following examples show the use of the power modes in applications:

- A product that is continuously connected to the network in the 802.11 infrastructure power-save mode but sends and receives little data spends most of the time in connected idle, which is a composite of receiving a beacon frame and waiting for the next beacon.
- A product that is not continuously connected to the network but instead wakes up periodically (for example, every 10 minutes) to send data, spends most of the time in hibernate mode, jumping briefly to active mode to transmit data.

8.9 Memory

8.9.1 Internal Memory

The CC3235x device within the CC3235MODx and CC3235MODAx modules includes on-chip SRAM to which application programs are downloaded and executed. The application developer must share the SRAM for code and data. The micro direct memory access (μ DMA) controller can transfer data to and from SRAM and various peripherals. The CC3235x device ROM holds the rich set of peripheral drivers, which saves SRAM space. For more information on drivers, see the CC3235x API list.

8.9.1.1 SRAM

The CC3235MODx and CC3235MODAx MCU family provides 256KB of on-chip SRAM. Internal RAM is capable of selective retention during LPDS mode. This internal SRAM is at offset 0x2000 0000 of the device memory map.

Use the μ DMA controller to transfer data to and from the SRAM.

When the device enters low-power mode, the application developer can choose to retain a section of memory based on need. Retaining the memory during low-power mode provides a faster wakeup. The application developer can choose the amount of memory to retain in multiples of 64KB. For more information, see the API guide.

8.9.1.2 ROM

The internal zero-wait-state ROM of the CC3235MODx and CC3235MODAx module is at address 0x0000 0000 of the device memory and is programmed with the following components:

- Bootloader
- Peripheral driver library (DriverLib) release for product-specific peripherals and interfaces

The bootloader is used as an initial program loader (when the serial flash memory is empty). The DriverLib software library of the CC3235MODx and CC3235MODAx MCU controls on-chip peripherals with a bootloader capability. The library performs peripheral initialization and control functions, with a choice of polled or interrupt-driven peripheral support. The DriverLib APIs in ROM can be called by applications to reduce flash memory requirements and free the flash memory to be used for other purposes.

8.9.1.3 Flash Memory

The CC3235SF device within the CC3235MODSF and CC3235MODASF modules comes with an on-chip flash memory of 1MB that allows application code to execute in place while freeing SRAM exclusively for read-write data. The flash memory is used for code and constant data sections and is directly attached to the ICODE/DCODE bus of the Arm Cortex-M4 core. A 128-bit-wide instruction prefetch buffer allows maintenance of maximum performance for linear code or loops that fit inside the buffer.

The flash memory is organized as 2-KB sectors that can be independently erased. Reads and writes can be performed at word (32-bit) level.

8.9.1.4 Memory Map

[Table 8-4](#) describes the various MCU peripherals and how they are mapped to the processor memory. For more information on peripherals, see the API document.

Table 8-4. Memory Map

START ADDRESS	END ADDRESS	DESCRIPTION	COMMENT
0x0000 0000	0x0007 FFFF	On-chip ROM (bootloader + DriverLib)	
0x0100 0000	0x010F FFFF	On-chip flash (for user application code)	SF devices only
0x2000 0000	0x2003 FFFF	Bit-banded on-chip SRAM	
0x2200 0000	0x23FF FFFF	Bit-band alias of 0x2000 0000 to 0x200F FFFF	
0x4000 0000	0x4000 0FFF	Watchdog timer A0	
0x4000 4000	0x4000 4FFF	GPIO port A0	
0x4000 5000	0x4000 5FFF	GPIO port A1	
0x4000 6000	0x4000 6FFF	GPIO port A2	
0x4000 7000	0x4000 7FFF	GPIO port A3	
0x4000 C000	0x4000 CFFF	UART A0	
0x4000 D000	0x4000 DFFF	UART A1	
0x4002 0000	0x4000 07FF	I ² C A0 (master)	
0x4002 4000	0x4002 4FFF	GPIO group 4	
0x4002 0800	0x4002 0FFF	I ² C A0 (slave)	
0x4003 0000	0x4003 0FFF	General-purpose timer A0	
0x4003 1000	0x4003 1FFF	General-purpose timer A1	
0x4003 2000	0x4003 2FFF	General-purpose timer A2	
0x4003 3000	0x4003 3FFF	General-purpose timer A3	
0x400F7000	0x400F 7FFF	Configuration registers	
0x400F E000	0x400F EFFF	System control	
0x400F F000	0x400F FFFF	μDMA	
0x4200 0000	0x43FF FFFF	Bit band alias of 0x4000 0000 to 0x400F FFFF	
0x4401 0000	0x4401 0FFF	SDIO master	
0x4401 8000	0x4401 8FFF	Camera Interface	
0x4401 C000	0x4401 DFFF	McASP	
0x4402 0000	0x4402 0FFF	SSPI	Used for external serial flash
0x4402 1000	0x4402 1FFF	GSPI	Used by application processor
0x4402 5000	0x4402 5FFF	MCU reset clock manager	
0x4402 6000	0x4402 6FFF	MCU configuration space	
0x4402 D000	0x4402 DFFF	Global power, reset, and clock manager (GPRCM)	
0x4402 E000	0x4402 EFFF	MCU shared configuration	
0x4402 F000	0x4402 FFFF	Hibernate configuration	
0x4403 0000	0x4403 FFFF	Crypto range (includes apertures for all crypto-related blocks as follows)	
0x4403 0000	0x4403 0FFF	DTHE registers and TCP checksum	
0x4403 5000	0x4403 5FFF	MD5/SHA	
0x4403 7000	0x4403 7FFF	AES	
0x4403 9000	0x4403 9FFF	DES	
0xE000 0000	0xE000 0FFF	Instrumentation trace Macrocell™	
0xE000 1000	0xE000 1FFF	Data watchpoint and trace (DWT)	
0xE000 2000	0xE000 2FFF	Flash patch and breakpoint (FPB)	
0xE000 E000	0xE000 EFFF	NVIC	
0xE004 0000	0xE004 0FFF	Trace port interface unit (TPIU)	
0xE004 1000	0xE004 1FFF	Reserved for embedded trace macrocell (ETM)	
0xE004 2000	0xE00F FFFF	Reserved	

8.10 Restoring Factory Default Configuration

The module has an internal recovery mechanism that rolls back the file system to its predefined factory image or restoring the factory default parameters of the device. The factory image is kept in a separate sector on the sFLASH in a secure manner and cannot be accessed from the host processor. The following restore modes are supported:

- None—no factory restore settings
- Enable restore of factory default parameters
- Enable restore of factory image and factory default parameters

The restore process is performed by calling software APIs, or by pulling or forcing SOP[2:0] = 011 pins and toggling the nRESET pin from low to high.

The process is fail-safe and resumes operation if a power failure occurs before the restore is finished. The restore process typically takes about 8 seconds, depending on the attributes of the serial flash vendor.

8.11 Boot Modes

8.11.1 Boot Mode List

The CC3235MODx and CC3235MODAx MCU implements a sense-on-power (SoP) scheme to determine the device operation mode.

SoP values are sensed from the module pin during power up. This encoding determines the boot flow. Before the device is taken out of reset, the SoP values are copied to a register and used to determine the device operation mode while powering up. These values determine the boot flow as well as the default mapping for some of the pins (JTAG, SWD, UART0). [Table 8-5](#) lists the pull configurations.

All CC3235MODx and CC3235MODAx MCUs contain internal pulldown resistors on the SOP[2:0] lines. The application can use SOP2 for other functions after chip has powered up. However, to avoid spurious SOP values from being sensed at power up, TI strongly recommends using the SOP2 pin only for output signals. The SOP0 and SOP1 pins are multiplexed with the WLAN analog test pins and are not available for other functions.

Table 8-5. CC3235MODx and CC3235MODAx Functional Configurations

NAME	SOP[2]	SOP[1]	SOP[0]	SoP MODE	COMMENT
UARTLOAD	Pullup	Pulldown	Pulldown	LDfrUART	Factory, lab flash, and SRAM loads through the UART. The device waits indefinitely for the UART to load code. The SOP bits then must be toggled to configure the device in functional mode. Also puts JTAG in 4-wire mode.
FUNCTIONAL_2WJ	Pulldown	Pulldown	Pullup	Fn2WJ	Functional development mode. In this mode, 2-pin SWD is available to the developer. TMS and TCK are available for debugger connection.
FUNCTIONAL_4WJ	Pulldown	Pulldown	Pulldown	Fn4WJ	Functional development mode. In this mode, 4-pin JTAG is available to the developer. TDI, TMS, TCK, and TDO are available for debugger connection. The default configuration for CC3235MODx and CC3235MODAx MCUs.
UARTLOAD_FUNCTIONAL_4WJ	Pulldown	Pullup	Pulldown	LDfrUART_FnWJ	Supports flash and SRAM load through UART and functional mode. The MCU bootloader tries to detect a UART break on UART receive line. If the break signal is present, the device enters the UARTLOAD mode, otherwise, the device enters the functional mode. TDI, TMS, TCK, and TDO are available for debugger connection.

Table 8-5. CC3235MODx and CC3235MODAx Functional Configurations (continued)

NAME	SOP[2]	SOP[1]	SOP[0]	SoP MODE	COMMENT
RET_FACTORY_IMAGE	Pulldown	Pullup	Pullup	RetFactDef	When module reset is toggled, the MCU bootloader kickstarts the procedure to restore factory default images.

8.12 Hostless Mode

The SimpleLink™ Wi-Fi® CC3235MODx or CC3235MODAx devices incorporate a scripting ability that enables offloading of simple tasks from the host processor. Using simple and conditional scripts, repetitive tasks can be handled internally, which allows the host processor to remain in a low-power state. In some cases where the scripter is being used to send packets, it reduces code footprint and memory consumption. The *if-this-then-that* style of conditioning can include anything from GPIO toggling to transmitting packets.

The conditional scripting abilities can be divided into conditions and actions. The conditions define when to trigger actions. Only one action can be defined per condition, but multiple instances of the same condition may be used, so in effect, multiple actions can be defined for a single condition. In total, 16 condition and action pairs can be defined. The conditions can be simple, or complex using subconditions (using a combinatorial AND condition between them). The actions are divided into two types, those that can occur during runtime and those that can occur only during the initialization phase.

The following actions can only be performed when triggered by the preinitialization condition:

- Set roles AP, station, P2P, and Tag modes
- Delete all stored profiles
- Set connection policy
- Hardware GPIO indication allows an I/O to be driven directly from the WLAN core hardware to indicate internal signaling

The following actions may be activated during runtime:

- Send transceiver packet
- Send UDP packet
- Send TCP packet
- Increment counter increments one of the user counters by 1
- Set counter allows setting a specific value to a counter
- Timer control
- Set GPIO allows GPIO output from the device using the internal networking core
- Enter Hibernate state

Note

Consider the following limitations:

- Timing cannot be ensured when using the network scripter because some variable latency will apply depending on the utilization of the networking core.
 - The scripter is limited to 16 pairs of conditions and reactions.
 - Both timers and counters are limited to 8 instances each. Timers are limited to a resolution of 1 second. Counters are 32 bits wide.
 - Packet length is limited to the size of one packet and the number of possible packet tokens is limited to 8.
-

8.13 Device Certification and Qualification

The CC3235MODx and CC3235MODAx MCU from TI is certified for FCC, IC/ISED, ETSI/CE, Japan MIC, and SRRC. Moreover, the module is also Wi-Fi CERTIFIED™ with the ability to request a certificate transfer for Wi-Fi Alliance® members. TI customers that build products based on the CC3235MODx or CC3235MODAx MCU from TI can save in testing cost and time per product family.

Table 8-6. CC3235MODx and CC3235MODAx List of Certifications

Regulatory Body	Specification	ID (IF APPLICABLE)
FCC (USA)	Part 15C + MPE FCC RF Exposure	Z64-CC3235MOD
IC/ISED (Canada)	RSS-102 (MPE) and RSS-247 (Wi-Fi)	4511-CC3235MOD
ETSI/CE (Europe)	EN300328 v2.2.1 (2.4GHz Wi-Fi)	—
	EN301893 v2.1.1 (5GHz Wi-Fi)	—
	EN62311:2008 (MPE)	—
	EN301489-1 v2.2.1 (General EMC)	—
	EN301489-17 v3.2.0 (EMC)	—
	EN60950-1:2006/A11:2009/A1:2010/ A12:2011/A2:2013	—
MIC (Japan)	Article 49-20 of ORRE	201-190033
SRRC (China)	—	Please contact TI for more information on using SRRC ID Certification: www.ti.com/tool/SIMPLELINK-CC3XXX-CERTIFICATION

8.13.1 FCC Certification and Statement

CAUTION

FCC RF Radiation Exposure Statement:

This equipment complies with FCC radiation exposure limits set forth for an uncontrolled environment. End users must follow the specific operating instructions for satisfying RF exposure limits. This transmitter must not be co-located or operating with any other antenna or transmitter.

The CC3235MODx and CC3235MODAx modules from TI are certified for the FCC as a single-modular transmitter. The modules are FCC-certified radio modules that carries a modular grant.

You are cautioned that changes or modifications not expressly approved by the party responsible for compliance could void the user's authority to operate the equipment.

This device complies with Part 15 of the FCC Rules. Operation is subject to the following two conditions:

- This device may not cause harmful interference.
- This device must accept any interference received, including interference that may cause undesired operation of the device.

8.13.2 IC/ISED Certification and Statement

CAUTION

IC RF Radiation Exposure Statement:

To comply with IC RF exposure requirements, this device and its antenna must not be co-located or operating in conjunction with any other antenna or transmitter.

Pour se conformer aux exigences de conformité RF canadienne l'exposition, cet appareil et son antenne ne doivent pas être co-localisés ou fonctionnant en conjonction avec une autre antenne ou transmetteur.

The CC3235MODx and CC3235MODAx modules from TI are certified for IC as a single-modular transmitter. The CC3235MODx and CC3235MODAx modules from TI meet IC modular approval and labeling requirements. The IC follows the same testing and rules as the FCC regarding certified modules in authorized equipment.

This device complies with Industry Canada licence-exempt RSS standards.

Operation is subject to the following two conditions:

- This device may not cause interference.
- This device must accept any interference, including interference that may cause undesired operation of the device.

Le présent appareil est conforme aux CNR d'Industrie Canada applicables aux appareils radio exempts de licence.

L'exploitation est autorisée aux deux conditions suivantes:

- L'appareil ne doit pas produire de brouillage
- L'utilisateur de l'appareil doit accepter tout brouillage radioélectrique subi, même si le brouillage est susceptible d'en compromettre le fonctionnement.

8.13.3 ETSI/CE Certification

The CC3235MODx and CC3235MODAx modules from TI are CE certified with certifications to the appropriate EU radio and EMC directives summarized in the Declaration of Conformity and evidenced by the CE mark. The modules are tested against the new Radio Equipment Directive (RE-D). See the full text of the EU Declaration of Conformity for the [CC3235MODSM2MOB](#) and [CC3235MODSF12MOB](#) devices.

8.13.4 MIC Certification

The CC3235MODx and CC3235MODAx modules from TI are MIC certified against article 49-20 and the relevant articles of the Ordinance Regulating Radio Equipment.

Operation is subject to the following condition:

- The host system does not contain a wireless wide area network (WWAN) device.

This device operates in the W52 and W53 bands and is for indoor use only (except communication to high power radio).

8.14 Module Markings

Figure 8-3 and Figure 8-4 show the markings for the SimpleLink™ CC3235MODx module.



Figure 8-3. CC3235MODS Module Marking



Figure 8-4. CC3235MODSF Module Marking

Figure 8-5 and Figure 8-6 show the markings for the SimpleLink™ CC3235MODAx modules.





Figure 8-5. CC3235MODAS Module Marking



Figure 8-6. CC3235MODASF Module Marking

Table 8-7 lists the CC3235MODx and CC3235MODAx module markings.

Table 8-7. Module Descriptions

MARKING	DESCRIPTION
CC3235MODSM2MOB	Model
CC3235MODSF12MOB	
CC3235MODASM2MON	Model
CC3235MODASF12MON	
YMWLLLC	LTC (Lot Trace Code): <ul style="list-style-type: none"> • Y = Year • M = Month • WLLLC = Reserved for internal use
Z64-CC3235MOD	FCC ID: single modular FCC grant ID
451I-CC3235MOD	IC: single modular IC grant ID
	MIC compliance mark
 201-190033	MIC ID: modular MIC grant ID
CE	CE compliance mark

8.15 End Product Labeling

These modules are designed to comply with the FCC single modular FCC grant, FCC ID: Z64-CC3235MOD. The host system using this module must display a visible label indicating the following text:

Contains FCC ID: Z64-CC3235MOD

These modules are designed to comply with the IC single modular FCC grant, IC: 451I-CC3235MOD. The host system using this module must display a visible label indicating the following text:

Contains IC: 451I-CC3235MOD

This module is designed to comply with the JP statement, 201-190033. The host system using this module must display a visible label indicating the following text:

Contains transmitter module with certificate number: 201-190033

8.16 Manual Information to the End User

The OEM integrator must be aware not to provide information to the end user regarding how to install or remove this RF module in the user's manual of the end product which integrates this module.

The end user manual must include all required regulatory information and warnings as shown in this manual.

9 Applications, Implementation, and Layout

Note

Information in the following applications sections is not part of the TI component specification, and TI does not warrant its accuracy or completeness. TI's customers are responsible for determining suitability of components for their purposes. Customers should validate and test their design implementation to confirm system functionality.

9.1 Typical Application

9.1.1 BLE/2.4GHz Radio Coexistence

The CC3235MODx and CC3235MODAx devices are designed to support BLE/2.4GHz radio coexistence. Because WLAN is inherently more tolerant to time-domain disturbances, the coexistence mechanism gives priority to the Bluetooth® low energy entity over the WLAN. Bluetooth® low energy operates in the 2.4GHz band, therefore the coexistence mechanism does not affect the 5GHz band. The CC3235MODx and CC3235MODAx device can operate normally on the 5GHz band, while the Bluetooth® low energy works on the 2.4GHz band without mutual interference.

The following coexistence modes can be configured by the user:

- Off mode or intrinsic mode
 - No BLE/2.4GHz radio coexistence, or no synchronization between WLAN and Bluetooth® low energy—in case Bluetooth® low energy exists in this mode, collisions can randomly occur.
- Time Division Multiplexing (TDM, Dual Antenna)
 - Dual-band Wi-Fi (see [Figure 9-1](#))

In this mode, the WLAN can operate on either a 2.4 or 5GHz band and Bluetooth® low energy operates on the 2.4GHz band.

[Figure 9-1](#) shows the dual antenna implementation of a complete Bluetooth® low energy and WLAN coexistence network with the WLAN operating on either a 2.4 or a 5GHz band. Note in this implementation a Coex switch is not required and only a single GPIO from the BLE device to the CC3235MOD device is needed. In addition, the CC3235MODx's antenna is external while the CC3235MODAx's antenna is integrated.

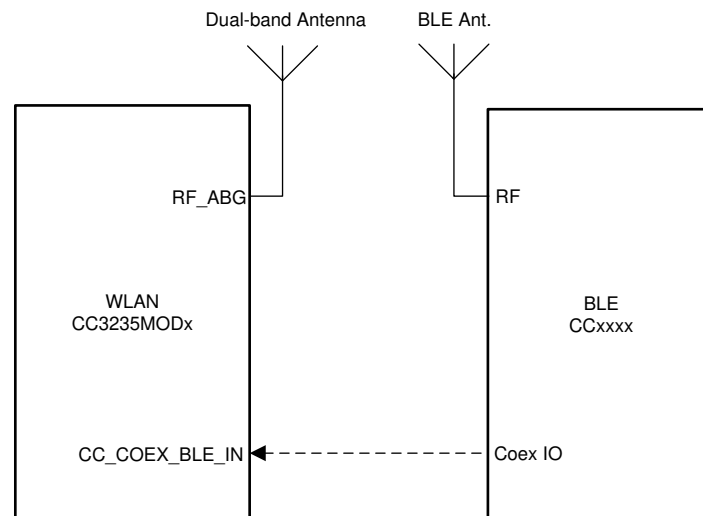

Figure 9-1. Dual-Antenna Coexistence Mode Block Diagram

9.1.2 Antenna Selection (CC3235MODx only)

The CC3235MODx device is designed to also support antenna selection and is controlled from Image Creator. When enabled, there are two options possible options:

- ANT 1: When selected, the GPIOs that are defined for antenna selection will set the RF path for antenna 1.
- ANT 2: When selected, the GPIOs that are defined for antenna selection will set the RF path for antenna 2.
- Autoselect: When selected, during a scan and prior to connecting to an AP, CC3235MODx device will determine the best RF path and select the appropriate antenna ^{13 14}. The result is saved as part of the profile.

Figure 9-2 shows the antenna selection implementation for Wi-Fi, with BLE operating on its own antenna. Note in this implementation, only a single GPIO from the BLE device to the CC3235MODx device is required. The Antenna switch ¹⁵ is controlled by two GPIO lines from the CC3235MODx device. Section 6.3 lists which GPIOs can be used for Antenna Selection.

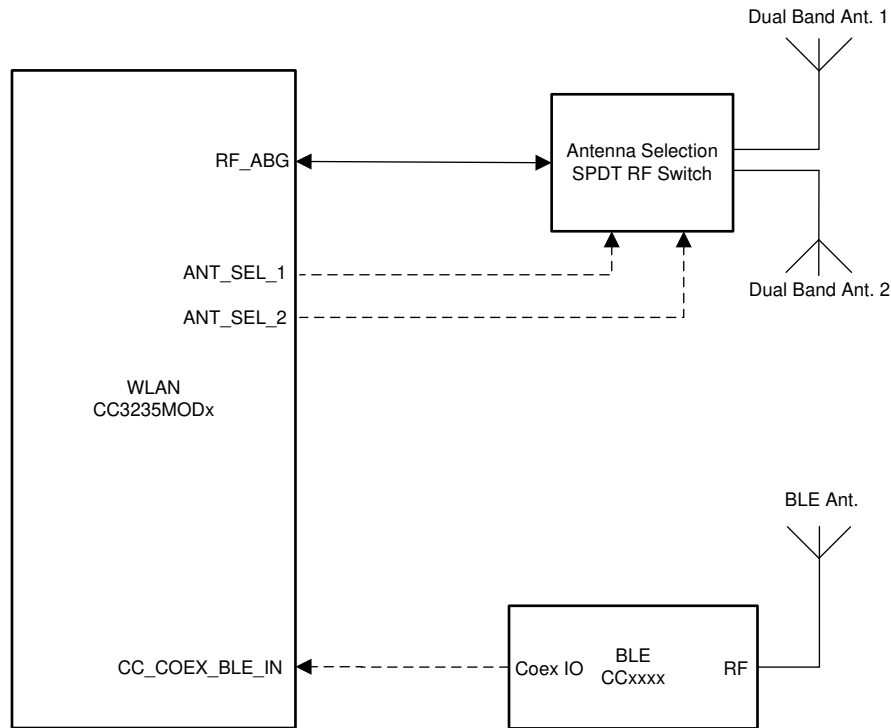

Figure 9-2. Coexistence Solution with Wi-Fi Antenna Selection and Dedicated BLE Antenna

¹³ When selecting Autoselect via the API, a reset is required in order for the CC3235MODx device to determine the best antenna for use.

¹⁴ Refer to the [Uniflash with Image Creator User Guide](#) for more information.

¹⁵ The recommended Antenna switch is the Richwave RTC6608OSP.

9.1.3 Typical Application Schematic (CC3235MODx)

Figure 9-3 shows the typical application schematic using the CC3235MODx module. See the full reference schematic for [CC3235MODx](#).

Note that the CC3235MODx and CC3235MODAx modules share the same reference schematic. The difference between the two references is the antenna and its matching circuitry. The CC3235MODAx's pin 31 is not accessible to the designer because it is directly tied to the integrated antenna.

Note

The following guidelines are recommended for implementation of the RF design:

- Ensure an RF path is designed with an impedance of 50Ω .
 - Tuning of the antenna impedance π matching network is recommended after manufacturing of the PCB to account for PCB parasitics.
 - π or L matching and tuning may be required between cascaded passive components on the RF path.
-

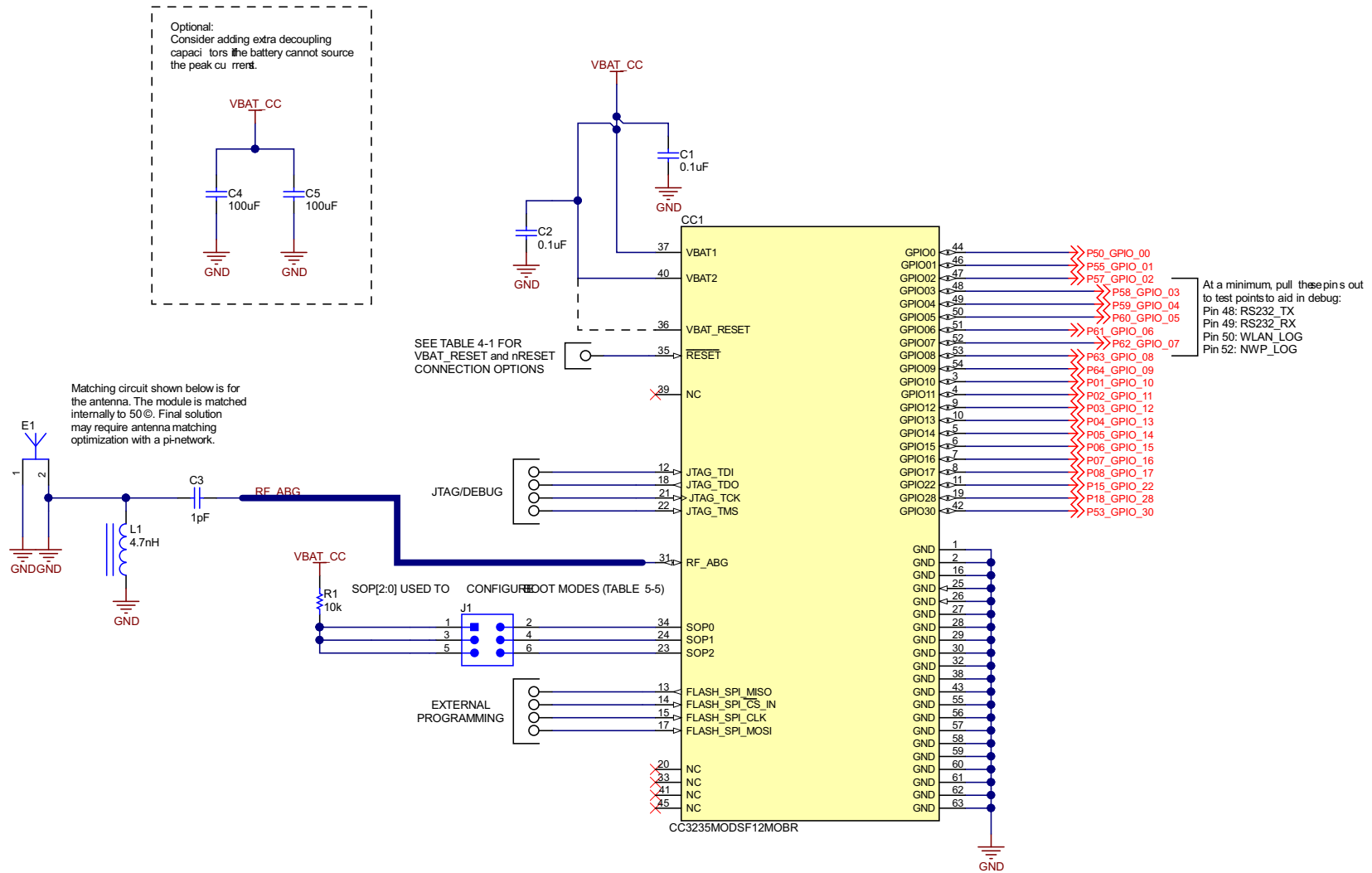

Figure 9-3. CC3235MODx Typical Application Schematic

Table 9-1 provides the bill of materials for a typical application using the CC3235MODx module in Figure 9-3.

For full operation reference design, see the [CC3235MODAx SimpleLink™](#) and [Internet of Things Hardware Design Files](#).

Table 9-1. Bill of Materials

QTY	PART REFERENCE	VALUE	MANUFACTURER	PART NUMBER	DESCRIPTION
2	C1, C2	0.1µF	Murata	GRM155R61A104KA01D	Capacitor, ceramic, 0.1µF, 10V, ±10%, X5R, 0402
1	C3	1pF	Murata	GRM1555C1H1R0CA01D	Capacitor, ceramic, 1pF, 50V, ±5%, C0G/NP0, 0402
2	C4, C5	100µF	Murata	LMK325ABJ107MMHT	Capacitor, ceramic, 100µF, 10V, ±20%, X5R, AEC-Q200 Grade 3, 1210
1	E1	2.4GHz, 5GHz Ant	Ethertronics	M830520	Antenna Bluetooth WLAN Zigbee®
1	L1	4.7nH	Murata	LQG15HS4N7C02D	Inductor, Multilayer, Air Core, 4.7nH, 0.7 A, 0.16Ω, SMD
1	R1	10k	Vishay-Dale	CRCW040210K0JNED	RES, 10k, 5%, 0.063 W, AEC-Q200 Grade 0, 0402
1	CC1	CC3235MODx	Texas Instruments	CC3235MODSM2MOB/ CC3235MODSF12MOB	SimpleLink™ Wi-Fi® and Internet-of-Things Module Solution, a Single-Chip Wireless Dual-Band MCU, MOB0063A

9.1.4 Typical Application Schematic (CC3235MODAx)

Figure 9-4 shows the typical application schematic using the CC3235MODAx module. See the full reference schematic for [CC3235MODAx](#).

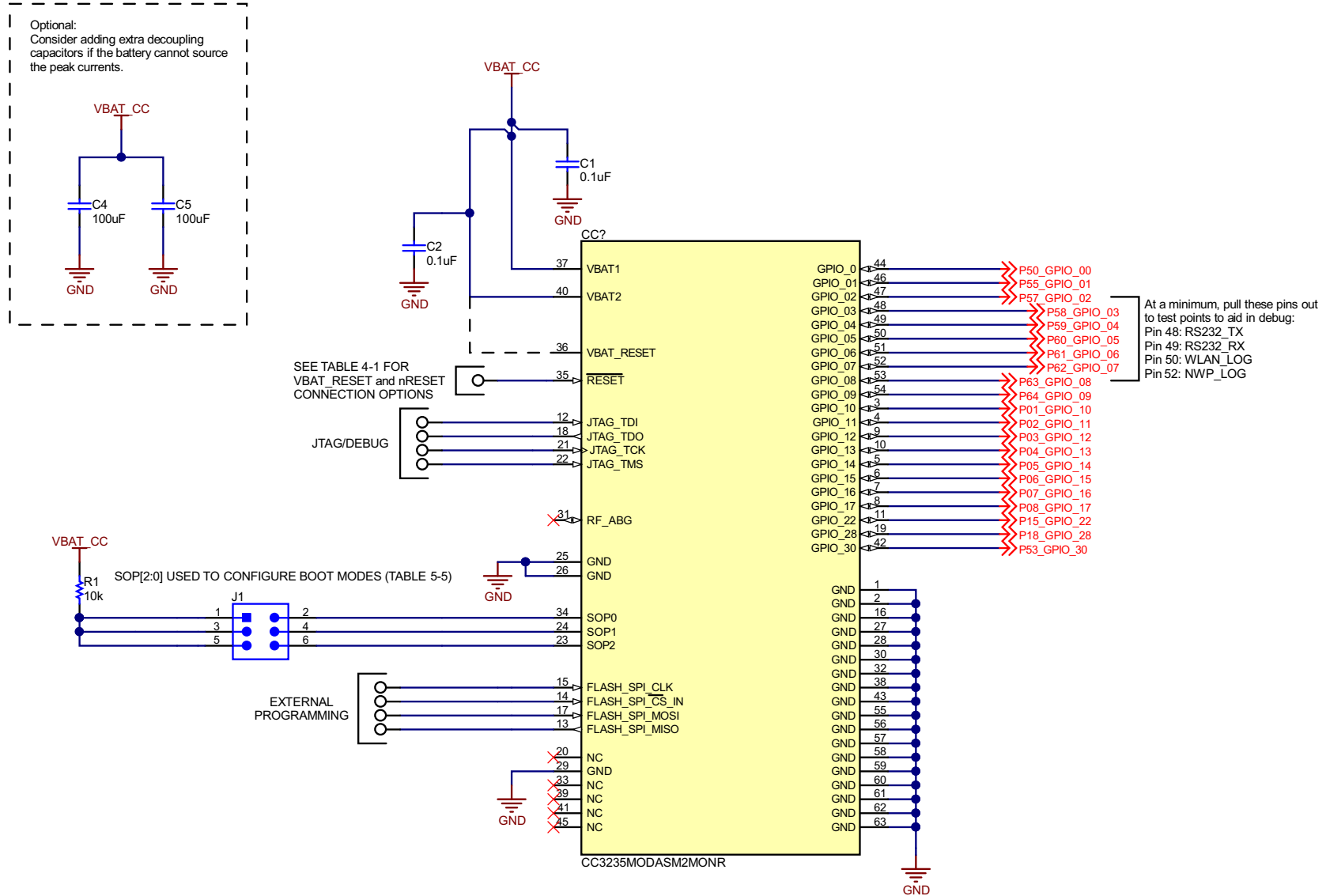

Figure 9-4. CC3235MODAx Typical Application Schematic

Table 9-2 provides the bill of materials for a typical application using the CC3235MODAx module in Figure 9-4.

For full operation reference design, see the [CC3235MODAx SimpleLink™](#) and [Internet of Things Hardware Design Files](#).

Table 9-2. Bill of Materials

QTY	PART REFERENCE	VALUE	MANUFACTURER	PART NUMBER	DESCRIPTION
2	C1, C2	0.1µF	Murata	GRM155R61A104KA01D	Capacitor, ceramic, 0.1µF, 10V, ±10%, X5R, 0402
2	C4, C5	100µF	Murata	LMK325ABJ107MMHT	Capacitor, ceramic, 100µF, 10V, ±20%, X5R, AEC-Q200 Grade 3, 1210
1	R1	10k	Vishay-Dale	CRCW040210K0JNED	RES, 10k, 5%, 0.063W, AEC-Q200 Grade 0, 0402
1	CC1	CC3235MODAx	Texas Instruments	CC3235MODASM2MON/ CC3235MODASF12MON	SimpleLink™ Wi-Fi® and Internet-of-Things Module Solution, a Single-Chip Wireless Dual-Band MCU, MON0063A

9.2 Device Connection and Layout Fundamentals

9.2.1 Power Supply Decoupling and Bulk Capacitors

Depending upon routing resistors and battery type, TI recommends adding two 100µF ceramic capacitors to help provide the peak current drawn by the CC3235MODx and CC3235MODAx modules.

Note

The module enters a brown-out condition whenever the input voltage dips below V_{BROWN} (see [Figure 7-4](#) and [Figure 7-5](#)). This condition must be considered during design of the power supply routing specifically if operating from a battery. For more details on brown-out consideration, see [Section 7.8](#).

9.2.2 Reset

The module features an internal RC circuit to reset the device during power ON. The nRESET pin must be held below 0.6V for at least 5ms for the device to reset successfully.

9.2.3 Unused Pins

All unused pins can be left unconnected without the concern of having leakage current.

9.3 PCB Layout Guidelines

This section details the PCB guidelines to speed up the PCB design using the CC3235MODx and CC3235MODAx. The integrator of the CC3235MODx and CC3235MODAx modules must comply with the PCB layout recommendations described in the following subsections to minimize the risk with regulatory certifications for the FCC, IC/ISED, ETSI/CE, MIC, and SRRC. Moreover, TI recommends customers follow the guidelines described in this section to achieve similar performance to that obtained with the TI reference design.

9.3.1 General Layout Recommendations

Ensure that the following general layout recommendations are followed:

- Have a solid ground plane and ground vias under the module for stable system and thermal dissipation.
- Do not run signal traces underneath the module on a layer where the module is mounted.

9.3.2 CC3235MODx RF Layout Recommendations

The RF section of this wireless module gets top priority in terms of layout. It is very important for the RF section to be laid out correctly to ensure optimum performance from the module. A poor layout can cause low-output power, EVM degradation, sensitivity degradation, and mask violations.

[Figure 9-5](#) shows the RF placement and routing of the CC3235MODx module with external antenna.

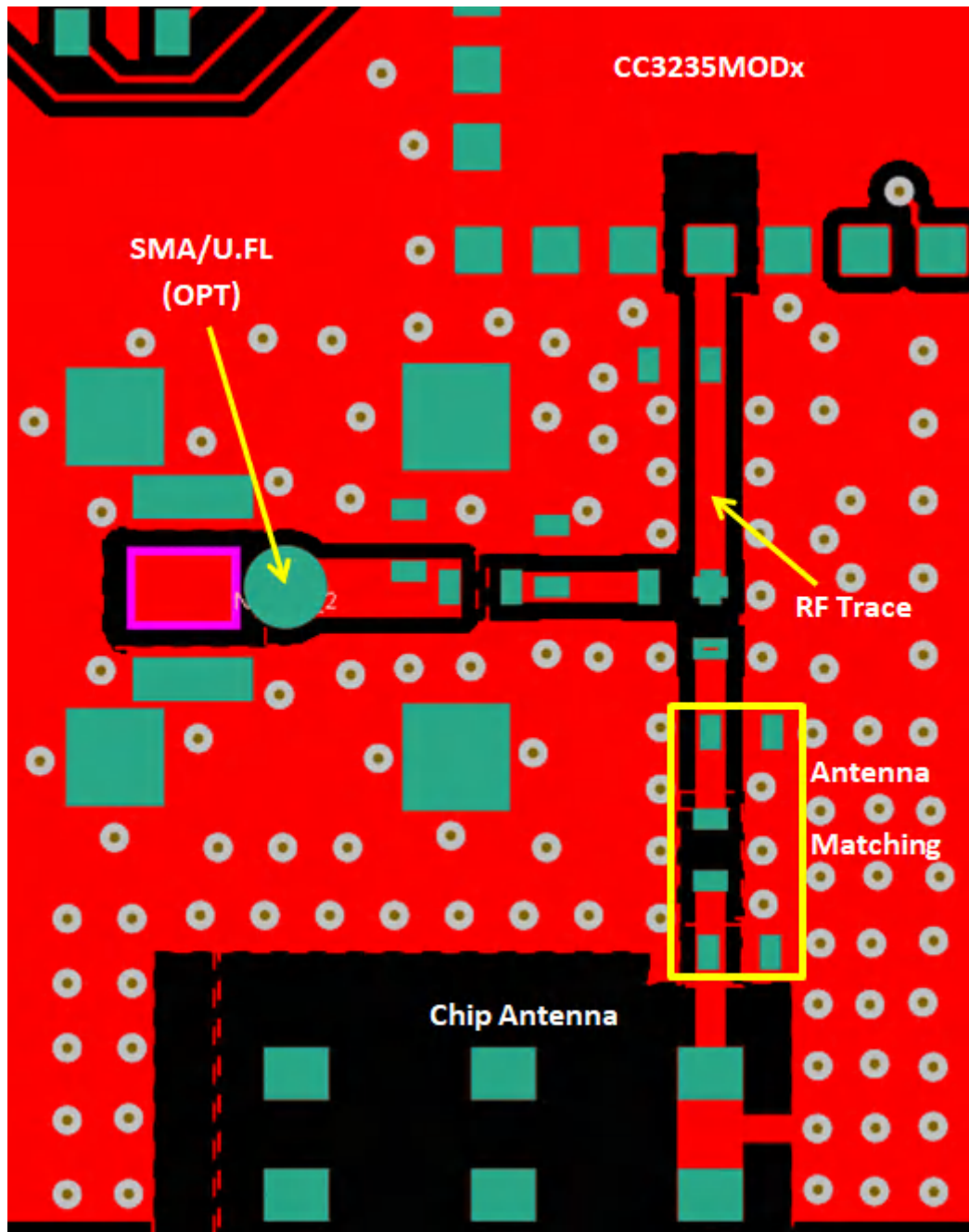
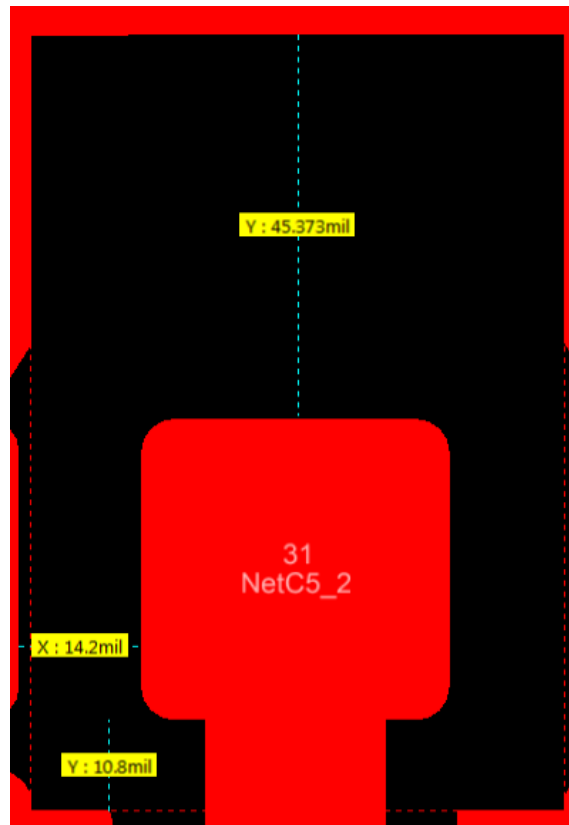

Figure 9-5. RF Section Layout

Follow these RF layout recommendations for the CC3235MODx device:

- RF traces must have 50 Ω impedance.
- RF trace bends must be made with gradual curves, and 90° bends must be avoided.
- RF traces must not have sharp corners.
- There must be no traces or ground under the antenna section.
- RF traces must have via stitching on the ground plane beside the RF trace on both sides.
- RF traces must be as short as possible. The antenna, RF traces, and the module must be on the edge of the PCB product in consideration of the product enclosure material and proximity.

For optimal RF performance, ensure the copper cut out on the top layer under the RF-BG pin (pin 31) is as shown in [Figure 9-6](#).



Copyright © 2017, Texas Instruments Incorporated

Figure 9-6. Top Layer Copper Pullback on RF Pads

9.3.2.1 Antenna Placement and Routing

The antenna is the element used to convert the guided waves on the PCB traces to the free space electromagnetic radiation. The placement and layout of the antenna are the keys to increased range and data rates. [Table 9-3](#) provides a summary of the recommended antennas to use with the CC3235MODx module.

Table 9-3. Antenna Guidelines

SR NO.	GUIDELINES
1	Place the antenna on an edge or corner of the PCB.
2	Ensure that no signals are routed across the antenna elements on all the layers of the PCB.
3	Most antennas, including the chip antenna used on the LaunchPad™, require ground clearance on all the layers of the PCB. Ensure that the ground is cleared on the inner layers as well.
4	Ensure that there is a provision to place matching components for the antenna. These must be tuned for the best return loss when the complete board is assembled. Any plastics or casing must also be mounted while tuning the antenna because this can impact the impedance.
5	Ensure that the antenna impedance is 50Ω because the module is rated to work only with a 50Ω system.
6	In the case of printed antenna, ensure that the simulation is performed with the solder mask in consideration.
7	Ensure that the antenna has a near omnidirectional pattern.
8	The feed point of the antenna is required to be grounded. This is only for the antenna type used on the CC3235MODx Launchpad. See the specific antenna data sheets for the recommendations.

[Table 9-4](#) lists the recommended antennas to use with the CC3235MODx module. Other antennas may be available for use with the CC3235MODx modules.

Table 9-4. Recommended Components

CHOICE	PART NUMBER	MANUFACTURER	NOTES
1	M830520	Ethertronics	Can be placed on the edge of the PCB and uses much less PCB space

9.3.2.2 Transmission Line Considerations

The RF signal from the module is routed to the antenna using a Coplanar Waveguide with ground (CPW-G) structure. CPW-G structure offers the maximum amount of isolation and the best possible shielding to the RF lines. In addition to the ground on the L1 layer, placing GND vias along the line also provides additional shielding.

Figure 9-7 shows a cross section of the coplanar waveguide with the critical dimensions.

Figure 9-8 shows the top view of the coplanar waveguide with GND and via stitching.

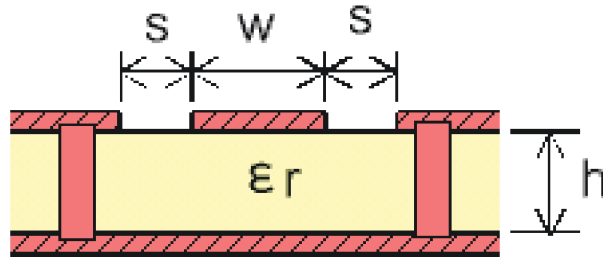

Figure 9-7. Coplanar Waveguide (Cross Section)

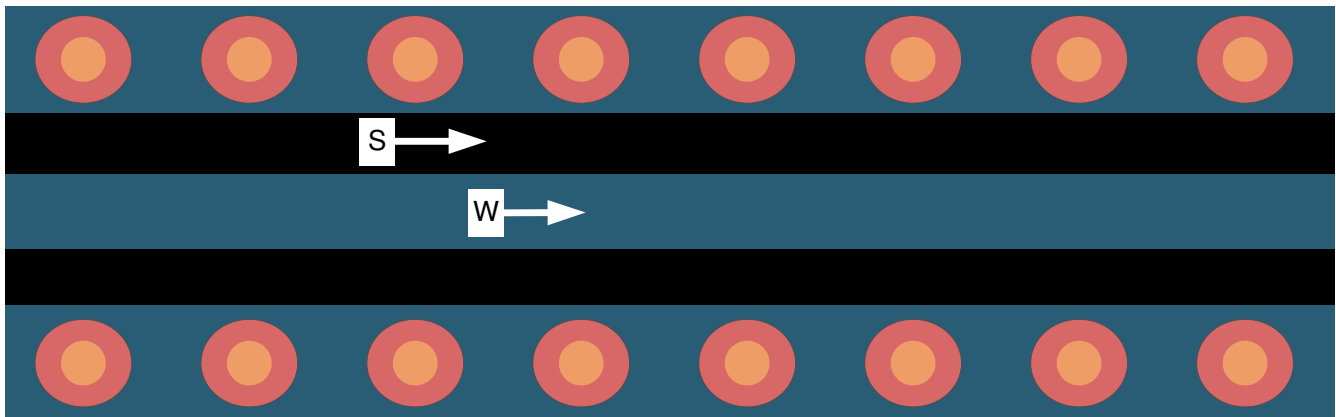

Figure 9-8. CPW With GND and Via Stitching (Top View)

The recommended values for the PCB are provided for 2-layer boards in [Table 9-5](#) and 4-layer boards in [Table 9-6](#).

Table 9-5. Recommended PCB Values for 2-Layer Board (L1 to L2 = 42.1 mils)

PARAMETER	VALUE	UNIT
W	26	mils
S	5.5	mils
H	42.1	mils
Er (FR-4 substrate)	4.2	F/m

Table 9-6. Recommended PCB Values for 4-Layer Board (L1 to L2 = 16 mils)

PARAMETER	VALUE	UNITS
W	21	mils
S	10	mils
H	16	mils
Er (FR-4 substrate)	4.5	F/m

9.3.3 CC3235MODAx RF Layout Recommendations

Use the following guidelines to lay out the CC3235MODAx module with an integrated antenna, as shown in Figure 9-9.

- The module must have an overhang of 1 mm from the PCB edge.
- The module must have a 6 mm clearance on all layers (no copper) to the left and right of the module placement.
- There must be at least one ground-reference plane under the module on the main PCB.

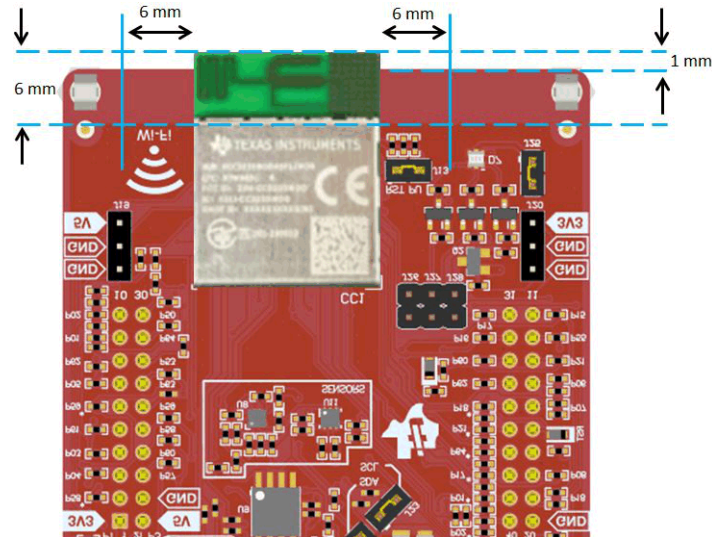

Figure 9-9. CC3235MODAx Layout Guidelines

10 Environmental Requirements and SMT Specifications

10.1 PCB Bending

The PCB follows IPC-A-600J for PCB twist and warpage < 0.75% or 7.5 mil per inch.

10.2 Handling Environment

10.2.1 Terminals

The product is mounted with motherboard through land-grid array (LGA). To prevent poor soldering, do not make skin contact with the LGA portion.

10.2.2 Falling

The mounted components will be damaged if the product falls or is dropped. Such damage may cause the product to malfunction.

10.3 Storage Condition

10.3.1 Moisture Barrier Bag Before Opened

A moisture barrier bag must be stored in a temperature of less than 30°C with humidity under 85% RH. The calculated shelf life for the dry-packed product will be 24 months from the date the bag is sealed.

10.3.2 Moisture Barrier Bag Open

Humidity indicator cards must be blue, < 30%.

10.4 PCB Assembly Guide

The wireless MCU modules are packaged in a substrate base Leadless Quad Flatpack (QFM) package. Components were mounted onto the substrate with standard SMT process with the additional of a metal lid covering the top of the module. The module are designed with pull back leads for easy PCB layout and board mounting.

10.4.1 PCB Land Pattern and Thermal Vias

We recommended a solder mask-defined land pattern to provide a consistent soldering pad dimension in order to obtain better solder balancing and solder joint reliability. The PCB land pattern is 1:1 to the module soldering pad dimension. Thermal vias on PCB connected to other metal plane are for thermal dissipation purposes. It is critical to have sufficient thermal vias to avoid device thermal shutdown. Recommended vias size is 0.2mm and position not directly under solder paste to avoid solder dripping into the vias.

10.4.2 SMT Assembly Recommendations

The module surface mount assembly operations include:

- Screen printing the solder paste on the PCB
- Monitor the solder paste volume (uniformity)
- Package placement using standard SMT placement equipment
- X-ray pre-reflow check—paste bridging
- Reflow
- X-ray post-reflow check—solder bridging and voids

10.4.3 PCB Surface Finish Requirements

A uniform PCB plating thickness is key for high assembly yield. For an electroless nickel immersion gold finish, the gold thickness should range from 0.05 μ m to 0.20 μ m to avoid solder joint embrittlement. Using a PCB with Organic Solderability Preservative (OSP) coating finish is also recommended as an alternative to Ni-Au.

10.4.4 Solder Stencil

Solder paste deposition using a stencil-printing process involves the transfer of the solder paste through pre-defined apertures with the application of pressure. Stencil parameters such as aperture area ratio and the fabrication process have a significant impact on paste deposition. Inspection of the stencil prior to placement of package is highly recommended to improve board assembly yields.

10.4.5 Package Placement

Packages can be placed using standard pick and place equipment with an accuracy of ± 0.05 mm. Component pick and place systems are composed of a vision system that recognizes and positions the component and a mechanical system that physically performs the pick and place operation. Two commonly used types of vision systems are:

- A vision system that locates a package silhouette
- A vision system that locates individual pads on the interconnect pattern

The second type renders more accurate placements but tends to be more expensive and time consuming. Both methods are acceptable since the parts align due to a self-centering features of the solder joint during solder reflow. It is recommended to release the package to 1 to 2 mils into the solder paste or with minimum force to avoid causing any possible damage to the thinner packages.

10.4.6 Solder Joint Inspection

After surface mount assembly, transmission X-ray should be used for sample monitoring of the solder attachment process. This identifies defects such as solder bridging, shorts, opens, and voids. It is also recommended to use side view inspection in addition to X-rays to determine if there are "Hour Glass" shaped solder and package tilting existing. The "Hour Glass" solder shape is not a reliable joint. 90° mirror projection can be used for side view inspection.

10.4.7 Rework and Replacement

TI recommends removal of modules by rework station applying a profile similar to the mounting process. Using a heat gun can sometimes cause damage to the module by overheating.

10.4.8 Solder Joint Voiding

TI recommends to control solder joint voiding to be less than 30% (per IPC-7093). Solder joint voids could be reduced by baking of components and PCB, minimized solder paste exposure duration, and reflow profile optimization.

10.5 Baking Conditions

Products require baking before mounting if:

- Humidity indicator cards read > 30%
- Temp < 30°C, humidity < 70% RH, over 96 hours

Baking condition: 90°C, 12 to 24 hours

Baking times: 1 time

10.6 Soldering and Reflow Condition

- Heating method: Conventional convection or IR convection
- Temperature measurement: Thermocouple $d = 0.1\text{mm}$ to 0.2mm CA (K) or CC (T) at soldering portion or equivalent method
- Solder paste composition: SAC305
- Allowable reflow soldering times: two times based on the reflow soldering profile (see [Figure 10-1](#))
- Temperature profile: Reflow soldering is done according to the temperature profile (see [Figure 10-1](#)).
- Peak temperature: 260°C

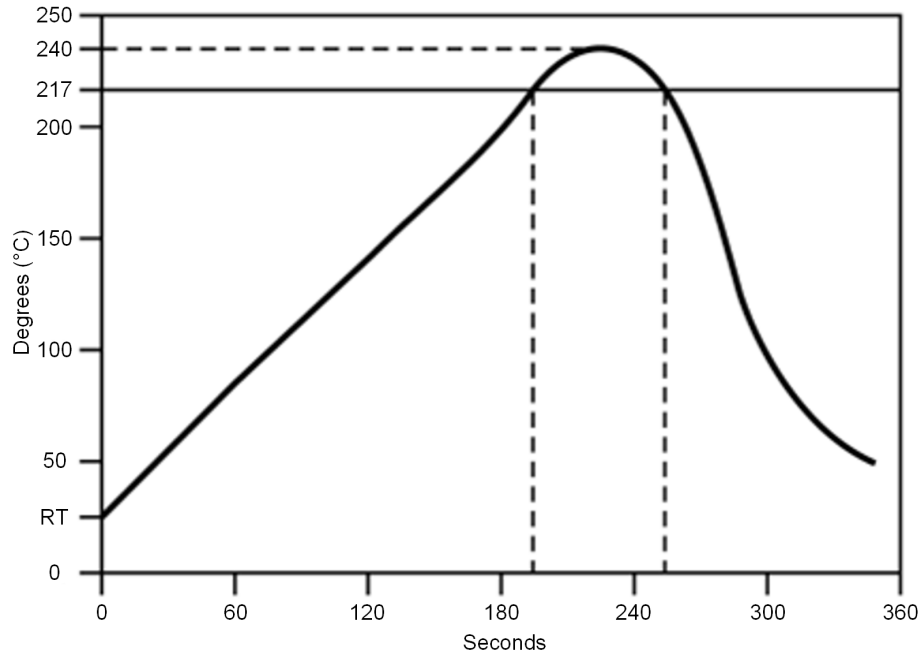

Figure 10-1. Temperature Profile for Evaluation of Solder Heat Resistance of a Component (at Solder Joint)

Table 10-1. Temperature Profile

Profile Elements	Convection or IR ⁽¹⁾
Peak temperature range	235 to 240°C typical (260°C maximum)
Pre-heat / soaking (150 to 200°C)	60 to 120 seconds
Time above melting point	60 to 90 seconds
Time with 5°C to peak	30 seconds maximum
Ramp up	$< 3^{\circ}\text{C} / \text{second}$
Ramp down	$< -6^{\circ}\text{C} / \text{second}$

(1) For details, refer to the solder paste manufacturer's recommendation.

Note

TI does not recommend the use of conformal coating or similar material on the SimpleLink™ module. This coating can lead to localized stress on the solder connections inside the module and impact the module reliability. Use caution during the module assembly process to the final PCB to avoid the presence of foreign material inside the module.

11 Device and Documentation Support

TI offers an extensive line of development tools. Tools and software to evaluate the performance of the device, generate code, and develop solutions are listed in this section.

11.1 Development Tools and Software

For the most up to date list of Development Tools and Software, visit the [CC3235MOD tools and software](#) page. Or, click on the *Alert me* button in the top-right corner of the page, to stay informed of updates related to the CC3235MOD.

Pin Mux Tool

The supported devices are: CC3200, CC3220x, and CC3235x.

The Pin Mux Tool is a software tool that provides a graphical user interface (GUI) for configuring pin multiplexing settings, resolving conflicts, and specifying I/O cell characteristics for MPUs from TI. Results are output as C header/code files that can be imported into software development kits (SDKs) or used to configure customers' custom software. Version 3 of the Pin Mux Tool adds the capability of automatically selecting a mux configuration that satisfies the entered requirements.

SimpleLink™ Wi-Fi® Starter Pro

The supported devices are: CC3100, CC3200, CC3120R, CC3220x, CC3135, and CC3235x.

The SimpleLink™ Wi-Fi® Starter Pro mobile App is a new mobile application for SimpleLink™ provisioning. The app goes along with the embedded provisioning library and example that runs on the device side (see [SimpleLink™ Wi-Fi® SDK plugin](#) and [TI SimpleLink™ CC32XX Software Development Kit \(SDK\)](#)). The new provisioning release is a TI recommendation for Wi-Fi® provisioning using SimpleLink™ Wi-Fi® products. The provisioning release implements advanced AP mode and SmartConfig™ technology provisioning with feedback and fallback options to ensure successful process has been accomplished. Customers can use both embedded library and the mobile library for integration to their end products.

SimpleLink™ CC32XX Software Development Kit (SDK)

The CC3235x devices are supported.

The SimpleLink™ CC32XX SDK contains drivers for the CC3235 programmable MCU, more than 30 sample applications, and documentation needed to use the solution. It also contains the flash programmer, a command line tool for flashing software, configuring network and software parameters (SSID, access point channel, network profile, BS NIEW), system files, and user files (certificates, web pages, and more). This SDK can be used with TI's SimpleLink™ Wi-Fi® CC3235 LaunchPad™ development kits.

Uniflash Standalone Flash Tool for TI Microcontrollers (MCU), Sitara Processors & SimpleLink Devices

The supported devices are CC3120R, CC3220x, CC3135, and CC3235x.

CCS Uniflash is a standalone tool used to program on-chip flash memory on TI MCUs and on-board flash memory for Sitara™ processors. Uniflash has a GUI, command line, and scripting interface. CCS Uniflash is available free of charge.

SimpleLink™ Wi-Fi® Radio Testing Tool

The supported devices are: CC3100, CC3200, CC3120R, CC3220, CC3135, and CC3235x.

The SimpleLink™ Wi-Fi® Radio Testing Tool is a Windows-based software tool for RF evaluation and testing of SimpleLink™ Wi-Fi® CC3x20 and CC3x35 designs during development and certification. The tool enables low-level radio testing capabilities by manually setting the radio into transmit or receive modes. Using the tool requires familiarity and knowledge of radio circuit theory and radio test methods.

Created for the internet-of-things (IoT), the SimpleLink™ Wi-Fi® CC31xx and CC32xx family of devices include on-chip Wi-Fi®, Internet, and robust security protocols with no prior Wi-Fi® experience needed for faster development. For more information on these devices, visit [SimpleLink™ Wi-Fi® family](#), [Internet-on-a chip™ solutions](#).

*UniFlash Standalone
Flash Tool for TI
Microcontrollers (MCU),
Sitara™ Processors
and SimpleLink™
Devices*

CCS UniFlash is a standalone tool used to program on-chip flash memory on TI MCUs and on-board flash memory for Sitara™ processors. UniFlash has a GUI, command line, and scripting interface. CCS UniFlash is available free of charge.

11.2 Firmware Updates

TI updates features in the service pack for this module with no published schedule. Due to the ongoing changes, TI recommends users have the latest service pack in their module for production.

To stay informed, sign up for updates using the SDK Alert me button in the top-right corner of the product page, or visit <http://www.ti.com/tool/download/SIMPLELINK-CC32XX-SDK>.

11.3 Device Nomenclature

To designate the stages in the product development cycle, TI assigns prefixes to the part numbers of the CC3235MODx and CC3235MODAx and support tools (see [Figure 11-1](#)).

To designate the stages in the product development cycle, TI assigns prefixes to the part numbers of all microprocessors (MPUs) and support tools. Each device has one of three prefixes: X, P, or null (no prefix) (for example, CC3235MODx and CC3235MODAx). Texas Instruments recommends two of three possible prefix designators for its support tools: TMDX and TMDS. These prefixes represent evolutionary stages of product development from engineering prototypes (TMDX) through fully qualified production devices and tools (TMDS).

Device development evolutionary flow:

- X** Experimental device that is not necessarily representative of the final device's electrical specifications and may not use production assembly flow.
- P** Prototype device that is not necessarily the final silicon die and may not necessarily meet final electrical specifications.
- null** Production version of the silicon die that is fully qualified.

Support tool development evolutionary flow:

- TMDX** Development-support product that has not yet completed Texas Instruments internal qualification testing.
- TMDS** Fully-qualified development-support product.

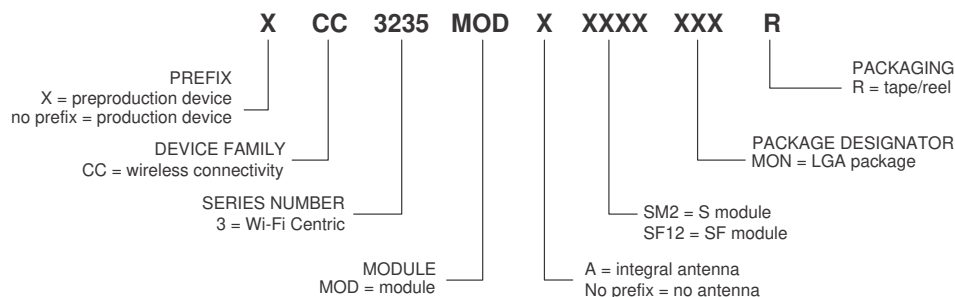

Figure 11-1. CC3235MODx and CC3235MODAx Module Nomenclature

For orderable part numbers of the CC3235MODx and CC3235MODAx devices in the QFM package type, see [Section 13.2](#), see ti.com, or contact your TI sales representative.

11.4 Documentation Support

To receive notification of documentation updates — including silicon errata — go to the [CC3235MOD product folder](#) on ti.com. In the upper-right corner, click on *Alert me* to receive a weekly digest of any product information that has changed. For change details, check the revision history of any revised document.

The current documentation that describes the processor, related peripherals, and other technical collateral is as follows.

Application Reports

[CC3135 and CC3235 SimpleLink™ Wi-Fi® Embedded Programming User Guide](#)

CC3135 and CC3235 SimpleLink Wi-Fi Embedded Programming User Guide

[SimpleLink™ CC3135, CC3235 Wi-Fi® Internet-on-a chip™ Networking Sub-System Power Management](#)

This application report describes the best practices for power management and extended battery life for embedded low-power Wi-Fi devices such as the SimpleLink Wi-Fi Internet-on-a chip solution from Texas Instruments.

[SimpleLink™ CC31xx, CC32xx Wi-Fi® Internet-on-a chip™ Solution Built-In Security Features](#)

The SimpleLink Wi-Fi CC31xx and CC32xx Internet-on-a chip family of devices from Texas Instruments offer a wide range of built-in security features to help developers address a variety of security needs, which is achieved without any processing burden on the main microcontroller (MCU). This document describes these security-related features and provides recommendations for leveraging each in the context of practical system implementation.

[SimpleLink™ CC3135, CC3235 Wi-Fi® and Internet-of-Things Over-the-Air Update](#)

This document describes the OTA library for the SimpleLink Wi-Fi CC3x35 family of devices from Texas Instruments and explains how to prepare a new cloud-ready update to be downloaded by the OTA library.

[SimpleLink™ CC3135, CC3235 Wi-Fi® Internet-on-a chip™ Solution Device Provisioning](#)

This guide describes the provisioning process, which provides the SimpleLink Wi-Fi device with the information (network name, password, and so forth) needed to connect to a wireless network.

[Transfer of TI's Wi-Fi® Alliance Certifications to Products Based on SimpleLink™](#)

This document explains how to employ the Wi-Fi® Alliance (WFA) derivative certification transfer policy to transfer a WFA certification, already obtained by Texas Instruments, to a system you have developed.

[Using Serial Flash on SimpleLink™ CC3135 and CC3235 Wi-Fi® and Internet-of-Things Devices](#)

This application note is divided into two parts. The first part provides important guidelines and best-practice design techniques to consider when choosing and embedding a serial Flash paired with the CC3135 and CC3235 (CC3x35) devices. The second part describes the file system, along with guidelines and considerations for system designers working with the CC3x35 devices.

More Literature

[CC3235MODx SimpleLink™ Wi-Fi® and Internet-of-Things Hardware Design Files](#)

[CC3220MODAx SimpleLink™ Wi-Fi® and Internet-of-Things Hardware Design Files](#)

[CC3x35x SimpleLink™ Wi-Fi® and Internet-of-Things Design Checklist](#)

User's Guides

[CC3135 and CC3235 SimpleLink™ Wi-Fi®](#)

CC3135 and CC3235 SimpleLink Wi-Fi Embedded Programming User Guide

*Embedded Programming
User Guide*

*UniFlash SimpleLink™
CC31xx/32xx Wi-Fi®
and IoC™ Solution
ImageCreator and Pro*

This document describes the installation, operation, and usage of the SimpleLink ImageCreator tool as part of the UniFlash.

*SimpleLink™ Wi-Fi® and
Internet-of-Things CC31xx
and CC32xx Network
Processor*

This document provides software (SW) programmers with all of the required knowledge for working with the networking subsystem of the SimpleLink Wi-Fi devices. This guide provides basic guidelines for writing robust, optimized networking host applications, and describes the capabilities of the networking subsystem. The guide contains some example code snapshots, to give users an idea of how to work with the host driver. More comprehensive code examples can be found in the formal software development kit (SDK). This guide does not provide a detailed description of the host driver APIs.

*SimpleLink™ Wi-Fi®
CC3135 and CC3235
Provisioning for Mobile
Applications*

This guide describes TI's SimpleLink Wi-Fi provisioning solution for mobile applications, specifically on the usage of the Android™ and IOS® building blocks for UI requirements, networking, and provisioning APIs required for building the mobile application.

*CC3235 SimpleLink™ Wi-
Fi® and Internet of Things
Technical Reference Manual*

This technical reference manual details the modules and peripherals of the CC3235 SimpleLink™ Wi-Fi® MCU. Each description presents the module or peripheral in a general sense. Not all features and functions of all modules or peripherals may be present on all devices. Pin functions, internal signal connections, and operational parameters differ from device to device. The user should consult the device-specific data sheet for these details.

*SimpleLink™ Wi-Fi®
and Internet-on-a chip™
CC3135 and CC3235
Solution Radio Tool*

The Radio Tool serves as a control panel for direct access to the radio, and can be used for both the radio frequency (RF) evaluation and for certification purposes. This guide describes how to have the tool work seamlessly on Texas Instruments evaluation platforms such as the BoosterPack™ plus FTDI emulation board for CC3235 devices, and the LaunchPad™ for CC3235 devices.

*CC3235MOD SimpleLink™
Wi-Fi® LaunchPad™
Development Kit*

The CC3235MOD SimpleLink LaunchPad™ Development Kit (LAUNCHCC3235MOD) is a low-cost evaluation platform for Arm®Cortex®-M4-based MCUs. The LaunchPad design highlights the CC3235MOD Internet-on-a chip™ solution and Dual-Band Wi-Fi capabilities. The CC3235MOD LaunchPad also features temperature and accelerometer sensors, programmable user buttons, an RGB LED for custom applications, and onboard emulation for debugging. The stackable headers of the CC3235MOD LaunchPad XL interface demonstrate how easy it is to expand the functionality of the LaunchPad when interfacing with other peripherals on many existing BoosterPack™ Plug-in Module add-on boards, such as graphical displays, audio codecs, antenna selection, environmental sensing, and more.

11.5 Related Links

The table below lists quick access links. Categories include technical documents, support and community resources, tools and software, and quick access to order now.

Table 11-1. Related Links

PARTS	PRODUCT FOLDER	ORDER NOW	TECHNICAL DOCUMENTS	TOOLS & SOFTWARE	SUPPORT & COMMUNITY
CC3235MODS	Click here	Click here	Click here	Click here	Click here
CC3235MODSF	Click here	Click here	Click here	Click here	Click here
CC3235MODAS	Click here	Click here	Click here	Click here	Click here
CC3235MODASF	Click here	Click here	Click here	Click here	Click here

11.6 Support Resources

[TI E2E™ support forums](#) are an engineer's go-to source for fast, verified answers and design help — straight from the experts. Search existing answers or ask your own question to get the quick design help you need.

Linked content is provided "AS IS" by the respective contributors. They do not constitute TI specifications and do not necessarily reflect TI's views; see TI's [Terms of Use](#).

11.7 Trademarks

WPA™, WPA2™, WPA3™, and Wi-Fi CERTIFIED™ are trademarks of Wi-Fi Alliance.

SimpleLink™, E2E™, BoosterPack™, LaunchPad™, Sitara™, and TI E2E™ are trademarks of Texas Instruments.

Macronix™ is a trademark of Macronix International Co.

Macrocell™ is a trademark of Kappa Global Inc.

Android™ is a trademark of Google LLC.

Wi-Fi Alliance®, Wi-Fi®, and Wi-Fi Direct® are registered trademarks of Wi-Fi Alliance.

Arm®, Cortex®, Thumb® are registered trademarks of Arm Limited.

Bluetooth® is a registered trademark of Bluetooth SIG, Inc.

Zigbee® is a registered trademark of Zigbee Alliance Inc.

IOS® is a registered trademark of Cisco.

All trademarks are the property of their respective owners.

11.8 Electrostatic Discharge Caution



This integrated circuit can be damaged by ESD. Texas Instruments recommends that all integrated circuits be handled with appropriate precautions. Failure to observe proper handling and installation procedures can cause damage.

ESD damage can range from subtle performance degradation to complete device failure. Precision integrated circuits may be more susceptible to damage because very small parametric changes could cause the device not to meet its published specifications.

11.9 Glossary

[TI Glossary](#) This glossary lists and explains terms, acronyms, and definitions.

12 Revision History

Changes from Revision B (May 2021) to Revision C (December 2024)	Page
• Added the note on the TLS socket for WPA Enterprise security modes in Section 8.4.1	66

Changes from August 20, 2020 to May 13, 2021 (from Revision A (Aug 2020) to Revision B (May 2021))	Page
• Added WPA3 Enterprise to Wi-Fi network processor subsystem, Security in Section 1	1
• Changed Figure 4-1	4
• Added WPA3 enterprise to Section 8.4	66
• Added WPA3 Enterprise to Section 8.4.1	66
• Added WPA3 enterprise to Wi-Fi security Feature in Table 8-1	66
• Changed Figure 11-1	98

13 Mechanical, Packaging, and Orderable Information

The following pages include mechanical, packaging, and orderable information. This information is the most current data available for the designated devices. This data is subject to change without notice and revision of this document.

13.1 Mechanical, Land, and Solder Paste Drawings

Note

The total height of the module is 2.4 mm.

The weight of the CC3235MODx module is 1.8g typical.

The weight of the CC3235MODAx module is 1.8g typical.

Note

1. All dimensions are in mm.
 2. Solder mask should be the same or 5% larger than the dimension of the pad.
 3. Solder paste must be the same as the pin for all peripheral pads. For ground pins, make the solder paste 20% smaller than the pad.
-

13.2 Package Option Addendum

The CC3235MODx is only offered in a 750-unit reel. The CC3235MODAx is only offered in a 700-unit reel.

13.2.1 Packaging Information

Orderable Device	Status ⁽¹⁾	Package Type	Package Drawing	Pins	Package Qty	Eco Plan ⁽²⁾	Lead/Ball Finish	MSL, Peak Temp ⁽³⁾	Op Temp (°C)	Device Marking ^{(4) (5)}
CC3235MODSF12MOBR	ACTIVE	QFM	MOB	63	750	Green (RoHS and no Sb/Br)	ENIG	3, 260°C	-40 to 85	CC3235MODSF12MOB
CC3235MODSM2MOBR	ACTIVE	QFM	MOB	63	750	Green (RoHS and no Sb/Br)	ENIG	3, 260°C	-40 to 85	CC3235MODSM2MOB
CC3235MODASF12MONR	PREVIEW	QFM	MON	63	700	Green (RoHS and no Sb/Br)	ENIG	3, 260°C	-40 to 85	CC3235MODASF12MON
CC3235MODASM2MONR	PREVIEW	QFM	MON	63	700	Green (RoHS and no Sb/Br)	ENIG	3, 260°C	-40 to 85	CC3235MODASM2MON

- (1) The marketing status values are defined as follows:
ACTIVE: Product device recommended for new designs.
LIFEBUY: TI has announced that the device will be discontinued, and a lifetime-buy period is in effect.
NRND: Not recommended for new designs. Device is in production to support existing customers, but TI does not recommend using this part in a new design.
PRE_PROD Unannounced device, not in production, not available for mass market, nor on the web, samples not available.
PREVIEW: Device has been announced but is not in production. Samples may or may not be available.
OBSOLETE: TI has discontinued the production of the device.
- (2) Eco Plan - The planned eco-friendly classification: Pb-Free (RoHS), Pb-Free (RoHS Exempt), or Green (RoHS & no Sb/Br) - please check <http://www.ti.com/productcontent> for the latest availability information and additional product content details.
Pb-Free (RoHS): TI's terms "Lead-Free" or "Pb-Free" mean semiconductor products that are compatible with the current RoHS requirements for all 6 substances, including the requirement that lead not exceed 0.1% by weight in homogeneous materials. Where designed to be soldered at high temperatures, TI Pb-Free products are suitable for use in specified lead-free processes.
Pb-Free (RoHS Exempt): This component has a RoHS exemption for either 1) lead-based flip-chip solder bumps used between the die and package, or 2) lead-based die adhesive used between the die and leadframe. The component is otherwise considered Pb-Free (RoHS compatible) as defined above.
Green (RoHS & no Sb/Br): TI defines "Green" to mean Pb-Free (RoHS compatible), and free of Bromine (Br) and Antimony (Sb) based flame retardants (Br or Sb do not exceed 0.1% by weight in homogeneous material)
- (3) MSL, Peak Temp. -- The Moisture Sensitivity Level rating according to the JEDEC industry standard classifications, and peak solder temperature.
- (4) There may be additional marking, which relates to the logo, the lot trace code information, or the environmental category on the device
- (5) Multiple Device markings will be inside parentheses. Only on Device Marking contained in parentheses and separated by a "~" will appear on a device. If a line is indented then it is a continuation of the previous line and the two combined represent the entire Device Marking for that device.
Important Information and Disclaimer: The information provided on this page represents TI's knowledge and belief as of the date that it is provided. TI bases its knowledge and belief on information provided by third parties, and makes no representation or warranty as to the accuracy of such information. Efforts are underway to better integrate information from third parties. TI has taken and continues to take reasonable steps to provide representative and accurate information but may not have conducted destructive testing or chemical analysis on incoming materials and chemicals. TI and TI suppliers consider certain information to be proprietary, and thus CAS numbers and other limited information may not be available for release.
 In no event shall TI's liability arising out of such information exceed the total purchase price of the TI part(s) at issue in this document sold by TI to Customer on an annual basis.

13.2.2 Tape and Reel Information

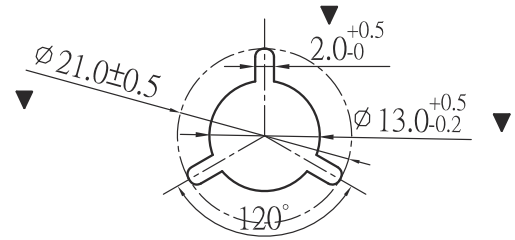
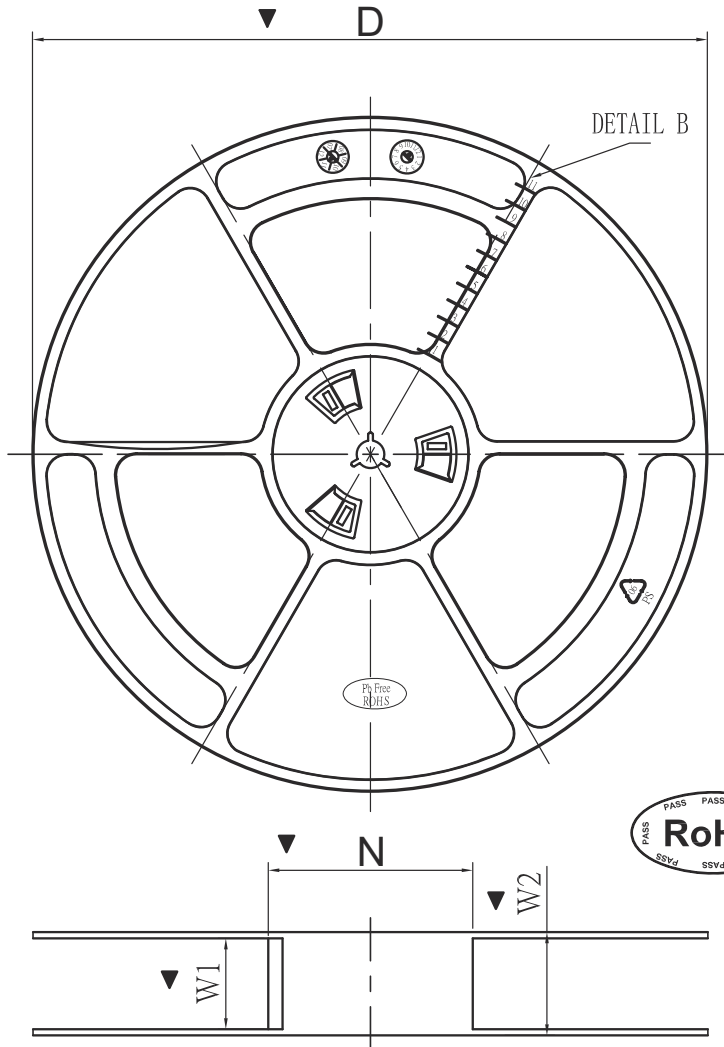

D	330.0 max
N	101±1.0
W1	44±2.0
W2	45.8 max

13.2.3 CC3235MODx Tape Specifications

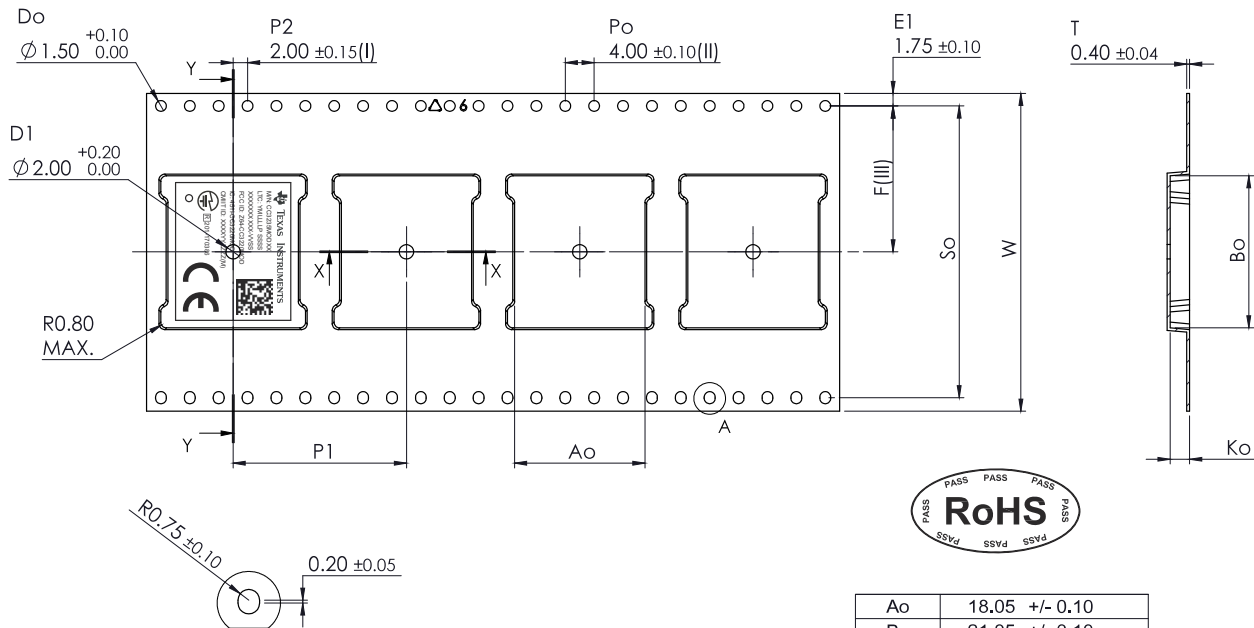

A_o	18.05 +/- 0.10
B_o	21.05 +/- 0.10
K_o	2.70 +/- 0.10
F	20.20 +/- 0.15
P_1	24.00 +/- 0.10
S_o	40.40 +/- 0.10
W	44.00 +/- 0.30

1. 10 sprocket hole pitch cumulative tolerance ± 0.20 .
2. Material: Polystyrene
3. All dimensions meet EIA-481-E requirements.
4. Thickness: 0.2 ± 0.05 mm

13.2.4 CC3235MODAx Tape Specifications

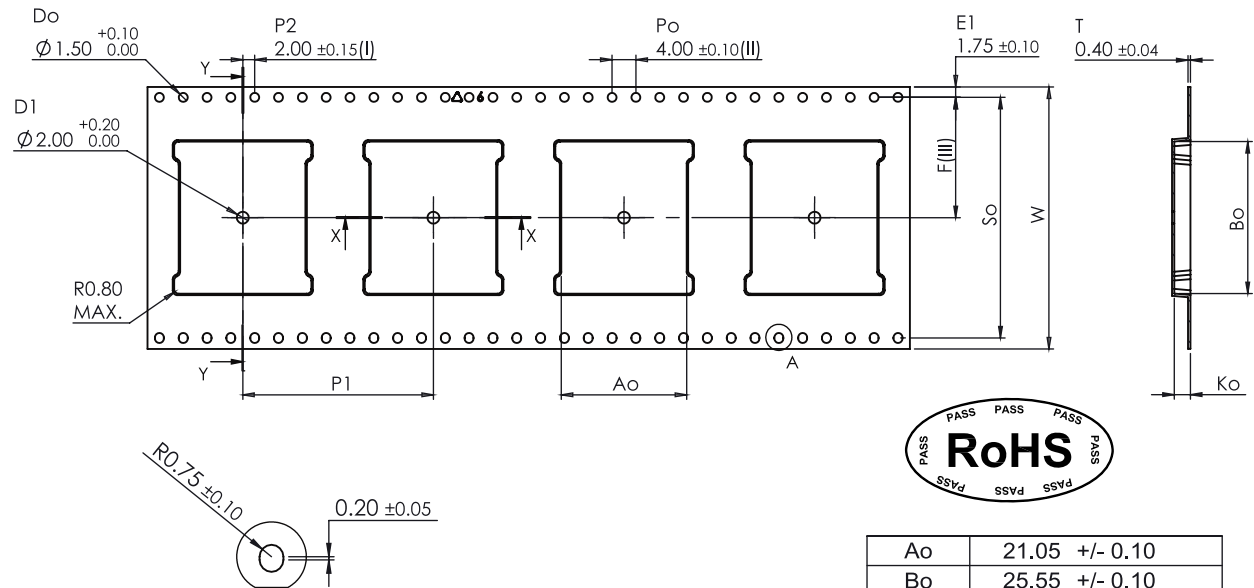

A_o	21.05 +/- 0.10
B_o	25.55 +/- 0.10
K_o	2.70 +/- 0.10
F	20.20 +/- 0.15
P_1	32.00 +/- 0.10
S_o	40.40 +/- 0.10
W	44.00 +/- 0.30

1. 10 sprocket hole pitch cumulative tolerance ± 0.20 .
2. Material: Polystyrene
3. All dimensions meet EIA-481-E requirements.
4. Thickness: 0.2 ± 0.05 mm

PACKAGING INFORMATION

Orderable Device	Status (1)	Package Type	Package Drawing	Pins	Package Qty	Eco Plan (2)	Lead finish/ Ball material (6)	MSL Peak Temp (3)	Op Temp (°C)	Device Marking (4/5)	Samples
CC3235MODASF12MONR	ACTIVE	QFM	MON	63	700	RoHS & Green	NIAU	Level-3-260C-168 HR	-40 to 85	CC3235MODASF12MON Z64-CC3235MOD 4511-CC3235MOD 201-190033 XXXXXXXXXX(M)	Samples
CC3235MODASM2MONR	ACTIVE	QFM	MON	63	700	RoHS & Green	NIAU	Level-3-260C-168 HR	-40 to 85	CC3235MODASM2MON Z64-CC3235MOD 4511-CC3235MOD 201-190033	Samples
CC3235MODSF12MOBR	ACTIVE	QFM	MOB	63	750	RoHS & Green	NIAU	Level-3-260C-168 HR	-40 to 85	CC3235MODSF12MOB Z64-CC3235MOD 4511-CC3235MOD 201-190033	Samples
CC3235MODSM2MOBR	ACTIVE	QFM	MOB	63	750	RoHS & Green	NIAU	Level-3-260C-168 HR	-40 to 85	CC3235MODSM2MOB Z64-CC3235MOD 4511-CC3235MOD 201-190033 E	Samples

(1) The marketing status values are defined as follows:

ACTIVE: Product device recommended for new designs.

LIFEBUY: TI has announced that the device will be discontinued, and a lifetime-buy period is in effect.

NRND: Not recommended for new designs. Device is in production to support existing customers, but TI does not recommend using this part in a new design.

PREVIEW: Device has been announced but is not in production. Samples may or may not be available.

OBSELETE: TI has discontinued the production of the device.

(2) **RoHS:** TI defines "RoHS" to mean semiconductor products that are compliant with the current EU RoHS requirements for all 10 RoHS substances, including the requirement that RoHS substance do not exceed 0.1% by weight in homogeneous materials. Where designed to be soldered at high temperatures, "RoHS" products are suitable for use in specified lead-free processes. TI may reference these types of products as "Pb-Free".

RoHS Exempt: TI defines "RoHS Exempt" to mean products that contain lead but are compliant with EU RoHS pursuant to a specific EU RoHS exemption.

Green: TI defines "Green" to mean the content of Chlorine (Cl) and Bromine (Br) based flame retardants meet JS709B low halogen requirements of <=1000ppm threshold. Antimony trioxide based flame retardants must also meet the <=1000ppm threshold requirement.

(3) MSL, Peak Temp. - The Moisture Sensitivity Level rating according to the JEDEC industry standard classifications, and peak solder temperature.

(4) There may be additional marking, which relates to the logo, the lot trace code information, or the environmental category on the device.

⁽⁵⁾ Multiple Device Markings will be inside parentheses. Only one Device Marking contained in parentheses and separated by a "~" will appear on a device. If a line is indented then it is a continuation of the previous line and the two combined represent the entire Device Marking for that device.

⁽⁶⁾ Lead finish/Ball material - Orderable Devices may have multiple material finish options. Finish options are separated by a vertical ruled line. Lead finish/Ball material values may wrap to two lines if the finish value exceeds the maximum column width.

Important Information and Disclaimer:The information provided on this page represents TI's knowledge and belief as of the date that it is provided. TI bases its knowledge and belief on information provided by third parties, and makes no representation or warranty as to the accuracy of such information. Efforts are underway to better integrate information from third parties. TI has taken and continues to take reasonable steps to provide representative and accurate information but may not have conducted destructive testing or chemical analysis on incoming materials and chemicals. TI and TI suppliers consider certain information to be proprietary, and thus CAS numbers and other limited information may not be available for release.

In no event shall TI's liability arising out of such information exceed the total purchase price of the TI part(s) at issue in this document sold by TI to Customer on an annual basis.

EXAMPLE BOARD LAYOUT

MON0063A

QFM - 2.4 mm max height

QUAD FLAT MODULE

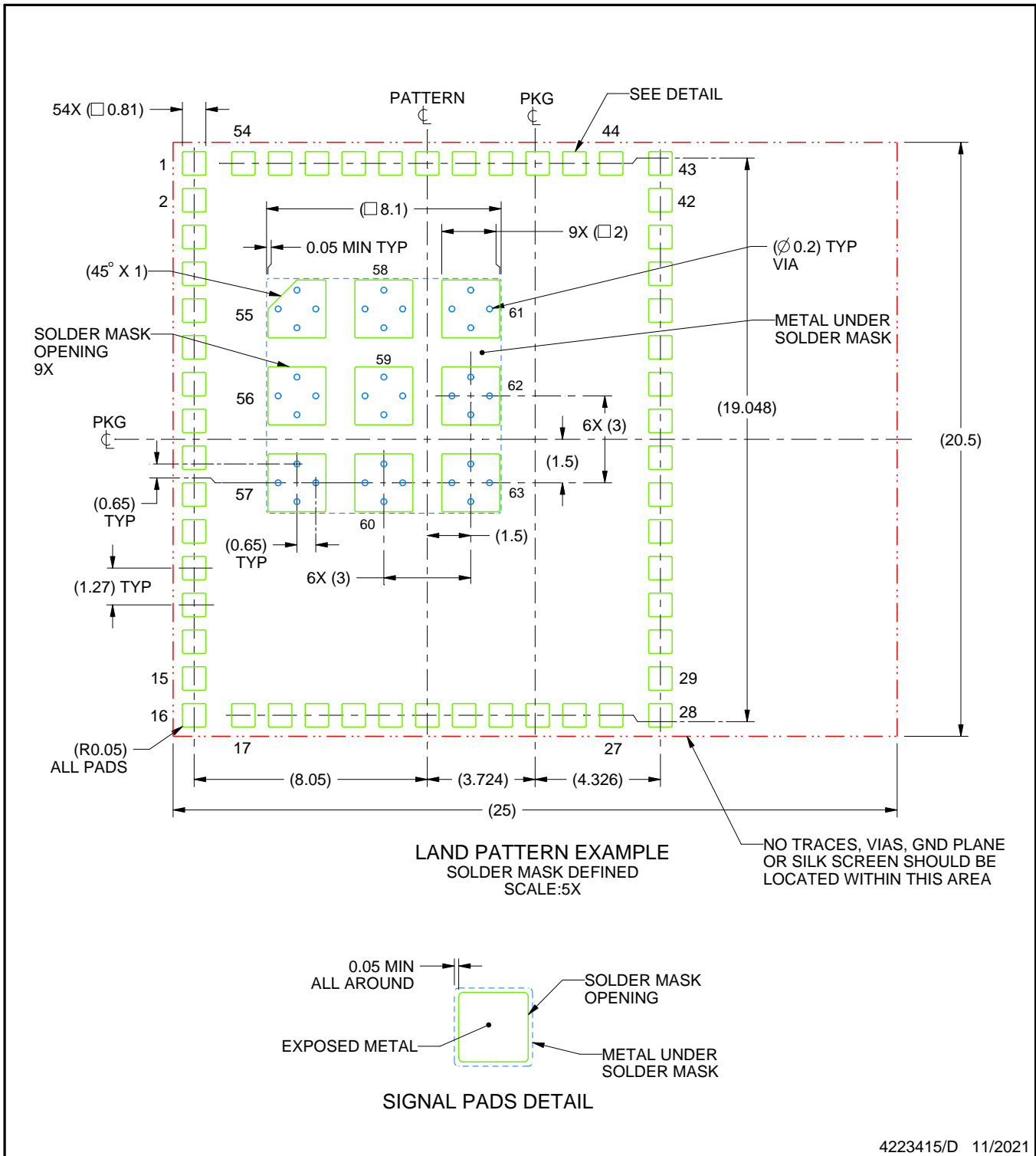

NOTES: (continued)

- This package is designed to be soldered to a thermal pad on the board. For more information, see Texas Instruments literature number SLUA271 (www.ti.com/lit/slua271).
- Vias are optional depending on application, refer to device data sheet. If any vias are implemented, refer to their locations shown on this view. It is recommended that vias under paste be filled, plugged or tented.

EXAMPLE STENCIL DESIGN

MON0063A

QFM - 2.4 mm max height

QUAD FLAT MODULE

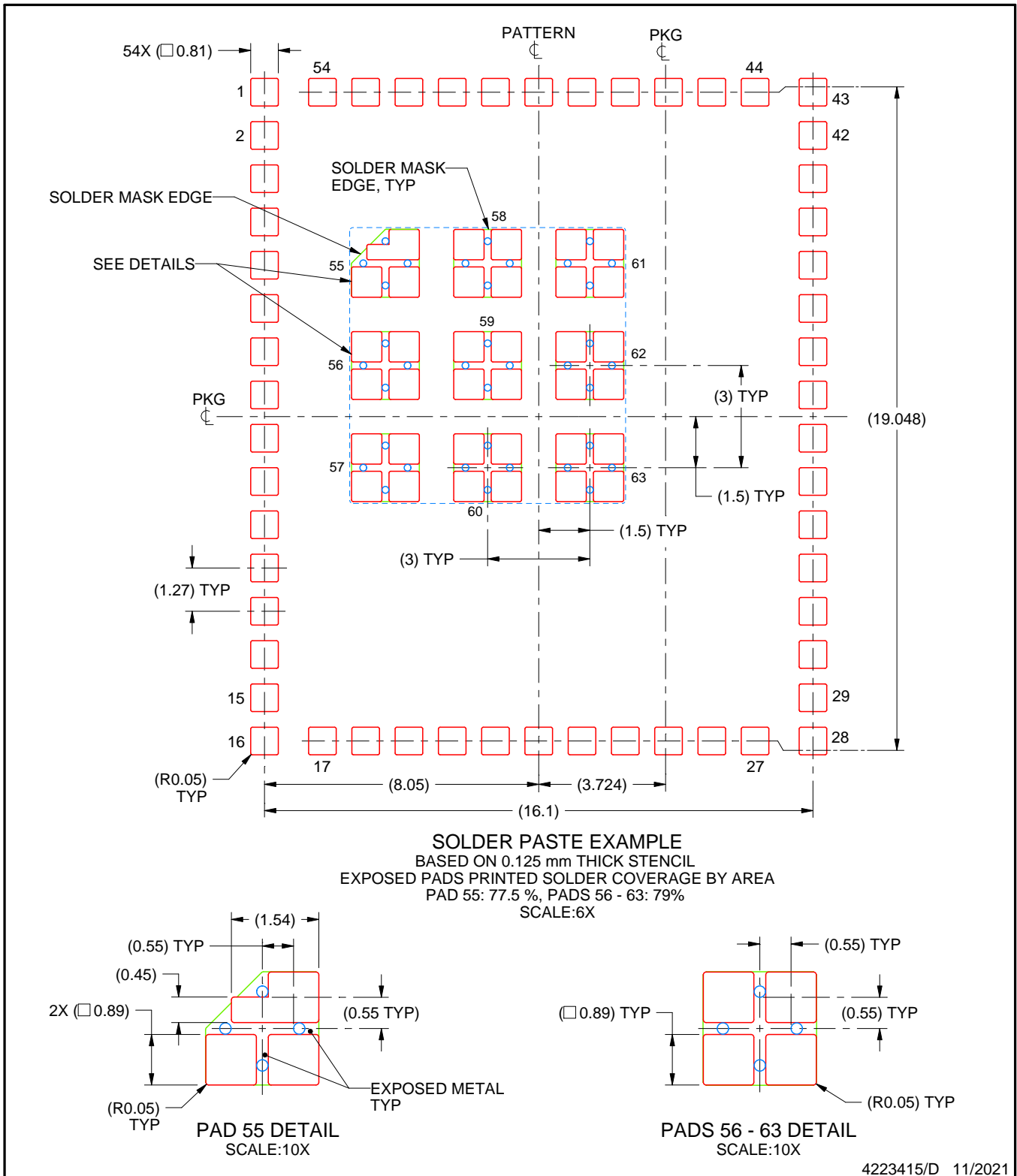

4223415/D 11/2021

NOTES: (continued)

5. Laser cutting apertures with trapezoidal walls and rounded corners may offer better paste release. IPC-7525 may have alternate design recommendations.

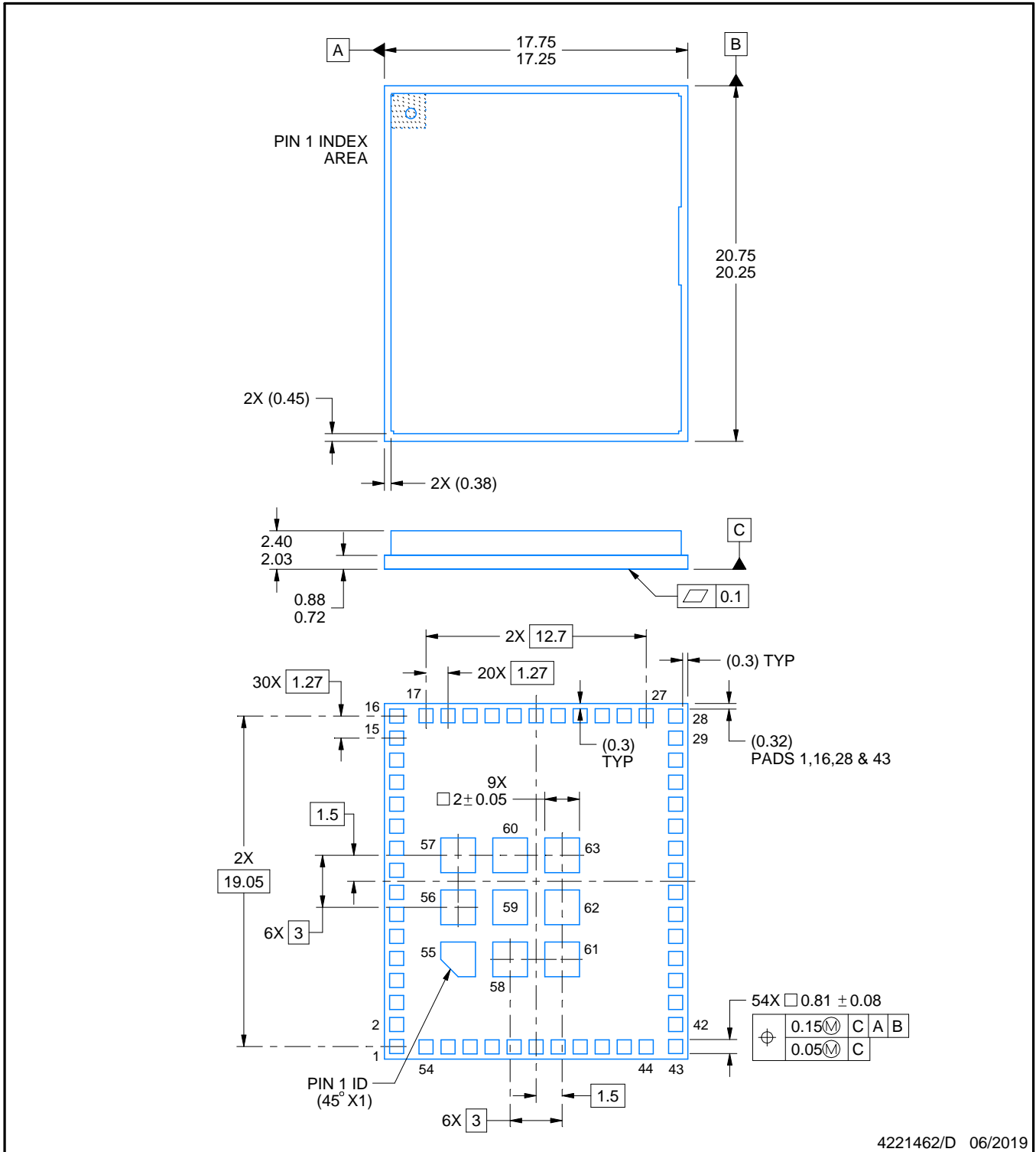

4221462/D 06/2019

NOTES:

1. All linear dimensions are in millimeters. Any dimensions in parenthesis are for reference only. Dimensioning and tolerancing per ASME Y14.5M.
2. This drawing is subject to change without notice.

EXAMPLE BOARD LAYOUT

MOB0063A

QFM - 2.4 mm max height

QUAD FLAT MODULE

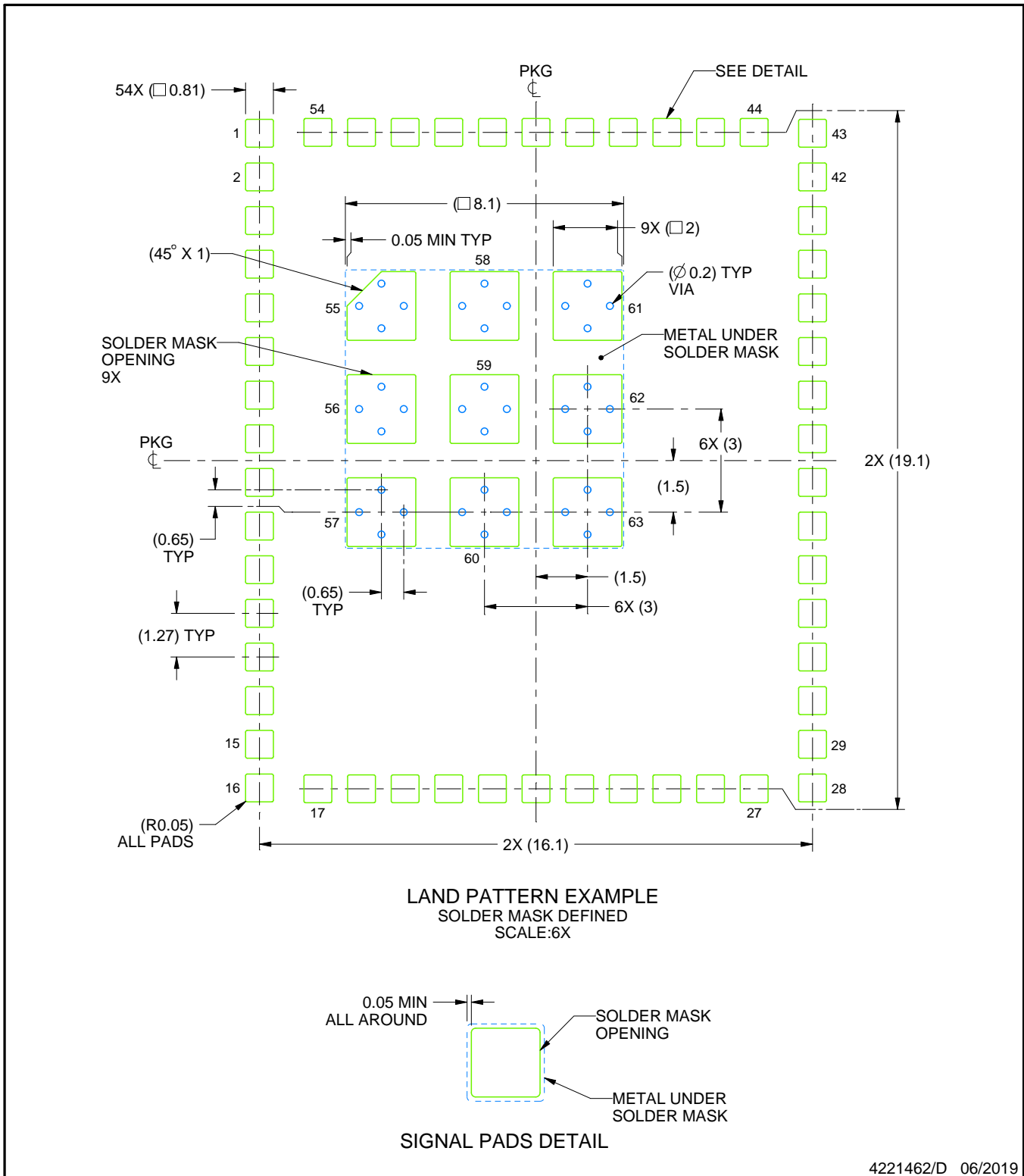

NOTES: (continued)

3. This package is designed to be soldered to a thermal pad on the board. For more information, see Texas Instruments literature number SLUA271 (www.ti.com/lit/slua271).

EXAMPLE STENCIL DESIGN

MOB0063A

QFM - 2.4 mm max height

QUAD FLAT MODULE

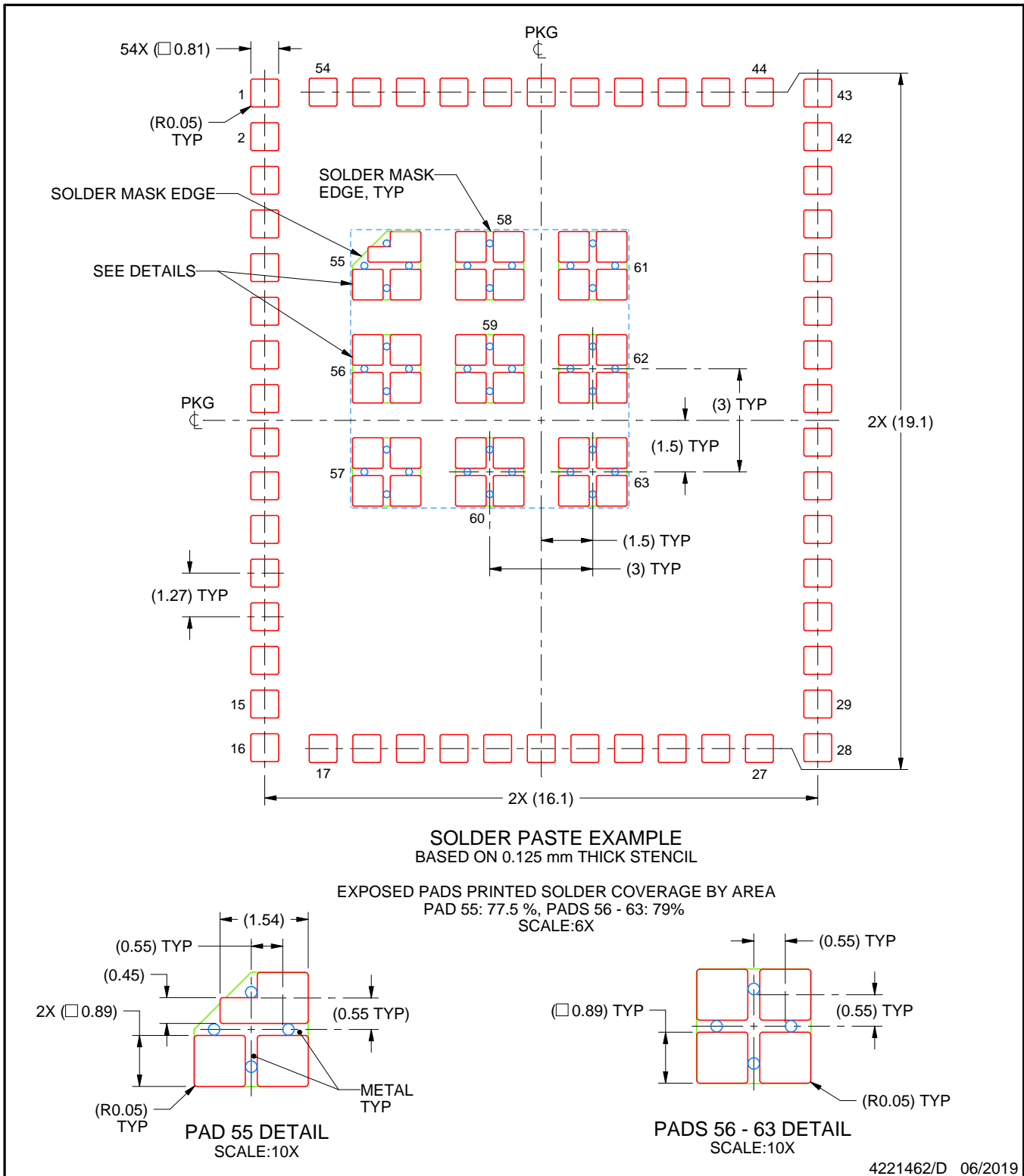

NOTES: (continued)

4. Laser cutting apertures with trapezoidal walls and rounded corners may offer better paste release. IPC-7525 may have alternate design recommendations.

IMPORTANT NOTICE AND DISCLAIMER

TI PROVIDES TECHNICAL AND RELIABILITY DATA (INCLUDING DATA SHEETS), DESIGN RESOURCES (INCLUDING REFERENCE DESIGNS), APPLICATION OR OTHER DESIGN ADVICE, WEB TOOLS, SAFETY INFORMATION, AND OTHER RESOURCES "AS IS" AND WITH ALL FAULTS, AND DISCLAIMS ALL WARRANTIES, EXPRESS AND IMPLIED, INCLUDING WITHOUT LIMITATION ANY IMPLIED WARRANTIES OF MERCHANTABILITY, FITNESS FOR A PARTICULAR PURPOSE OR NON-INFRINGEMENT OF THIRD PARTY INTELLECTUAL PROPERTY RIGHTS.

These resources are intended for skilled developers designing with TI products. You are solely responsible for (1) selecting the appropriate TI products for your application, (2) designing, validating and testing your application, and (3) ensuring your application meets applicable standards, and any other safety, security, regulatory or other requirements.

These resources are subject to change without notice. TI grants you permission to use these resources only for development of an application that uses the TI products described in the resource. Other reproduction and display of these resources is prohibited. No license is granted to any other TI intellectual property right or to any third party intellectual property right. TI disclaims responsibility for, and you will fully indemnify TI and its representatives against, any claims, damages, costs, losses, and liabilities arising out of your use of these resources.

TI's products are provided subject to [TI's Terms of Sale](#) or other applicable terms available either on [ti.com](https://www.ti.com) or provided in conjunction with such TI products. TI's provision of these resources does not expand or otherwise alter TI's applicable warranties or warranty disclaimers for TI products.

TI objects to and rejects any additional or different terms you may have proposed.

Mailing Address: Texas Instruments, Post Office Box 655303, Dallas, Texas 75265
Copyright © 2024, Texas Instruments Incorporated