

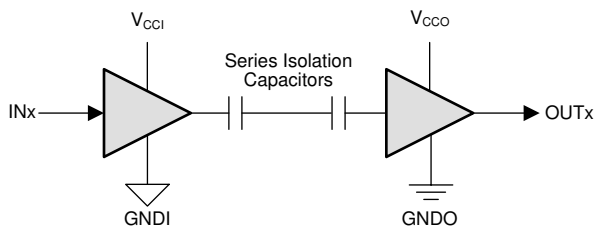
# ISO652x General Purpose Dual-Channel Functional Isolators

## 1 Features

- Dual channel, CMOS output functional isolators
- 50Mbps data rate
- Robust SiO<sub>2</sub> isolation barrier with  $\pm 150\text{kV}/\mu\text{s}$  typical CMTI
- Functional Isolation (8-REU):
  - 200V<sub>RMS</sub>, 280V<sub>DC</sub> working voltage
  - 570V<sub>RMS</sub>, 800V<sub>DC</sub> transient voltage (60s)
- Functional Isolation (8-D):
  - 450V<sub>RMS</sub>, 637V<sub>DC</sub> working voltage
  - 707V<sub>RMS</sub>, 1000V<sub>DC</sub> transient voltage (60s)
- Available in a compact 8-REU package with >2.2mm creepage
- Wide supply range: 1.71V to 1.89V and 2.25V to 5.5V
- 1.71V to 5.5V level translation
- Default output *High* (ISO652x) and *Low* (ISO652xF) Options
- Wide temperature range:  $-40^{\circ}\text{C}$  to  $125^{\circ}\text{C}$
- 1.8mA per channel typical at 1Mbps at 3.3V
- Low propagation delay: 11ns typical at 3.3V
- Robust electromagnetic compatibility (EMC)
  - System-Level ESD, EFT, and surge immunity
  - Ultra-low emissions
- Leadless-DFN (8-REU) package and Narrow-SOIC (8-D) package options

## 2 Applications

- [Power supplies](#)
- [Grid, Electricity meter](#)
- [Motor drives](#)
- [Factory automation](#)
- [Building automation](#)
- [Lighting](#)
- [Appliances](#)



V<sub>CCI</sub>=Input supply, V<sub>CCO</sub>=Output supply  
 GNDI=Input ground, GNDO=Output ground

### Simplified Schematic

## 3 Description

The ISO652x devices are high-performance, dual-channel functional isolators designed for cost sensitive, space constrained applications that require isolation for non-safety applications. The isolation barrier supports a working voltage of 200V<sub>RMS</sub> / 280V<sub>DC</sub> and transient over voltages of 570V<sub>RMS</sub> / 800V<sub>DC</sub>.

The devices provide high electromagnetic immunity and low emissions at low power consumption, while isolating CMOS or LVCMOS digital I/Os. Each isolation channel has a logic input and output buffer separated by TI's double capacitive silicon dioxide (SiO<sub>2</sub>) insulation barrier. ISO6520 has two isolation channels with both channels in the same direction. ISO6521 has two isolation channels with one channel in each direction. In the event of input power or signal loss, the default output is *high* for devices without suffix F and *low* for devices with suffix F. See [Device Functional Modes](#) section for further details.

These devices help prevent noise currents on data buses, such as UART, SPI, RS-485, RS-232, and CAN from damaging sensitive circuitry. Through chip design and layout techniques, the electromagnetic compatibility of the devices have been significantly enhanced to ease system-level ESD and emissions compliance.

### Package Information

PART NUMBER	PACKAGE <sup>(1)</sup>	PACKAGE SIZE <sup>(2)</sup>
ISO6520, ISO6520F	DFN (8-REU)	3.0mm x 2.0mm
ISO6521, ISO6521F		
ISO6520, ISO6520F	D (8)	4.9mm x 6.0mm
ISO6521, ISO6521F		

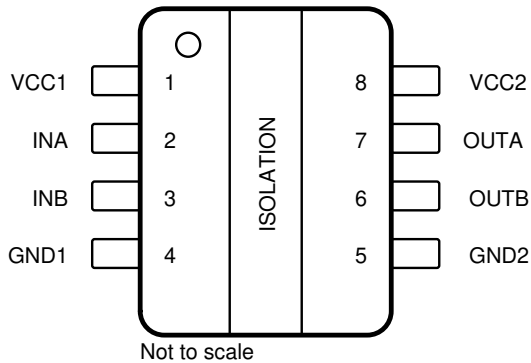
- (1) For all available packages, see the orderable addendum at the end of the data sheet.
- (2) The package size (length × width) is a nominal value and includes pins, where applicable.



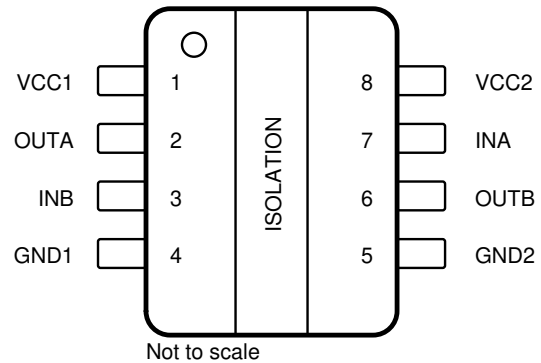
## Table of Contents

<b>1 Features</b> .....	<b>1</b>	<b>6 Parameter Measurement Information</b> .....	<b>14</b>
<b>2 Applications</b> .....	<b>1</b>	<b>7 Detailed Description</b> .....	<b>15</b>
<b>3 Description</b> .....	<b>1</b>	7.1 Overview.....	15
<b>4 Pin Configuration and Functions</b> .....	<b>3</b>	7.2 Functional Block Diagram.....	15
<b>5 Specifications</b> .....	<b>4</b>	7.3 Feature Description.....	16
5.1 Absolute Maximum Ratings.....	4	7.4 Device Functional Modes.....	16
5.2 ESD Ratings.....	4	<b>8 Application and Implementation</b> .....	<b>18</b>
5.3 Recommended Operating Conditions.....	4	8.1 Application Information.....	18
5.4 Thermal Information.....	5	8.2 Typical Application.....	18
5.5 Package Characteristics.....	5	<b>9 Power Supply Recommendations</b> .....	<b>19</b>
5.6 Electrical Characteristics—5-V Supply.....	6	<b>10 Layout</b> .....	<b>19</b>
5.7 Supply Current Characteristics—5-V Supply.....	6	10.1 Layout Guidelines.....	19
5.8 Electrical Characteristics—3.3-V Supply.....	7	10.2 Layout Example.....	20
5.9 Supply Current Characteristics—3.3-V Supply.....	7	<b>11 Device and Documentation Support</b> .....	<b>21</b>
5.10 Electrical Characteristics—2.5-V Supply.....	8	11.1 Documentation Support.....	21
5.11 Supply Current Characteristics—2.5-V Supply.....	8	11.2 Receiving Notification of Documentation Updates..	21
5.12 Electrical Characteristics—1.8-V Supply.....	9	11.3 Support Resources.....	21
5.13 Supply Current Characteristics—1.8-V Supply.....	9	11.4 Trademarks.....	21
5.14 Switching Characteristics—5-V Supply.....	10	11.5 Electrostatic Discharge Caution.....	21
5.15 Switching Characteristics—3.3-V Supply.....	10	11.6 Glossary.....	21
5.16 Switching Characteristics—2.5-V Supply.....	11	<b>12 Revision History</b> .....	<b>21</b>
5.17 Switching Characteristics—1.8-V Supply.....	11	<b>13 Mechanical, Packaging, and Orderable Information</b> .....	<b>22</b>
5.18 Typical Characteristics.....	12		

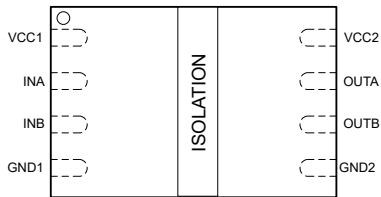
## 4 Pin Configuration and Functions



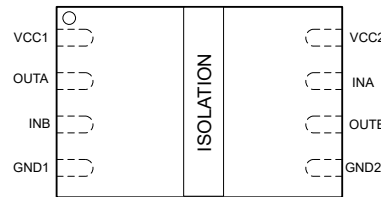
**Figure 4-1. ISO6520 D Package 8-Pin SOIC Top View**



**Figure 4-2. ISO6521 D Package 8-Pin SOIC Top View**



**Figure 4-3. ISO6520 DFN Package 8-Pin REU Top View**



**Figure 4-4. ISO6521 DFN Package 8-Pin REU Top View**

**Table 4-1. Pin Functions**

NAME	PIN		TYPE <sup>(1)</sup>	Description
	ISO6520	ISO6521		
GND1	4	4	-	Ground connection for V <sub>CC1</sub>
GND2	5	5	-	Ground connection for V <sub>CC2</sub>
INA	2	7	I	Input, channel A
INB	3	3	I	Input, channel B
OUTA	7	2	O	Output, channel A
OUTB	6	6	O	Output, channel B
V <sub>CC1</sub>	1	1	P	Power supply, V <sub>CC1</sub>
V <sub>CC2</sub>	8	8	P	Power supply, V <sub>CC2</sub>

(1) I = Input, O = Output, P = Power

## 5 Specifications

### 5.1 Absolute Maximum Ratings

See<sup>(1)</sup>

		MIN	MAX	UNIT
Supply Voltage <sup>(2)</sup>	V <sub>CC1</sub> to GND1	-0.5	6	V
	V <sub>CC2</sub> to GND2	-0.5	6	
Input/Output Voltage	IN <sub>x</sub> to GND <sub>x</sub>	-0.5	V <sub>CCX</sub> + 0.5 <sup>(3)</sup>	V
	OUT <sub>x</sub> to GND <sub>x</sub>	-0.5	V <sub>CCX</sub> + 0.5 <sup>(3)</sup>	
Output Current	I <sub>o</sub>	-15	15	mA
Temperature	Operating junction temperature, T <sub>J</sub>		150	°C
	Storage temperature, T <sub>stg</sub>	-65	150	°C
Transient Isolation Voltage (REU-8)	AC Voltage, t=60s		570	V <sub>RMS</sub>
	DC Voltage, t=60s		800	V <sub>DC</sub>
Transient Isolation Voltage (SOIC-8)	AC Voltage, t=60s		707	V <sub>RMS</sub>
	DC Voltage, t=60s		1000	V <sub>DC</sub>

- Operation outside the Absolute Maximum Ratings may cause permanent device damage. Absolute Maximum Ratings do not imply functional operation of the device at these or any other conditions beyond those listed under Recommended Operating Conditions. If used outside the Recommended Operating Conditions but within the Absolute Maximum Ratings, the device may not be fully functional, and this may affect device reliability, functionality, performance, and shorten the device lifetime.
- All voltage values except differential I/O bus voltages are with respect to the local ground terminal (GND1 or GND2) and are peak voltage values
- Maximum voltage must not exceed 6 V.

### 5.2 ESD Ratings

			VALUE	UNIT
V <sub>(ESD)</sub>	Electrostatic discharge	Human body model (HBM), per ANSI/ESDA/JEDEC JS-001, all pins <sup>(1)</sup>	±6000	V
		Charged device model (CDM), per JEDEC specification JESD22-C101, all pins <sup>(2)</sup>	±1500	

- JEDEC document JEP155 states that 500-V HBM allows safe manufacturing with a standard ESD control process.
- JEDEC document JEP157 states that 250-V CDM allows safe manufacturing with a standard ESD control process.

### 5.3 Recommended Operating Conditions

		TEST CONDITIONS	MIN	NOM	MAX	UNIT
V <sub>CC1</sub> <sup>(1)</sup>	Supply Voltage Side 1	V <sub>CC</sub> = 1.8 V <sup>(3)</sup>	1.71		1.89	V
V <sub>CC1</sub> <sup>(1)</sup>	Supply Voltage Side 1	V <sub>CC</sub> = 2.5 V to 5 V <sup>(3)</sup>	2.25		5.5	V
V <sub>CC2</sub> <sup>(1)</sup>	Supply Voltage Side 2	V <sub>CC</sub> = 1.8 V <sup>(3)</sup>	1.71		1.89	V
V <sub>CC2</sub> <sup>(1)</sup>	Supply Voltage Side 2	V <sub>CC</sub> = 2.5 V to 5 V <sup>(3)</sup>	2.25		5.5	V
V <sub>CC</sub> (UVLO+)	UVLO threshold when supply voltage is rising			1.53	1.71	V
V <sub>CC</sub> (UVLO-)	UVLO threshold when supply voltage is falling		1.1	1.41		V
V <sub>hys</sub> (UVLO)	Supply voltage UVLO hysteresis		0.08	0.13		V
V <sub>IH</sub>	High level Input voltage		0.7 × V <sub>CC1</sub> <sup>(2)</sup>		V <sub>CC1</sub>	V
V <sub>IL</sub>	Low level Input voltage		0		0.3 × V <sub>CC1</sub>	V

		TEST CONDITIONS	MIN	NOM	MAX	UNIT
I <sub>OH</sub>	High level output current	V <sub>CCO</sub> <sup>(2)</sup> = 5 V	-4			mA
		V <sub>CCO</sub> = 3.3 V	-2			mA
		V <sub>CCO</sub> = 2.5 V	-1			mA
		V <sub>CCO</sub> = 1.8 V	-1			mA
I <sub>OL</sub>	Low level output current	V <sub>CCO</sub> = 5 V			4	mA
		V <sub>CCO</sub> = 3.3 V			2	mA
		V <sub>CCO</sub> = 2.5 V			1	mA
		V <sub>CCO</sub> = 1.8 V			1	mA
DR	Data Rate		0		50	Mbps
T <sub>A</sub>	Ambient temperature		-40	25	125	°C
V <sub>IOWM</sub>	Functional Isolation Working Voltage (REU-8)	AC Voltage (sine wave)			200	V <sub>RMS</sub>
		DC Voltage			280	V <sub>DC</sub>
V <sub>IOWM</sub>	Functional Isolation Working Voltage (SOIC-8)	AC Voltage (sine wave)			450	V <sub>RMS</sub>
		DC Voltage			637	V <sub>DC</sub>

- (1) V<sub>CC1</sub> and V<sub>CC2</sub> can be set independent of one another  
(2) V<sub>CC1</sub> = Input-side V<sub>CC</sub>; V<sub>CCO</sub> = Output-side V<sub>CC</sub>  
(3) The channel outputs are in undetermined state when 1.89 V < V<sub>CC1</sub>, V<sub>CC2</sub> < 2.25 V and 1.05 V < V<sub>CC1</sub>, V<sub>CC2</sub> < 1.71 V

## 5.4 Thermal Information

THERMAL METRIC <sup>(1)</sup>		ISO652x		UNIT
		DFN (REU-8)	D (SOIC-8)	
		8 PINS	8 PINS	
R <sub>θJA</sub>	Junction-to-ambient thermal resistance	143.4	104.6	°C/W
R <sub>θJC(top)</sub>	Junction-to-case (top) thermal resistance	70.0	48.9	°C/W
R <sub>θJB</sub>	Junction-to-board thermal resistance	78.3	52.9	°C/W
ψ <sub>JT</sub>	Junction-to-top characterization parameter	4.2	7.9	°C/W
ψ <sub>JB</sub>	Junction-to-board characterization parameter	77.7	52.1	°C/W

- (1) For more information about traditional and new thermal metrics, see the [Semiconductor and IC Package Thermal Metrics](#) application note.

## 5.5 Package Characteristics

PARAMETER		TEST CONDITIONS	VALUE	VALUE	UNIT
			8-REU	8-D	
CLR	External clearance <sup>(1)</sup>	Shortest pin to pin distance through air	>2.2	>4	mm
CPG	External creepage <sup>(1)</sup>	Shortest pin to pin distance across the package surface	>2.2	>4	mm
CTI	Comparative tracking index	IEC 60112; UL 746A	>400	>400	V
	Material Group	According to IEC 60664-1	II	II	
C <sub>IO</sub>	Capacitance, input to output <sup>(2)</sup>	V <sub>IO</sub> = 0.4 × sin (2 πft), f = 1 MHz	≅0.5	≅0.5	pF
R <sub>IO</sub>	Resistance, input to output <sup>(2)</sup>	T <sub>A</sub> = 25°C	>10 <sup>12</sup>	>10 <sup>12</sup>	Ω

- (1) Creepage and clearance requirements must be applied according to the specific equipment isolation standards of an application. Care must be taken to maintain the creepage and clearance distance of a board design to verify that the mounting pads of the isolator on the printed-circuit board do not reduce this distance. Creepage and clearance on a printed-circuit board become equal in certain cases. Techniques such as inserting grooves, ribs, or both on a printed circuit board are used to help increase these specifications.  
(2) All pins on each side of the barrier tied together creating a two-pin device.

## 5.6 Electrical Characteristics—5-V Supply

 $V_{CC1} = V_{CC2} = 5\text{ V} \pm 10\%$  (over recommended operating conditions unless otherwise noted)

PARAMETER		TEST CONDITIONS	MIN	TYP	MAX	UNIT
$V_{OH}$	High-level output voltage	$I_{OH} = -4\text{ mA}$ ; See <a href="#">Figure 6-1</a>	$V_{CCO} - 0.4$			V
$V_{OL}$	Low-level output voltage	$I_{OL} = 4\text{ mA}$ ; See <a href="#">Figure 6-1</a>			0.4	V
$V_{IT+(IN)}$	Rising input switching threshold			$0.7 \times V_{CCI}^{(1)}$		V
$V_{IT-(IN)}$	Falling input switching threshold		$0.3 \times V_{CCI}$			V
$V_{I(HYS)}$	Input threshold voltage hysteresis		$0.1 \times V_{CCI}$			V
$I_{IH}$	High-level input current	$V_{IH} = V_{CCI}^{(1)}$ at INx			10	$\mu\text{A}$
$I_{IL}$	Low-level input current	$V_{IL} = 0\text{ V}$ at INx	-10			$\mu\text{A}$
CMTI	Common mode transient immunity	$V_I = V_{CC}$ or $0\text{ V}$ , $V_{CM} = 700\text{V}$ ; See <a href="#">Figure 6-3</a>	100	150		kV/ $\mu\text{s}$
$C_i$	Input Capacitance <sup>(2)</sup>	$V_I = V_{CC}/2 + 0.4 \times \sin(2\pi ft)$ , $f = 2\text{ MHz}$ , $V_{CC} = 5\text{ V}$		2.8		pF

(1)  $V_{CCI}$  = Input-side  $V_{CC}$ ;  $V_{CCO}$  = Output-side  $V_{CC}$ .

(2) Measured from input pin to same side ground.

## 5.7 Supply Current Characteristics—5-V Supply

 $V_{CC1} = V_{CC2} = 5\text{ V} \pm 10\%$  (over recommended operating conditions unless otherwise noted)

PARAMETER	TEST CONDITIONS	SUPPLY CURRENT	MIN	TYP	MAX	UNIT
<b>ISO6520</b>						
Supply current - DC signal <sup>(2)</sup>	$V_I = V_{CCI}^{(1)}$ (ISO6520), $V_I = 0\text{ V}$ (ISO6520 with F suffix)	$I_{CC1}$		1.1	1.7	mA
		$I_{CC2}$		1.3	2.2	
	$V_I = 0\text{ V}$ (ISO6520), $V_I = V_{CC1}$ (ISO6520 with F suffix)	$I_{CC1}$		3.2	4.6	
		$I_{CC2}$		1.4	2.3	
Supply current - AC signal <sup>(3)</sup>	All channels switching with square wave clock input; $C_L = 15\text{ pF}$	1 Mbps	$I_{CC1}$		2.1	3.1
			$I_{CC2}$		1.5	2.4
		10 Mbps	$I_{CC1}$		2.2	3.2
			$I_{CC2}$		2.7	3.6
		50 Mbps	$I_{CC1}$		2.5	3.6
			$I_{CC2}$		7.9	9.5
<b>ISO6521</b>						
Supply current - DC signal <sup>(2)</sup>	$V_I = V_{CCI}^{(1)}$ (ISO6521); $V_I = 0\text{ V}$ (ISO6521 with F suffix)	$I_{CC1}, I_{CC2}$		1.2	2.2	mA
		$I_{CC1}, I_{CC2}$		2.3	3.5	
Supply current - AC signal <sup>(3)</sup>	All channels switching with square wave clock input; $C_L = 15\text{ pF}$	1 Mbps	$I_{CC1}, I_{CC2}$		1.9	2.9
		10 Mbps	$I_{CC1}, I_{CC2}$		2.5	3.6
		50 Mbps	$I_{CC1}, I_{CC2}$		5.2	6.7

(1)  $V_{CCI}$  = Input-side  $V_{CC}$

(2) Supply current valid for  $ENx = V_{CCx}$  and  $ENx = 0\text{ V}$

(3) Supply current valid for  $ENx = V_{CCx}$

### 5.8 Electrical Characteristics—3.3-V Supply

$V_{CC1} = V_{CC2} = 3.3\text{ V} \pm 10\%$  (over recommended operating conditions unless otherwise noted)

PARAMETER		TEST CONDITIONS	MIN	TYP	MAX	UNIT
$V_{OH}$	High-level output voltage	$I_{OH} = -2\text{mA}$ ; See <a href="#">Figure 6-1</a>	$V_{CCO} - 0.2$			V
$V_{OL}$	Low-level output voltage	$I_{OL} = 2\text{mA}$ ; See <a href="#">Figure 6-1</a>			0.2	V
$V_{IT+(IN)}$	Rising input switching threshold			$0.7 \times V_{CCI}^{(1)}$		V
$V_{IT-(IN)}$	Falling input switching threshold		$0.3 \times V_{CCI}$			V
$V_{I(HYS)}$	Input threshold voltage hysteresis		$0.1 \times V_{CCI}$			V
$I_{IH}$	High-level input current	$V_{IH} = V_{CCI}^{(1)}$ at INx			10	$\mu\text{A}$
$I_{IL}$	Low-level input current	$V_{IL} = 0\text{ V}$ at INx	-10			$\mu\text{A}$
CMTI	Common mode transient immunity	$V_I = V_{CC}$ or 0 V, $V_{CM} = 700\text{V}$ ; See <a href="#">Figure 6-3</a>	100	150		kV/ $\mu\text{s}$
$C_i$	Input Capacitance <sup>(2)</sup>	$V_I = V_{CC}/2 + 0.4 \times \sin(2\pi ft)$ , $f = 2\text{ MHz}$ , $V_{CC} = 3.3\text{ V}$		2.8		pF

- (1)  $V_{CCI}$  = Input-side  $V_{CC}$ ;  $V_{CCO}$  = Output-side  $V_{CC}$ .  
(2) Measured from input pin to same side ground.

### 5.9 Supply Current Characteristics—3.3-V Supply

$V_{CC1} = V_{CC2} = 3.3\text{ V} \pm 10\%$  (over recommended operating conditions unless otherwise noted)

PARAMETER	TEST CONDITIONS		SUPPLY CURRENT	MIN	TYP	MAX	UNIT
<b>ISO6520</b>							
Supply current - DC signal <sup>(2)</sup>	$V_I = V_{CCI}^{(1)}$ (ISO6520), $V_I = 0\text{ V}$ (ISO6520 with F suffix)		$I_{CC1}$		1.1	1.6	mA
			$I_{CC2}$		1.3	2.2	
	$V_I = 0\text{ V}$ (ISO6520), $V_I = V_{CC1}$ (ISO6520 with F suffix)		$I_{CC1}$		3.2	4.5	
			$I_{CC2}$		1.4	2.3	
Supply current - AC signal <sup>(3)</sup>	All channels switching with square wave clock input; $C_L = 15\text{ pF}$	1 Mbps	$I_{CC1}$		2.1	3.1	
			$I_{CC2}$		1.4	2.3	
		10 Mbps	$I_{CC1}$		2.2	3.1	
			$I_{CC2}$		2.3	3.2	
		50 Mbps	$I_{CC1}$		2.4	3.4	
			$I_{CC2}$		6	7.3	
<b>ISO6521</b>							
Supply current - DC signal <sup>(2)</sup>	$V_I = V_{CCI}^{(1)}$ (ISO6521); $V_I = 0\text{ V}$ (ISO6521 with F suffix)		$I_{CC1}, I_{CC2}$		1.2	2.2	mA
		$V_I = 0\text{ V}$ (ISO6521); $V_I = V_{CCI}$ (ISO6521 with F suffix)	$I_{CC1}, I_{CC2}$		2.3	3.5	
Supply current - AC signal <sup>(3)</sup>	All channels switching with square wave clock input; $C_L = 15\text{ pF}$	1 Mbps	$I_{CC1}, I_{CC2}$		1.8	2.9	
		10 Mbps	$I_{CC1}, I_{CC2}$		2.3	3.4	
		50 Mbps	$I_{CC1}, I_{CC2}$		4.2	5.5	

- (1)  $V_{CCI}$  = Input-side  $V_{CC}$   
(2) Supply current valid for  $ENx = V_{CCx}$  and  $ENx = 0\text{V}$   
(3) Supply current valid for  $ENx = V_{CCx}$

## 5.10 Electrical Characteristics—2.5-V Supply

$V_{CC1} = V_{CC2} = 2.5\text{ V} \pm 10\%$  (over recommended operating conditions unless otherwise noted)

PARAMETER		TEST CONDITIONS	MIN	TYP	MAX	UNIT
$V_{OH}$	High-level output voltage	$I_{OH} = -1\text{ mA}$ ; See <a href="#">Figure 6-1</a>	$V_{CCO} - 0.1$			V
$V_{OL}$	Low-level output voltage	$I_{OL} = 1\text{ mA}$ ; See <a href="#">Figure 6-1</a>			0.1	V
$V_{IT+(IN)}$	Rising input switching threshold			$0.7 \times V_{CCI}^{(1)}$		V
$V_{IT-(IN)}$	Falling input switching threshold		$0.3 \times V_{CCI}$			V
$V_{I(HYS)}$	Input threshold voltage hysteresis		$0.1 \times V_{CCI}$			V
$I_{IH}$	High-level input current	$V_{IH} = V_{CCI}^{(1)}$ at INx			10	$\mu\text{A}$
$I_{IL}$	Low-level input current	$V_{IL} = 0\text{ V}$ at INx	-10			$\mu\text{A}$
CMTI	Common mode transient immunity	$V_I = V_{CC}$ or $0\text{ V}$ , $V_{CM} = 700\text{ V}$ ; See <a href="#">Figure 6-3</a>	100	150		kV/ $\mu\text{s}$
$C_i$	Input Capacitance <sup>(2)</sup>	$V_I = V_{CC}/2 + 0.4 \times \sin(2\pi f t)$ , $f = 2\text{ MHz}$ , $V_{CC} = 2.5\text{ V}$		2.8		pF

(1)  $V_{CCI}$  = Input-side  $V_{CC}$ ;  $V_{CCO}$  = Output-side  $V_{CC}$ .

(2) Measured from input pin to same side ground.

## 5.11 Supply Current Characteristics—2.5-V Supply

$V_{CC1} = V_{CC2} = 2.5\text{ V} \pm 10\%$  (over recommended operating conditions unless otherwise noted)

PARAMETER	TEST CONDITIONS		SUPPLY CURRENT	MIN	TYP	MAX	UNIT
<b>ISO6520</b>							
Supply current - DC signal <sup>(2)</sup>	$V_I = V_{CCI}^{(1)}$ (ISO6520), $V_I = 0\text{ V}$ (ISO6520 with F suffix)		$I_{CC1}$		1.1	1.6	mA
			$I_{CC2}$		1.3	2.1	
	$V_I = 0\text{ V}$ (ISO6520), $V_I = V_{CCI}$ (ISO6520 with F suffix)		$I_{CC1}$		3.1	4.5	
			$I_{CC2}$		1.4	2.3	
Supply current - AC signal <sup>(3)</sup>	All channels switching with square wave clock input; $C_L = 15\text{ pF}$	1 Mbps	$I_{CC1}$		2.1	3.1	
			$I_{CC2}$		1.4	2.3	
		10 Mbps	$I_{CC1}$		2.1	3.1	
			$I_{CC2}$		2	2.9	
		50 Mbps	$I_{CC1}$		2.3	3.3	
			$I_{CC2}$		4.8	6	
<b>ISO6521</b>							
Supply current - DC signal <sup>(2)</sup>	$V_I = V_{CCI}^{(1)}$ (ISO6521); $V_I = 0\text{ V}$ (ISO6521 with F suffix)		$I_{CC1}, I_{CC2}$		1.2	2.2	mA
		$V_I = 0\text{ V}$ (ISO6521); $V_I = V_{CCI}$ (ISO6521 with F suffix)	$I_{CC1}, I_{CC2}$		2.3	3.5	
Supply current - AC signal <sup>(3)</sup>	All channels switching with square wave clock input; $C_L = 15\text{ pF}$	1 Mbps	$I_{CC1}, I_{CC2}$		1.8	2.9	
		10 Mbps	$I_{CC1}, I_{CC2}$		2.1	3.2	
		50 Mbps	$I_{CC1}, I_{CC2}$		3.6	4.9	

(1)  $V_{CCI}$  = Input-side  $V_{CC}$

(2) Supply current valid for  $ENx = V_{CCx}$  and  $ENx = 0\text{ V}$

(3) Supply current valid for  $ENx = V_{CCx}$



## 5.12 Electrical Characteristics—1.8-V Supply

$V_{CC1} = V_{CC2} = 1.8\text{ V} \pm 5\%$  (over recommended operating conditions unless otherwise noted)

PARAMETER		TEST CONDITIONS	MIN	TYP	MAX	UNIT
$V_{OH}$	High-level output voltage	$I_{OH} = -1\text{ mA}$ ; See <a href="#">Figure 6-1</a>	$V_{CCO} - 0.1$			V
$V_{OL}$	Low-level output voltage	$I_{OL} = 1\text{ mA}$ ; See <a href="#">Figure 6-1</a>			0.1	V
$V_{IT+(IN)}$	Rising input switching threshold			$0.7 \times V_{CCI}^{(1)}$		V
$V_{IT-(IN)}$	Falling input switching threshold		$0.3 \times V_{CCI}$			V
$V_{I(HYS)}$	Input threshold voltage hysteresis		$0.1 \times V_{CCI}$			V
$I_{IH}$	High-level input current	$V_{IH} = V_{CCI}^{(1)}$ at INx			10	$\mu\text{A}$
$I_{IL}$	Low-level input current	$V_{IL} = 0\text{ V}$ at INx	-10			$\mu\text{A}$
CMTI	Common mode transient immunity	$V_I = V_{CC}$ or $0\text{ V}$ , $V_{CM} = 700\text{ V}$ ; See <a href="#">Figure 6-3</a>	100	150		$\text{kV}/\mu\text{s}$
$C_i$	Input Capacitance <sup>(2)</sup>	$V_I = V_{CC}/2 + 0.4 \times \sin(2\pi ft)$ , $f = 2\text{ MHz}$ , $V_{CC} = 1.8\text{ V}$		2.8		pF

(1)  $V_{CCI}$  = Input-side  $V_{CC}$ ;  $V_{CCO}$  = Output-side  $V_{CC}$ .

(2) Measured from input pin to same side ground.

## 5.13 Supply Current Characteristics—1.8-V Supply

$V_{CC1} = V_{CC2} = 1.8\text{ V} \pm 5\%$  (over recommended operating conditions unless otherwise noted)

PARAMETER	TEST CONDITIONS	SUPPLY CURRENT	MIN	TYP	MAX	UNIT	
<b>ISO6520</b>							
Supply current - DC signal <sup>(2)</sup>	$V_I = V_{CCI}^{(1)}$ (ISO6520), $V_I = 0\text{ V}$ (ISO6520 with F suffix)	$I_{CC1}$		0.8	1.5	mA	
		$I_{CC2}$		1.2	2.1		
	$V_I = 0\text{ V}$ (ISO6520), $V_I = V_{CC1}$ (ISO6520 with F suffix)	$I_{CC1}$		2.8	4.3		
		$I_{CC2}$		1.3	2.3		
Supply current - AC signal <sup>(3)</sup>	All channels switching with square wave clock input; $C_L = 15\text{ pF}$	1 Mbps	$I_{CC1}$		1.8		2.9
			$I_{CC2}$		1.3		2.3
		10 Mbps	$I_{CC1}$		1.8		2.9
			$I_{CC2}$		1.8		2.7
		50 Mbps	$I_{CC1}$		2	3.1	
			$I_{CC2}$		3.8	4.9	
<b>ISO6521</b>							
Supply current - DC signal <sup>(2)</sup>	$V_I = V_{CCI}^{(1)}$ (ISO6521); $V_I = 0\text{ V}$ (ISO6521 with F suffix)	$I_{CC1}, I_{CC2}$		1.1	2.1	mA	
		$I_{CC1}, I_{CC2}$		2.1	3.4		
Supply current - AC signal <sup>(3)</sup>	All channels switching with square wave clock input; $C_L = 15\text{ pF}$	1 Mbps	$I_{CC1}, I_{CC2}$		1.6		2.7
			10 Mbps	$I_{CC1}, I_{CC2}$			1.9
		50 Mbps	$I_{CC1}, I_{CC2}$		3		4.2

(1)  $V_{CCI}$  = Input-side  $V_{CC}$

(2) Supply current valid for  $ENx = V_{CCx}$  and  $ENx = 0\text{ V}$

(3) Supply current valid for  $ENx = V_{CCx}$

## 5.14 Switching Characteristics—5-V Supply

 $V_{CC1} = V_{CC2} = 5\text{ V} \pm 10\%$  (over recommended operating conditions unless otherwise noted)

PARAMETER		TEST CONDITIONS	MIN	TYP	MAX	UNIT
$t_{PLH}, t_{PHL}$	Propagation delay time	See <a href="#">Figure 6-1</a>		11	18	ns
$t_{P(dft)}$	Propagation delay drift			8		ps/°C
$t_{UI}$	Minimum pulse width	See <a href="#">Figure 6-1</a>	20			ns
PWD	Pulse width distortion <sup>(1)</sup> $ t_{PHL} - t_{PLH} $	See <a href="#">Figure 6-1</a>		0.2	7	ns
$t_{sk(o)}$	Channel-to-channel output skew time <sup>(2)</sup>	Same direction channels			6	ns
$t_{sk(p-p)}$	Part-to-part skew time <sup>(3)</sup>				6	ns
$t_r$	Output signal rise time	See <a href="#">Figure 6-1</a>		2.6	4.5	ns
$t_f$	Output signal fall time			2.6	4.5	ns
$t_{PU}$	Time from UVLO to valid output data				300	μs
$t_{DO}$	Default output delay time from input power loss	Measured from the time $V_{CC}$ goes below 1.2V. See <a href="#">Figure 6-2</a>		0.1	0.3	μs
$t_{ie}$	Time interval error	$2^{16} - 1$ PRBS data at 50 Mbps		1		ns

(1) Also known as pulse skew.

(2)  $t_{sk(o)}$  is the skew between outputs of a single device with all driving inputs connected together and the outputs switching in the same direction while driving identical loads.

(3)  $t_{sk(pp)}$  is the magnitude of the difference in propagation delay times between any terminals of different devices switching in the same direction while operating at identical supply voltages, temperature, input signals and loads.

## 5.15 Switching Characteristics—3.3-V Supply

 $V_{CC1} = V_{CC2} = 3.3\text{ V} \pm 10\%$  (over recommended operating conditions unless otherwise noted)

PARAMETER		TEST CONDITIONS	MIN	TYP	MAX	UNIT
$t_{PLH}, t_{PHL}$	Propagation delay time	See <a href="#">Figure 6-1</a>		11	18	ns
$t_{P(dft)}$	Propagation delay drift			9.2		ps/°C
$t_{UI}$	Minimum pulse width	See <a href="#">Figure 6-1</a>	20			ns
PWD	Pulse width distortion <sup>(1)</sup> $ t_{PHL} - t_{PLH} $	See <a href="#">Figure 6-1</a>		0.5	7	ns
$t_{sk(o)}$	Channel-to-channel output skew time <sup>(2)</sup>	Same direction channels			6	ns
$t_{sk(p-p)}$	Part-to-part skew time <sup>(3)</sup>				6	ns
$t_r$	Output signal rise time	See <a href="#">Figure 6-1</a>		1.6	3.2	ns
$t_f$	Output signal fall time			1.6	3.2	ns
$t_{PU}$	Time from UVLO to valid output data				300	μs
$t_{DO}$	Default output delay time from input power loss	Measured from the time $V_{CC}$ goes below 1.2V. See <a href="#">Figure 6-2</a>		0.1	0.3	μs
$t_{ie}$	Time interval error	$2^{16} - 1$ PRBS data at 50 Mbps		1		ns

(1) Also known as pulse skew.

(2)  $t_{sk(o)}$  is the skew between outputs of a single device with all driving inputs connected together and the outputs switching in the same direction while driving identical loads.

(3)  $t_{sk(pp)}$  is the magnitude of the difference in propagation delay times between any terminals of different devices switching in the same direction while operating at identical supply voltages, temperature, input signals and loads.

## 5.16 Switching Characteristics—2.5-V Supply

$V_{CC1} = V_{CC2} = 2.5\text{ V} \pm 10\%$  (over recommended operating conditions unless otherwise noted)

PARAMETER		TEST CONDITIONS	MIN	TYP	MAX	UNIT
$t_{PLH}, t_{PHL}$	Propagation delay time	See <a href="#">Figure 6-1</a>		12	20.5	ns
$t_{P(dft)}$	Propagation delay drift			14.3		ps/°C
$t_{UI}$	Minimum pulse width	See <a href="#">Figure 6-1</a>	20			ns
PWD	Pulse width distortion <sup>(1)</sup> $ t_{PHL} - t_{PLH} $	See <a href="#">Figure 6-1</a>		0.6	7.1	ns
$t_{sk(o)}$	Channel-to-channel output skew time <sup>(2)</sup>	Same direction channels			6	ns
$t_{sk(p-p)}$	Part-to-part skew time <sup>(3)</sup>				6.1	ns
$t_r$	Output signal rise time	See <a href="#">Figure 6-1</a>		2	4	ns
$t_f$	Output signal fall time			2	4	ns
$t_{PU}$	Time from UVLO to valid output data				300	μs
$t_{DO}$	Default output delay time from input power loss	Measured from the time $V_{CC}$ goes below 1.2V. See <a href="#">Figure 6-2</a>		0.1	0.3	μs
$t_{ie}$	Time interval error	$2^{16} - 1$ PRBS data at 50 Mbps		1		ns

(1) Also known as pulse skew.

(2)  $t_{sk(o)}$  is the skew between outputs of a single device with all driving inputs connected together and the outputs switching in the same direction while driving identical loads.

(3)  $t_{sk(pp)}$  is the magnitude of the difference in propagation delay times between any terminals of different devices switching in the same direction while operating at identical supply voltages, temperature, input signals and loads.

## 5.17 Switching Characteristics—1.8-V Supply

$V_{CC1} = V_{CC2} = 1.8\text{ V} \pm 5\%$  (over recommended operating conditions unless otherwise noted)

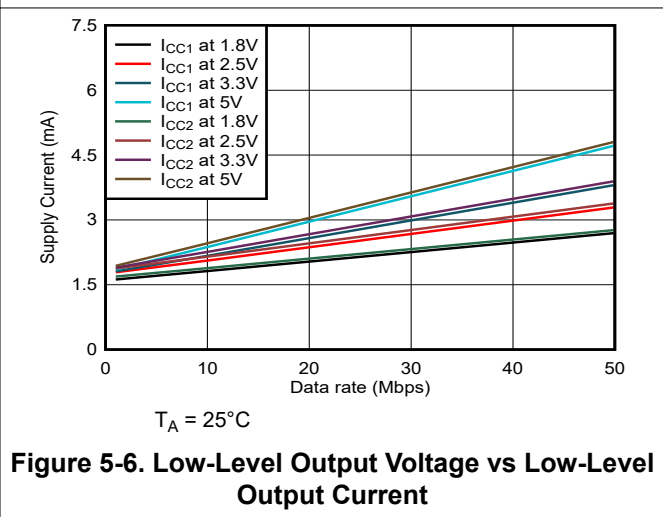
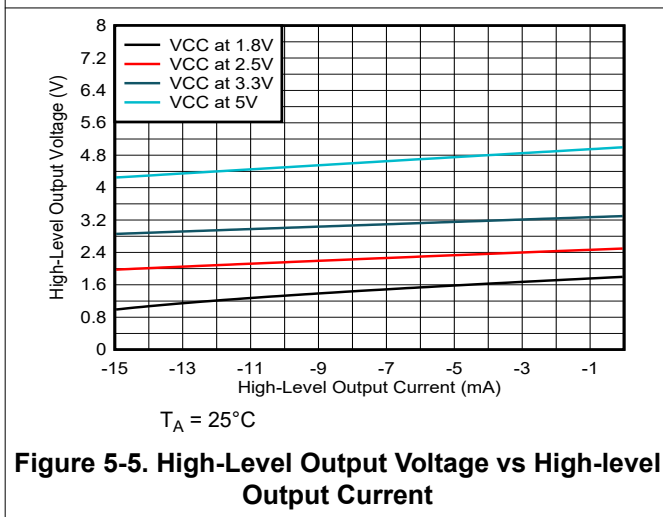
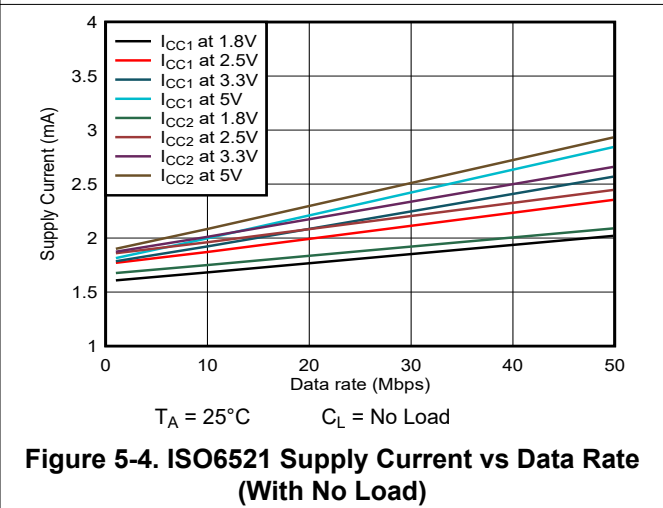
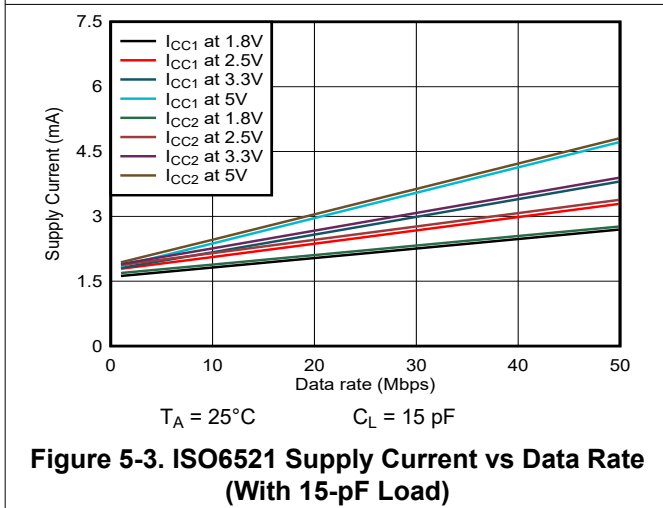
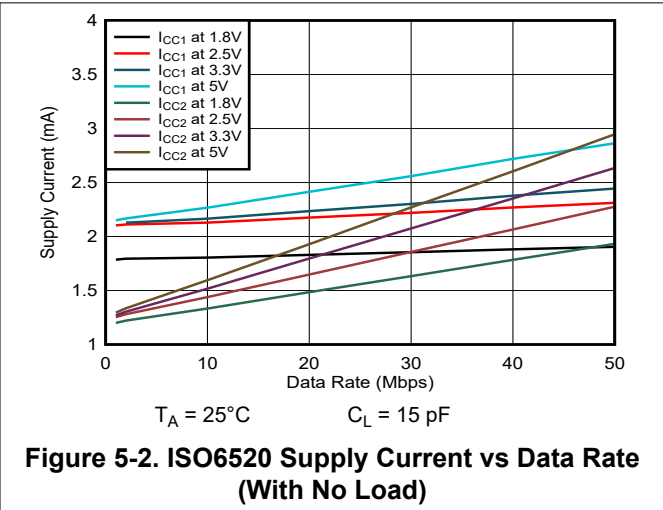
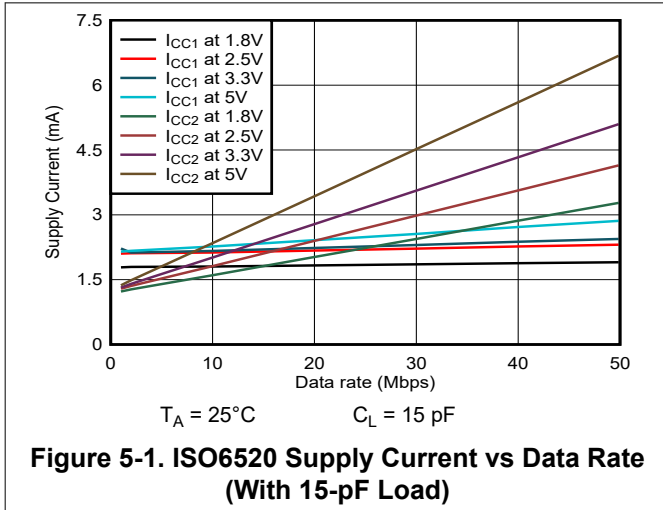
PARAMETER		TEST CONDITIONS	MIN	TYP	MAX	UNIT
$t_{PLH}, t_{PHL}$	Propagation delay time	See <a href="#">Figure 7-1</a>		15	25.1	ns
$t_{P(dft)}$	Propagation delay drift			15.2		ps/°C
$t_{UI}$	Minimum pulse width	See <a href="#">Figure 7-1</a>	20			ns
PWD	Pulse width distortion <sup>(1)</sup> $ t_{PHL} - t_{PLH} $	See <a href="#">Figure 7-1</a>		0.7	8.2	ns
$t_{sk(o)}$	Channel-to-channel output skew time <sup>(2)</sup>	Same direction channels			6	ns
$t_{sk(p-p)}$	Part-to-part skew time <sup>(3)</sup>				8.8	ns
$t_r$	Output signal rise time	See <a href="#">Figure 7-1</a>		2.7	5.3	ns
$t_f$	Output signal fall time			2.7	5.3	ns
$t_{PU}$	Time from UVLO to valid output data				300	μs
$t_{DO}$	Default output delay time from input power loss	Measured from the time $V_{CC}$ goes below 1.2V. See <a href="#">Figure 6-2</a>		0.1	0.3	μs
$t_{ie}$	Time interval error	$2^{16} - 1$ PRBS data at 50 Mbps		1		ns

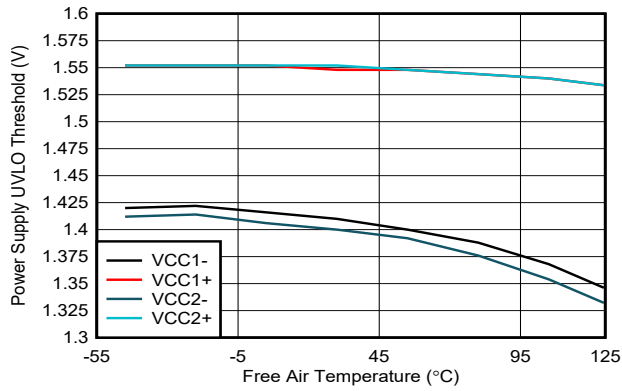
(1) Also known as pulse skew.

(2)  $t_{sk(o)}$  is the skew between outputs of a single device with all driving inputs connected together and the outputs switching in the same direction while driving identical loads.

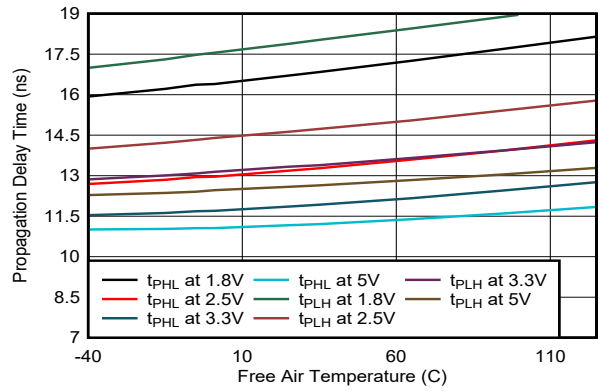
(3)  $t_{sk(pp)}$  is the magnitude of the difference in propagation delay times between any terminals of different devices switching in the same direction while operating at identical supply voltages, temperature, input signals and loads.

### 5.18 Typical Characteristics



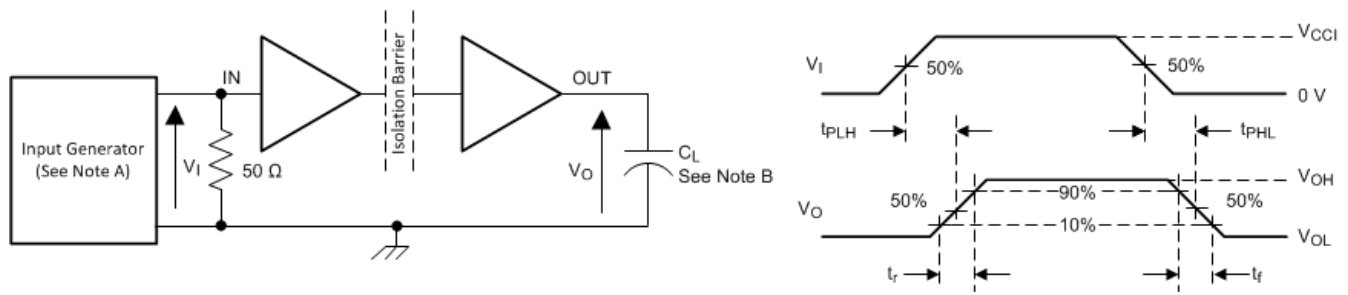


**Figure 5-7. Power Supply Undervoltage Threshold vs Free-Air Temperature**



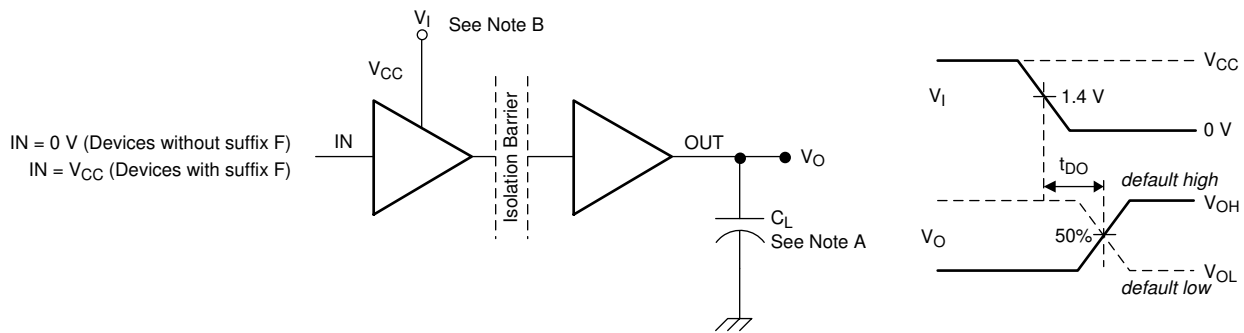
**Figure 5-8. Propagation Delay Time vs Free-Air Temperature**

## 6 Parameter Measurement Information



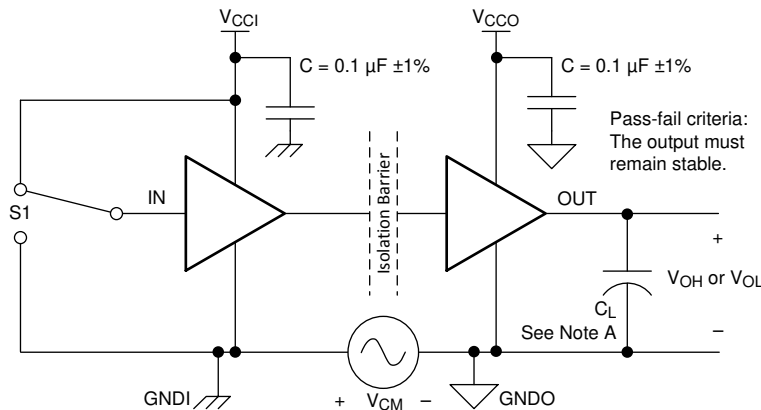
- A. The input pulse is supplied by a generator having the following characteristics: PRR  $\leq$  50 kHz, 50% duty cycle,  $t_r \leq$  3 ns,  $t_f \leq$  3 ns,  $Z_O = 50 \Omega$ . At the input, 50  $\Omega$  resistor is required to terminate Input Generator signal. The 50  $\Omega$  resistor is not needed in the actual application.
- B.  $C_L = 15$  pF and includes instrumentation and fixture capacitance within  $\pm 20\%$ .

**Figure 6-1. Switching Characteristics Test Circuit and Voltage Waveforms**



- A.  $C_L = 15$  pF and includes instrumentation and fixture capacitance within  $\pm 20\%$ .
- B. Power Supply Ramp Rate = 10 mV/ns

**Figure 6-2. Default Output Delay Time Test Circuit and Voltage Waveforms**



- A.  $C_L = 15$  pF and includes instrumentation and fixture capacitance within  $\pm 20\%$ .

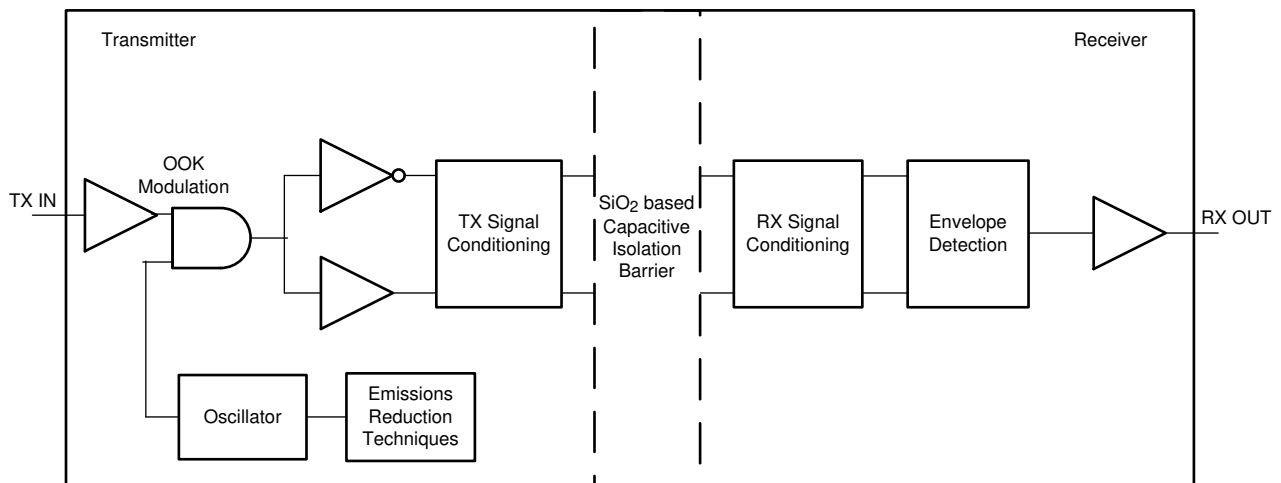
**Figure 6-3. Common-Mode Transient Immunity Test Circuit**

## 7 Detailed Description

### 7.1 Overview

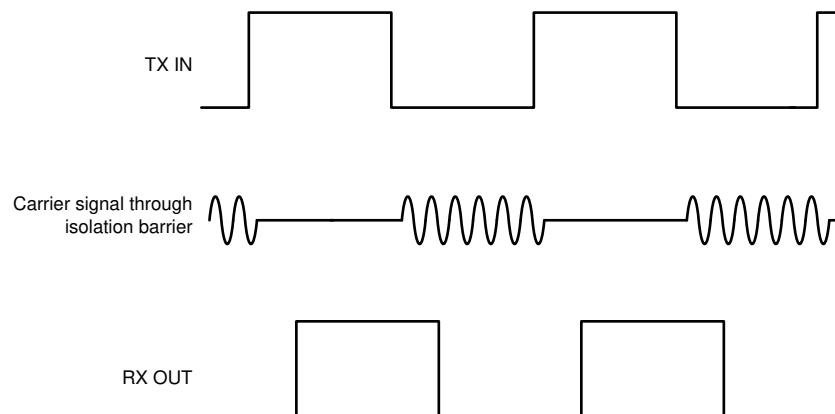
The ISO652x family of devices has an ON-OFF keying (OOK) modulation scheme to transmit the digital data across a silicon dioxide based isolation barrier. The transmitter sends a high frequency carrier across the barrier to represent one digital state and sends no signal to represent the other digital state. The receiver demodulates the signal after advanced signal conditioning and produces the output through a buffer stage. These devices also incorporate advanced circuit techniques to maximize the CMTI performance and minimize the radiated emissions due the high frequency carrier and IO buffer switching. The conceptual block diagram of a digital capacitive isolator, [Figure 7-1](#), shows a functional block diagram of a typical channel.

### 7.2 Functional Block Diagram



**Figure 7-1. Conceptual Block Diagram of a Digital Capacitive Isolator**

[Figure 7-2](#) shows a conceptual detail of how the OOK scheme works.



**Figure 7-2. On-Off Keying (OOK) Based Modulation Scheme**

## 7.3 Feature Description

family of devices is available in two channel configurations and default output state options to enable a variety of application uses. lists the device features of the devices.

**Table 7-1. Device Features**

PART NUMBER	MAXIMUM DATA RATE	CHANNEL DIRECTION	DEFAULT OUTPUT STATE	PACKAGE
ISO6520	50 Mbps	2 Forward, 0 Reverse	High	REU-8
ISO6520F	50 Mbps	2 Forward, 0 Reverse	Low	REU-8
ISO6521	50 Mbps	1 Forward, 1 Reverse	High	REU-8
ISO6521F	50 Mbps	1 Forward, 1 Reverse	Low	REU-8

## 7.4 Device Functional Modes

Table 7-2 lists the functional modes for the devices.

**Table 7-2. Function Table**

V <sub>CCI</sub> <sup>(1)</sup>	V <sub>CCO</sub>	INPUT (IN <sub>x</sub> ) <sup>(2)</sup>	OUTPUT (OUT <sub>x</sub> )	COMMENTS
PU	PU	H	H	Normal Operation: A channel output assumes the logic state of the input.
		L	L	
		Open	Default	Default mode: When IN <sub>x</sub> is open, the corresponding channel output goes to the default logic state. The default is <i>High</i> for and <i>Low</i> for with F suffix.
PD	PU	X	Default	Default mode: When V <sub>CCI</sub> is unpowered, a channel output assumes the logic state based on the selected default option. The default is <i>High</i> for and <i>Low</i> for with F suffix. When V <sub>CCI</sub> transitions from unpowered to powered-up, a channel output assumes the logic state of the input. When V <sub>CCI</sub> transitions from powered-up to unpowered, channel output assumes the selected default state.
X	PD	X	Undetermined	When V <sub>CCO</sub> is unpowered, a channel output is undetermined <sup>(3)</sup> . When V <sub>CCO</sub> transitions from unpowered to powered-up, a channel output assumes the logic state of the input

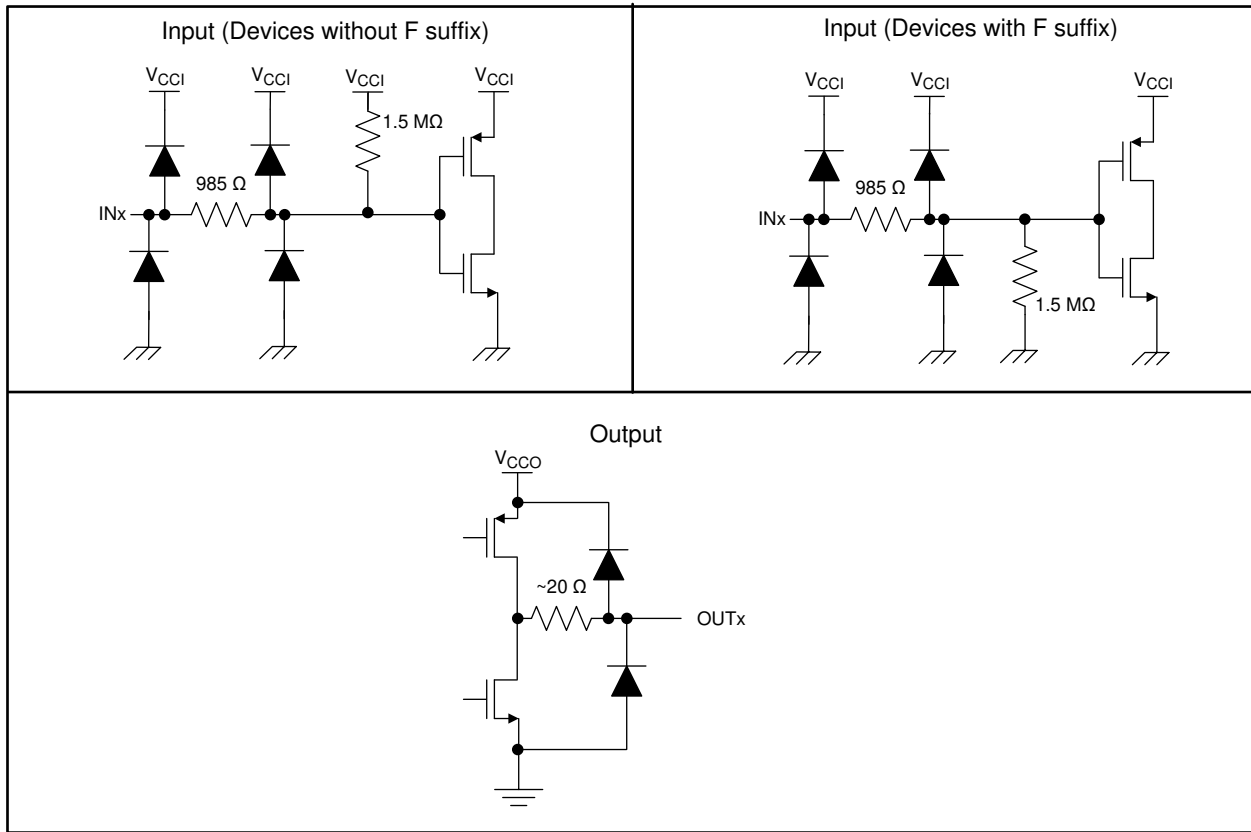
(1) V<sub>CCI</sub> = Input-side V<sub>CC</sub>; V<sub>CCO</sub> = Output-side V<sub>CC</sub>; PU = Powered up (V<sub>CC</sub> ≥ 1.71V); PD = Powered down (V<sub>CC</sub> ≤ 1.05 V); X = Irrelevant; H = High level; L = Low level

(2) A strongly driven input signal can weakly power the floating V<sub>CC</sub> via an internal protection diode and cause undetermined output.

(3) The outputs are in undetermined state when 1.89 V < V<sub>CCI</sub>, V<sub>CCO</sub> < 2.25 V and 1.05 V < V<sub>CCI</sub>, V<sub>CCO</sub> < 1.71 V



### 7.4.1 Device I/O Schematics



**Figure 7-3. Device I/O Schematics**

## 8 Application and Implementation

### Note

Information in the following applications sections is not part of the TI component specification, and TI does not warrant the accuracy or completeness. TI's customers are responsible for determining suitability of components for their purposes. Customers should validate and test their design implementation to confirm system functionality.

### 8.1 Application Information

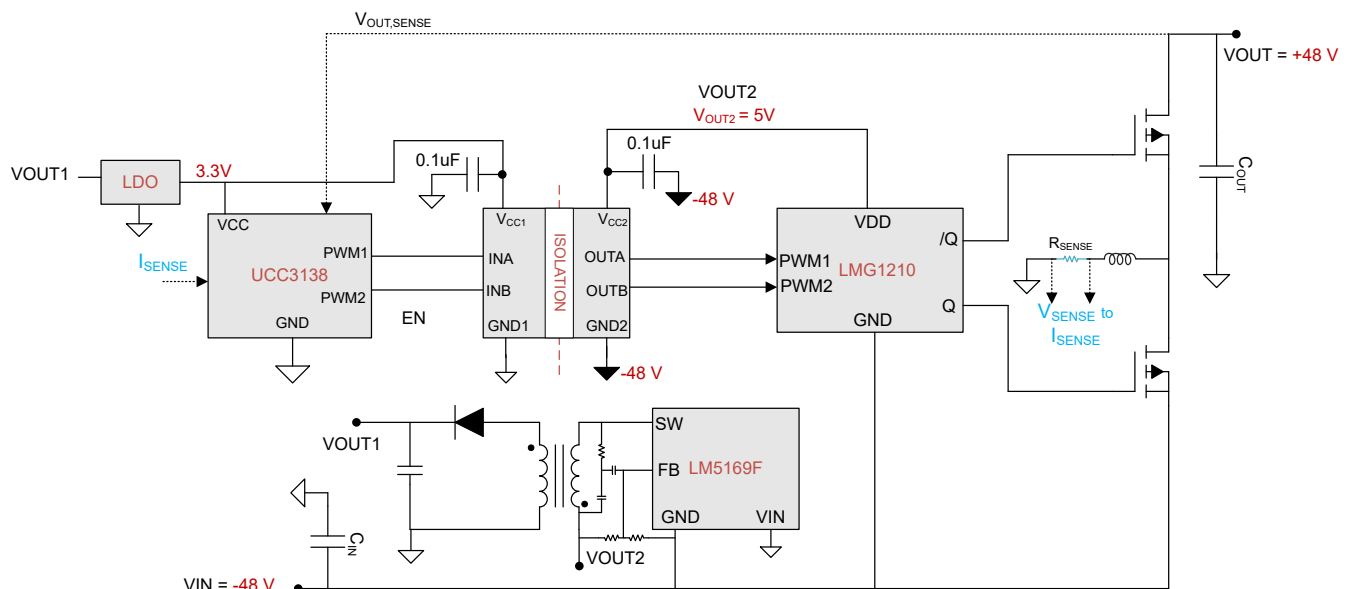
The ISO652x devices are high-performance, dual-channel digital isolators. The devices use single-ended CMOS-logic switching technology. The supply voltage range is from 1.71 V to 5.5 V for both supplies,  $V_{CC1}$  and  $V_{CC2}$ . Since an isolation barrier separates the two sides, each side can be sourced independently with any voltage within the recommended operating conditions. As an example, supplying  $V_{CC1}$  with 3.3 V (which is within 1.71 V to 1.89 V and 2.25 V to 5 V) and  $V_{CC2}$  with 5 V (which is also within 1.71 V to 1.89 V and 2.25 V to 5 V) is possible. The digital isolator can be used as a logic-level translator in addition to providing isolation. When designing with digital isolators, keep in mind that because of the single-ended design structure, digital isolators do not conform to any specific interface standard and are only intended for isolating single-ended CMOS or TTL digital signal lines. The isolator is typically placed between the data controller (that is, MCU or FPGA), and a data converter or a line transceiver, regardless of the interface type or standard.

### Note

ISO652x is a functional isolator, and is not certified for isolation by standard bodies. For applications that require certified isolation by standard bodies, customers must choose [ISO672x](#), [ISO772x](#) or [ISO782x](#) families of digital isolators.

### 8.2 Typical Application

ISO652x can be used with Texas Instruments' mixed signal microcontroller, voltage regulator and GaN with integrated drivers in several power supply designs. ISO652x helps isolate high voltage power MOSFETs from sensitive logic control circuitry.



**Figure 8-1. ISO6520 for Level shifting PWM signals from controller referenced to Ground to the FET driver in an Inverted Buck Boost Topology**

## 8.2.1 Design Requirements

To design with these devices, use the parameters listed in [Table 8-1](#).

**Table 8-1. Design Parameters**

PARAMETER	VALUE
Supply voltage, $V_{CC1}$ and $V_{CC2}$	1.71 V to 1.89 V and 2.25 V to 5.5 V
Decoupling capacitor between $V_{CC1}$ and GND1	0.1 $\mu$ F
Decoupling capacitor from $V_{CC2}$ and GND2	0.1 $\mu$ F

## 9 Power Supply Recommendations

To provide reliable operation at data rates and supply voltages, a 0.1- $\mu$ F bypass capacitor is recommended at the input and output supply pins ( $V_{CC1}$  and  $V_{CC2}$ ). The capacitors must be placed as close to the supply pins as possible. If only a single primary-side power supply is available in an application, isolated power can be generated for the secondary-side with the help of a transformer driver. For industrial applications, please use Texas Instruments' [SN6501](#) or [SN6505B](#). For such applications, detailed power supply design and transformer selection recommendations are available in [SN6501 Transformer Drivers for Isolated Power Supplies](#) or [SN6505B-Q1 Low-noise, 1-A Transformer Drivers for Isolated Power Supplies](#).

## 10 Layout

### 10.1 Layout Guidelines

A minimum of two layers is required to accomplish a cost optimized and low EMI PCB design. To further improve EMI, a four layer board can be used. Layer stacking for a four layer board must be in the following order (top-to-bottom): high-speed signal layer, ground plane, power plane and low-frequency signal layer.

- Routing the high-speed traces on the top layer avoids the use of vias (and the introduction of the inductances) and allows for clean interconnects between the isolator and the transmitter and receiver circuits of the data link.
- Placing a solid ground plane next to the high-speed signal layer establishes controlled impedance for transmission line interconnects and provides an excellent low-inductance path for the return current flow.
- Placing the power plane next to the ground plane creates additional high-frequency bypass capacitance of approximately 100 pF/in<sup>2</sup>.
- Routing the slower speed control signals on the bottom layer allows for greater flexibility as these signal links usually have margin to tolerate discontinuities such as vias.
- Bypass the VCC pin to ground with a low-ESR ceramic bypass capacitor. The typical recommended bypass capacitance is 0.1  $\mu$ F when using a ceramic capacitor with an X5R- or X7R-rated dielectric. The capacitor must be placed as close to the VCC pin as possible in the PCB layout and on the same layer. The capacitor must have a voltage rating greater than the VCC voltage level.

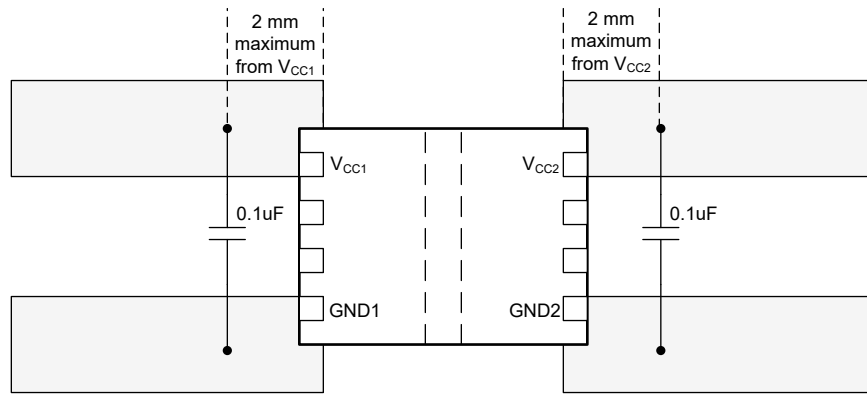
If an additional supply voltage plane or signal layer is needed, add a second power or ground plane system to the stack to keep the planes symmetrical. This design makes the stack mechanically stable and prevents warping. Also the power and ground plane of each power system can be placed closer together, thus increasing the high-frequency bypass capacitance significantly.

For detailed layout recommendations, refer to the [Digital Isolator Design Guide](#).

#### 10.1.1 PCB Material

For digital circuit boards operating at less than 150 Mbps, (or rise and fall times greater than 1 ns), and trace lengths of up to 10 inches, use standard FR-4 UL94V-0 printed circuit board. This PCB is preferred over cheaper alternatives because of lower dielectric losses at high frequencies, less moisture absorption, greater strength and stiffness, and the self-extinguishing flammability-characteristics.

## 10.2 Layout Example



Solid ground islands help  
dissipate heat through PCB

**Figure 10-1. Layout Example**

## 11 Device and Documentation Support

### 11.1 Documentation Support

#### 11.1.1 Related Documentation

For related documentation, see the following:

- Texas Instruments, [Isolation Glossary](#), application note
- Texas Instruments, [SN6501 Transformer Driver for Isolated Power Supplies](#), data sheet
- Texas Instruments, [SN6505x Low-Noise 1-A Transformer Drivers for Isolated Power Supplies](#), data sheet
- Texas Instruments, [SN6507 Low-Emissions, 36-V Push-Pull Transformer Driver with Duty Cycle Control for Isolated Power Supplies](#), data sheet
- Texas Instruments, [LMG341xR070 600-V 70-mΩ GaN with Integrated Driver and Protection](#), data sheet

#### 11.2 Receiving Notification of Documentation Updates

To receive notification of documentation updates, navigate to the device product folder on ti.com. In the upper right corner, click on *Alert me* to register and receive a weekly digest of any product information that has changed. For change details, review the revision history included in any revised document.

#### 11.3 Support Resources

[TI E2E™ support forums](#) are an engineer's go-to source for fast, verified answers and design help — straight from the experts. Search existing answers or ask your own question to get the quick design help you need.

Linked content is provided "AS IS" by the respective contributors. They do not constitute TI specifications and do not necessarily reflect TI's views; see TI's [Terms of Use](#).

#### 11.4 Trademarks

TI E2E™ is a trademark of Texas Instruments.  
All trademarks are the property of their respective owners.

#### 11.5 Electrostatic Discharge Caution



This integrated circuit can be damaged by ESD. Texas Instruments recommends that all integrated circuits be handled with appropriate precautions. Failure to observe proper handling and installation procedures can cause damage.

ESD damage can range from subtle performance degradation to complete device failure. Precision integrated circuits may be more susceptible to damage because very small parametric changes could cause the device not to meet its published specifications.

#### 11.6 Glossary

[TI Glossary](#) This glossary lists and explains terms, acronyms, and definitions.

## 12 Revision History

NOTE: Page numbers for previous revisions may differ from page numbers in the current version.

### Changes from Revision A (December 2023) to Revision B (April 2024) Page

- |  |   |
|--|---|
| • Updated the number formatting for tables, figures, and cross-references throughout the document..... | 1 |
| • Added information about the ISO6521F variant throughout the document .....                           | 1 |

### Changes from Revision \* (August 2023) to Revision A (December 2023) Page

- |   |    |
|---|----|
| • Updated device status to Production Data..... | 1  |
| • Updated Typical Application Diagram.....      | 18 |

## 13 Mechanical, Packaging, and Orderable Information

The following pages include mechanical packaging and orderable information. This information is the most current data available for the designated devices. This data is subject to change without notice and revision of this document. For browser-based versions of this data sheet, refer to the left-hand navigation.

**PACKAGING INFORMATION**

Orderable Device	Status (1)	Package Type	Package Drawing	Pins	Package Qty	Eco Plan (2)	Lead finish/ Ball material (6)	MSL Peak Temp (3)	Op Temp (°C)	Device Marking (4/5)	Samples
ISO6520DR	ACTIVE	SOIC	D	8	3000	RoHS & Green	NIPDAU	Level-2-260C-1 YEAR	-40 to 125	6520	Samples
ISO6520FDR	ACTIVE	SOIC	D	8	3000	RoHS & Green	NIPDAU	Level-2-260C-1 YEAR	-40 to 125	6520F	Samples
ISO6520FREUR	ACTIVE	VSON	REU	8	3000	RoHS & Green	NIPDAU	Level-2-260C-1 YEAR	-40 to 125	6520F	Samples
ISO6520REUR	ACTIVE	VSON	REU	8	3000	RoHS & Green	NIPDAU	Level-2-260C-1 YEAR	-40 to 125	6520	Samples
ISO6521DR	ACTIVE	SOIC	D	8	3000	RoHS & Green	NIPDAU	Level-2-260C-1 YEAR	-40 to 125	6521	Samples
ISO6521FDR	ACTIVE	SOIC	D	8	3000	RoHS & Green	NIPDAU	Level-2-260C-1 YEAR	-40 to 125	6521F	Samples
ISO6521FREUR	ACTIVE	VSON	REU	8	3000	RoHS & Green	NIPDAU	Level-2-260C-1 YEAR	-40 to 125	6521F	Samples
ISO6521REUR	ACTIVE	VSON	REU	8	3000	RoHS & Green	NIPDAU	Level-2-260C-1 YEAR	-40 to 125	6521	Samples

(1) The marketing status values are defined as follows:

**ACTIVE:** Product device recommended for new designs.

**LIFEBUY:** TI has announced that the device will be discontinued, and a lifetime-buy period is in effect.

**NRND:** Not recommended for new designs. Device is in production to support existing customers, but TI does not recommend using this part in a new design.

**PREVIEW:** Device has been announced but is not in production. Samples may or may not be available.

**OBSOLETE:** TI has discontinued the production of the device.

(2) **RoHS:** TI defines "RoHS" to mean semiconductor products that are compliant with the current EU RoHS requirements for all 10 RoHS substances, including the requirement that RoHS substance do not exceed 0.1% by weight in homogeneous materials. Where designed to be soldered at high temperatures, "RoHS" products are suitable for use in specified lead-free processes. TI may reference these types of products as "Pb-Free".

**RoHS Exempt:** TI defines "RoHS Exempt" to mean products that contain lead but are compliant with EU RoHS pursuant to a specific EU RoHS exemption.

**Green:** TI defines "Green" to mean the content of Chlorine (Cl) and Bromine (Br) based flame retardants meet JS709B low halogen requirements of <=1000ppm threshold. Antimony trioxide based flame retardants must also meet the <=1000ppm threshold requirement.

(3) MSL, Peak Temp. - The Moisture Sensitivity Level rating according to the JEDEC industry standard classifications, and peak solder temperature.

(4) There may be additional marking, which relates to the logo, the lot trace code information, or the environmental category on the device.

(5) Multiple Device Markings will be inside parentheses. Only one Device Marking contained in parentheses and separated by a "~" will appear on a device. If a line is indented then it is a continuation of the previous line and the two combined represent the entire Device Marking for that device.

<sup>(6)</sup> Lead finish/Ball material - Orderable Devices may have multiple material finish options. Finish options are separated by a vertical ruled line. Lead finish/Ball material values may wrap to two lines if the finish value exceeds the maximum column width.

**Important Information and Disclaimer:** The information provided on this page represents TI's knowledge and belief as of the date that it is provided. TI bases its knowledge and belief on information provided by third parties, and makes no representation or warranty as to the accuracy of such information. Efforts are underway to better integrate information from third parties. TI has taken and continues to take reasonable steps to provide representative and accurate information but may not have conducted destructive testing or chemical analysis on incoming materials and chemicals. TI and TI suppliers consider certain information to be proprietary, and thus CAS numbers and other limited information may not be available for release.

In no event shall TI's liability arising out of such information exceed the total purchase price of the TI part(s) at issue in this document sold by TI to Customer on an annual basis.



**TAPE AND REEL INFORMATION**

**QUADRANT ASSIGNMENTS FOR PIN 1 ORIENTATION IN TAPE**


\*All dimensions are nominal

Device	Package Type	Package Drawing	Pins	SPQ	Reel Diameter (mm)	Reel Width W1 (mm)	A0 (mm)	B0 (mm)	K0 (mm)	P1 (mm)	W (mm)	Pin1 Quadrant
ISO6520DR	SOIC	D	8	3000	330.0	12.4	6.4	5.2	2.1	8.0	12.0	Q1
ISO6520FDR	SOIC	D	8	3000	330.0	12.4	6.4	5.2	2.1	8.0	12.0	Q1
ISO6521DR	SOIC	D	8	3000	330.0	12.4	6.4	5.2	2.1	8.0	12.0	Q1
ISO6521FDR	SOIC	D	8	3000	330.0	12.4	6.4	5.2	2.1	8.0	12.0	Q1
ISO6521FREUR	VSON	REU	8	3000	180.0	12.4	2.3	3.3	1.2	4.0	12.0	Q2

**TAPE AND REEL BOX DIMENSIONS**


\*All dimensions are nominal

Device	Package Type	Package Drawing	Pins	SPQ	Length (mm)	Width (mm)	Height (mm)
ISO6520DR	SOIC	D	8	3000	353.0	353.0	32.0
ISO6520FDR	SOIC	D	8	3000	353.0	353.0	32.0
ISO6521DR	SOIC	D	8	3000	353.0	353.0	32.0
ISO6521FDR	SOIC	D	8	3000	353.0	353.0	32.0
ISO6521FREUR	VSON	REU	8	3000	210.0	185.0	35.0



D0008A

# PACKAGE OUTLINE

SOIC - 1.75 mm max height

SMALL OUTLINE INTEGRATED CIRCUIT



4214825/C 02/2019

### NOTES:

- Linear dimensions are in inches [millimeters]. Dimensions in parenthesis are for reference only. Controlling dimensions are in inches. Dimensioning and tolerancing per ASME Y14.5M.
- This drawing is subject to change without notice.
- This dimension does not include mold flash, protrusions, or gate burrs. Mold flash, protrusions, or gate burrs shall not exceed  $.006$  [0.15] per side.
- This dimension does not include interlead flash.
- Reference JEDEC registration MS-012, variation AA.

# EXAMPLE BOARD LAYOUT

D0008A

SOIC - 1.75 mm max height

SMALL OUTLINE INTEGRATED CIRCUIT



LAND PATTERN EXAMPLE  
 EXPOSED METAL SHOWN  
 SCALE:8X



SOLDER MASK DETAILS

4214825/C 02/2019

NOTES: (continued)

- 6. Publication IPC-7351 may have alternate designs.
- 7. Solder mask tolerances between and around signal pads can vary based on board fabrication site.

# EXAMPLE STENCIL DESIGN

D0008A

SOIC - 1.75 mm max height

SMALL OUTLINE INTEGRATED CIRCUIT



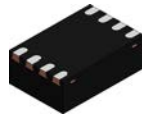
SOLDER PASTE EXAMPLE  
BASED ON .005 INCH [0.125 MM] THICK STENCIL  
SCALE:8X

4214825/C 02/2019

NOTES: (continued)

8. Laser cutting apertures with trapezoidal walls and rounded corners may offer better paste release. IPC-7525 may have alternate design recommendations.
9. Board assembly site may have different recommendations for stencil design.

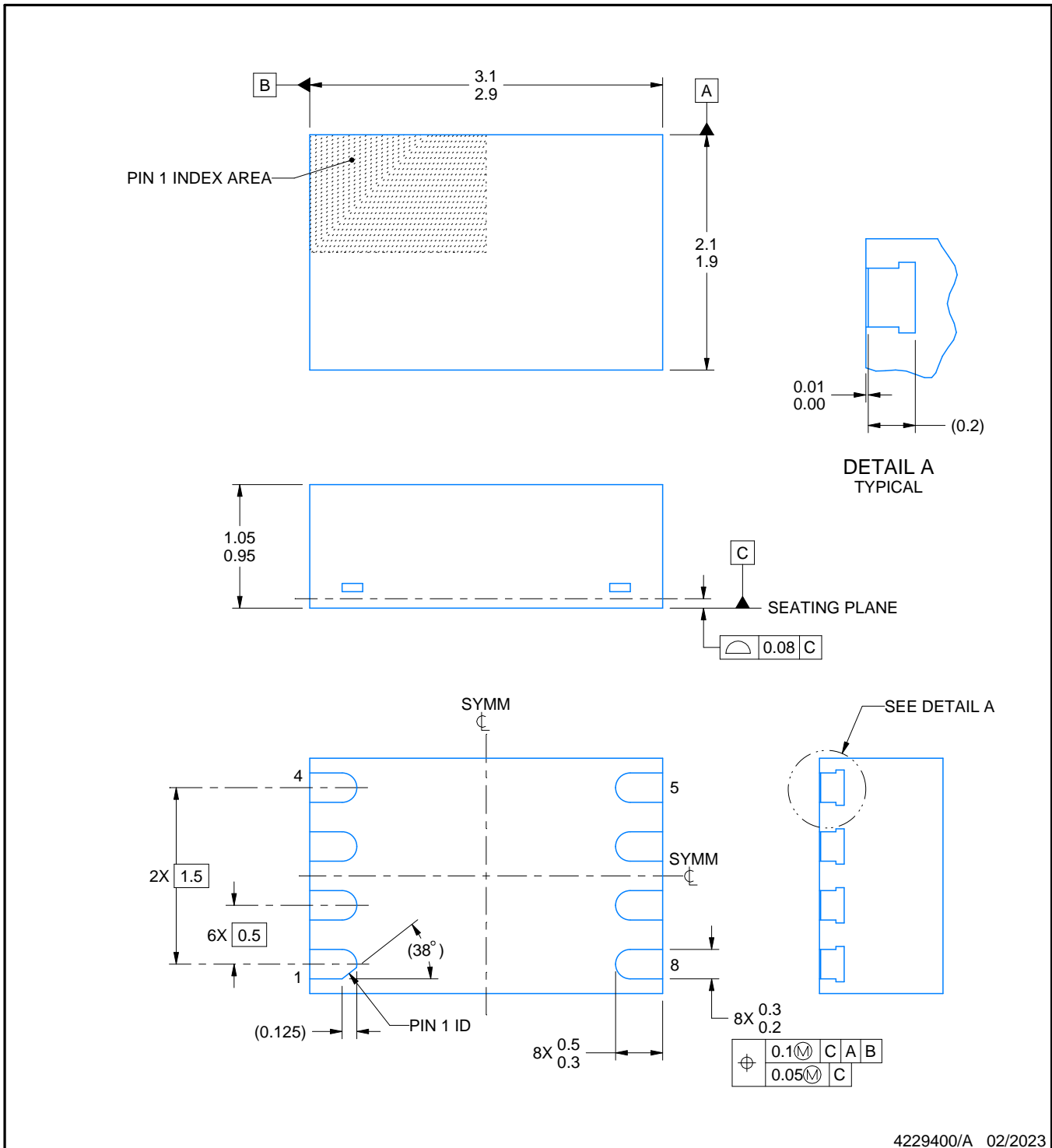
REU0008A



PACKAGE OUTLINE

VSON - 1.05 mm max height

PLASTIC SMALL OUTLINE - NO LEAD



NOTES:

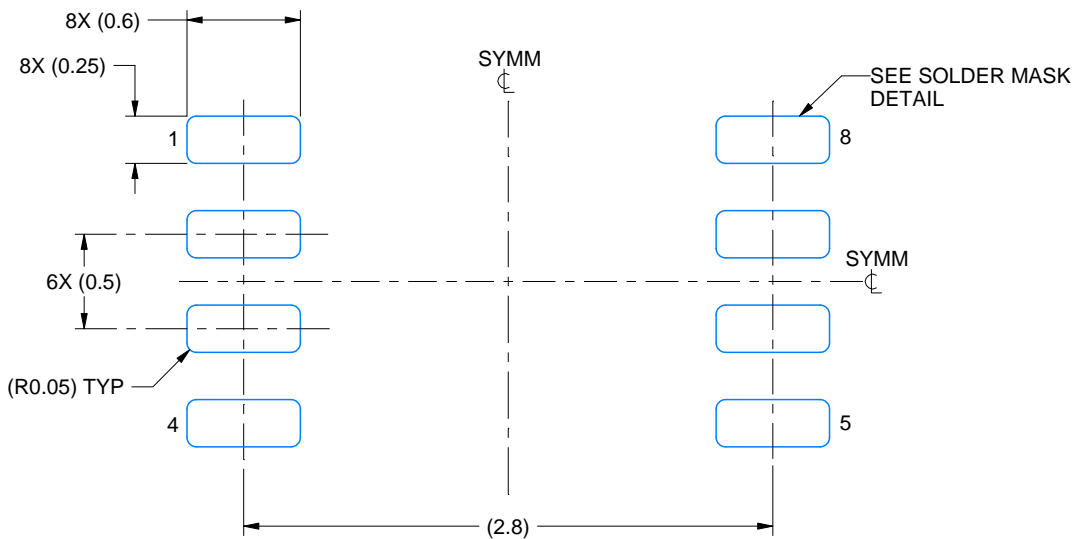
1. All linear dimensions are in millimeters. Any dimensions in parenthesis are for reference only. Dimensioning and tolerancing per ASME Y14.5M.
2. This drawing is subject to change without notice.

# EXAMPLE BOARD LAYOUT

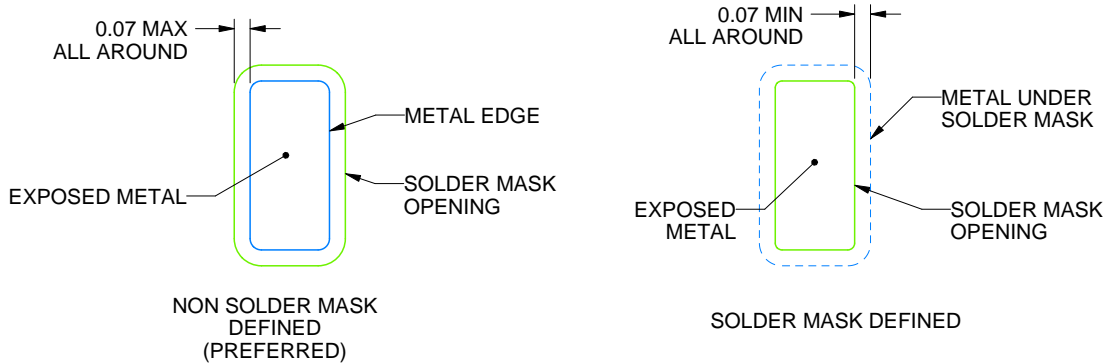
REU0008A

VSON - 1.05 mm max height

PLASTIC SMALL OUTLINE - NO LEAD



LAND PATTERN EXAMPLE  
EXPOSED METAL SHOWN  
SCALE: 25X



SOLDER MASK DETAILS

4229400/A 02/2023

NOTES: (continued)

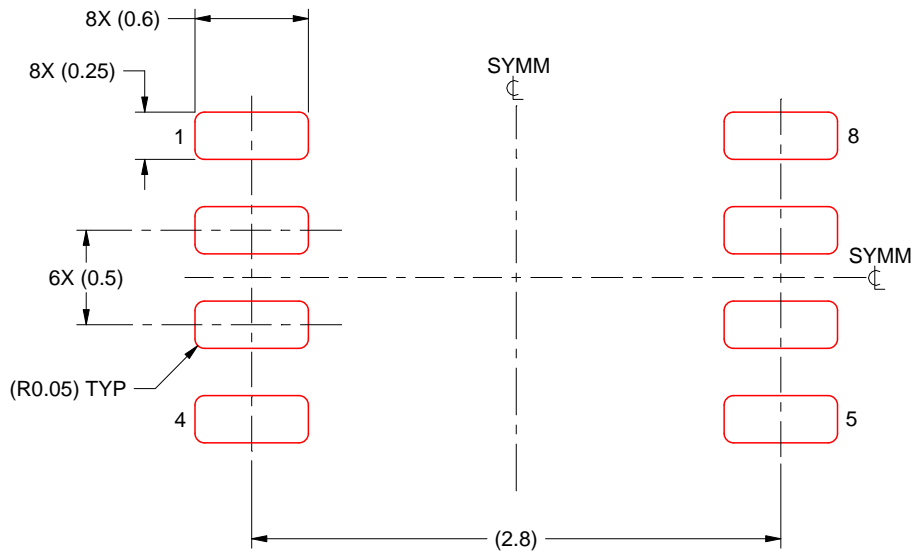
3. For more information, see Texas Instruments literature number SLUA271 ([www.ti.com/lit/slua271](http://www.ti.com/lit/slua271)).

# EXAMPLE STENCIL DESIGN

REU0008A

VSON - 1.05 mm max height

PLASTIC SMALL OUTLINE - NO LEAD



SOLDER PASTE EXAMPLE  
BASED ON 0.125 MM THICK STENCIL  
SCALE: 25X

4229400/A 02/2023

NOTES: (continued)

4. Laser cutting apertures with trapezoidal walls and rounded corners may offer better paste release. IPC-7525 may have alternate design recommendations.



## IMPORTANT NOTICE AND DISCLAIMER

TI PROVIDES TECHNICAL AND RELIABILITY DATA (INCLUDING DATA SHEETS), DESIGN RESOURCES (INCLUDING REFERENCE DESIGNS), APPLICATION OR OTHER DESIGN ADVICE, WEB TOOLS, SAFETY INFORMATION, AND OTHER RESOURCES "AS IS" AND WITH ALL FAULTS, AND DISCLAIMS ALL WARRANTIES, EXPRESS AND IMPLIED, INCLUDING WITHOUT LIMITATION ANY IMPLIED WARRANTIES OF MERCHANTABILITY, FITNESS FOR A PARTICULAR PURPOSE OR NON-INFRINGEMENT OF THIRD PARTY INTELLECTUAL PROPERTY RIGHTS.

These resources are intended for skilled developers designing with TI products. You are solely responsible for (1) selecting the appropriate TI products for your application, (2) designing, validating and testing your application, and (3) ensuring your application meets applicable standards, and any other safety, security, regulatory or other requirements.

These resources are subject to change without notice. TI grants you permission to use these resources only for development of an application that uses the TI products described in the resource. Other reproduction and display of these resources is prohibited. No license is granted to any other TI intellectual property right or to any third party intellectual property right. TI disclaims responsibility for, and you will fully indemnify TI and its representatives against, any claims, damages, costs, losses, and liabilities arising out of your use of these resources.

TI's products are provided subject to [TI's Terms of Sale](#) or other applicable terms available either on [ti.com](https://www.ti.com) or provided in conjunction with such TI products. TI's provision of these resources does not expand or otherwise alter TI's applicable warranties or warranty disclaimers for TI products.

TI objects to and rejects any additional or different terms you may have proposed.

Mailing Address: Texas Instruments, Post Office Box 655303, Dallas, Texas 75265  
Copyright © 2024, Texas Instruments Incorporated