

GAIN +4 STABLE WIDEBAND VOLTAGE LIMITING AMPLIFIER

FEATURES

- High Linearity Near Limiting
- Fast Recovery from Overdrive: 1 ns
- Limiting Voltage Accuracy: ± 15 mV
- -3 -dB Bandwidth ($G = +6$): 260 MHz
- Stable for $G \geq +4$
- Slew Rate: 1400 V/ μ s
- ± 5 -V and 5-V Supply Operation
- High Gain Version of the OPA698
- Low Prop Delay Comparator
- Non-Linear Analog Signal Processing
- Difference Amplifier
- IF Limiting Amplifier
- OPA689M Replacement

APPLICATIONS

- Transimpedance With Fast Overdrive Recovery
- Fast Limiting ADC Input Buffers

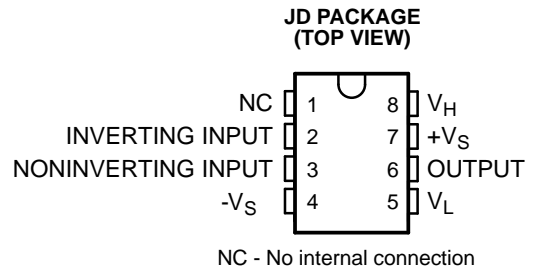

P0013-01

DESCRIPTION

The OPA699 is a wideband, voltage feedback op amp that offers bipolar output voltage limiting, and is stable for gains $\geq +4$. Two buffered limiting voltages take control of the output when it attempts to drive beyond these limits. This new output limiting architecture holds the limiter offset error to ± 15 mV. The op amp operates linearly to within 30 mV of the limits.

The combination of narrow nonlinear range and low limiting offset allows the limiting voltages to be set within 100 mV of the desired linear output range 1-ns recovery from limiting ensures that overdrive signals will be transparent to the signal channel. Implementing the limiting function at the output, as opposed to the input, gives the specified limiting accuracy for any gain and allows the OPA699 to be used in all standard op amp applications.

Non-linear analog signal processing circuits will benefit from the ability of the OPA699 to sharply transition from linear operation to output limiting. The quick recovery time supports high speed applications.

The OPA699M is available in an industry-standard pinout in a CDIP-8 package. For lower gain applications requiring output limiting with fast recovery, consider the OPA698M.

ORDERING INFORMATION⁽¹⁾

T _A	PACKAGE		ORDERABLE PART NUMBER	TOP-SIDE MARKING
-55°C to 125°C	CDIP – JD	Tube	OPA699MJD	OPA699MJD

- (1) Package drawings, standard packing quantities, thermal data, symbolization, and PCB design guidelines are available at www.ti.com/sc/package.



Please be aware that an important notice concerning availability, standard warranty, and use in critical applications of Texas Instruments semiconductor products and disclaimers thereto appears at the end of this data sheet.



These devices have limited built-in ESD protection. The leads should be shorted together or the device placed in conductive foam during storage or handling to prevent electrostatic damage to the MOS gates.

ABSOLUTE MAXIMUM RATINGS

over operating free-air temperature range (unless otherwise noted)⁽¹⁾

		UNIT
	Power supply	±6.5 V
V _{ICM}	Common-mode input voltage	±V _S
V _{ID}	Differential input voltage	±V _S
	Limiter voltage range	±(V _S - 0.7 V)
T _A	Operating free-air temperature range	-55°C to 125°C
T _{stg}	Storage temperature range	-65°C to 150°C
	Lead temperature 1,6 mm (1/16 inch) from case for 10 seconds	300°C
	Case temperature for 10 seconds	260°C
T _J	Junction temperature	150°C
θ _{JC}	Package thermal impedance ⁽²⁾ (JD Package)	14.5°C/W

- (1) Stresses beyond those listed under "absolute maximum ratings" may cause permanent damage to the device. These are stress ratings only, and functional operation of the device at these or any other conditions beyond those indicated under "recommended operating conditions" is not implied. Exposure to absolute-maximum-rated conditions for extended periods may affect device reliability.
- (2) The package thermal impedance is measured per MIL-STD-883, Method 1012.1.

RECOMMENDED OPERATING CONDITIONS

		MIN	NOM	MAX	UNIT
Operating voltage	Split-rail operation		±5	±6	V
	Single-supply operation		5	12	
Operating free-air temperature		-55		125	°C

ELECTRICAL CHARACTERISTICS
 $V_S = \pm 5\text{ V}$, $V_{ICM} = 0\text{ V}$, $R_L = 500\ \Omega$, limiter pins open (unless otherwise noted)⁽¹⁾

PARAMETER	TEST CONDITIONS	MIN	TYP	MAX	UNIT
AC PERFORMANCE (see Figure 47)					
Small signal bandwidth	$V_O < 0.5\text{ Vp-p}$, $G = +6$		260		MHz
	$V_O < 0.5\text{ Vp-p}$, $G = +12$		86		
	$V_O < 0.5\text{ Vp-p}$, $G = -6$		269		
Gain bandwidth product ($G \geq +20$)	$V_O < 0.5\text{ Vp-p}$		1000		MHz
Gain peaking	$V_O = 0.5\text{ V}$, $G = +4$		7.5		dB
Bandwidth for 0.1-dB gain flatness	$V_O = 0.5\text{ V}$		30		MHz
Large signal bandwidth	$V_O = 2\text{ Vp-p}$		290		MHz
Slew rate	$V_O = 2\text{ V step}$		1400		V/ μs
Rise and fall time	$V_O = 0.5\text{ V step}$		1.6		ns
Settling time to 0.05%	$V_O = 2\text{ V step}$		8		ns
Spurious free dynamic range	$V_O = 2\text{ Vp-p}$, $f = 5\text{ MHz}$	Even	67		dB
		Odd	87		
Differential gain	$R_L = 500\ \Omega$, NTSC, PAL		0.012%		
Differential phase	$R_L = 500\ \Omega$, NTSC, PAL		0.008		°
Input noise, voltage noise density	$f \geq 1\text{ MHz}$		4.1		nV/ $\sqrt{\text{Hz}}$
Input noise, current noise density	$f \geq 1\text{ MHz}$		2		pA/ $\sqrt{\text{Hz}}$
DC PERFORMANCE					
Open-loop voltage gain (AVOL)	$V_O = \pm 0.5\text{ V}$	$T_A = 25^\circ\text{C}$	54	62	dB
		$T_A = \text{Full range}$	47		
Input offset voltage (V_{IO})		$T_A = 25^\circ\text{C}$	± 1.5	± 8	mV
		$T_A = \text{Full range}$		± 12	
Input bias current (I_{IB}) ⁽²⁾		$T_A = 25^\circ\text{C}$	3	± 10	μA
		$T_A = \text{Full range}$		± 18	
Input offset current (I_{IO})		$T_A = 25^\circ\text{C}$	± 0.3	± 3	μA
		$T_A = \text{Full range}$		± 4	
INPUT					
Common-mode rejection ratio (CMRR)	$V_{ICM} = \pm 0.5\text{ V}$, Input referred	$T_A = 25^\circ\text{C}$	54	62	dB
		$T_A = \text{Full range}$	50		
Common-mode input voltage range (V_{ICR}) ⁽³⁾		$T_A = 25^\circ\text{C}$	± 3.2	± 3.3	V
		$T_A = \text{Full range}$	± 3.1		
Input impedance, differential mode			0.32 1		M Ω pF
Input impedance, common mode			3.5 1		M Ω pF
OUTPUT					
Output voltage range (V_{OH} , V_{OL})	$V_H = 4.3\text{ V}$, $V_L = -4.3\text{ V}$, $R_L \geq 500\ \Omega$	$T_A = 25^\circ\text{C}$	± 3.9	± 4.1	V
		$T_A = \text{Full range}$	± 3.7		
Current output, sourcing (I_{OH})	$V_H = 4.3\text{ V}$, $V_L = -4.3\text{ V}$, $R_L = 20\ \Omega$	$T_A = 25^\circ\text{C}$	110	165	mA
		$T_A = \text{Full range}$	100		
Current output, sinking (I_{OL})	$V_H = 4.3\text{ V}$, $V_L = -4.3\text{ V}$, $R_L = 20\ \Omega$	$T_A = 25^\circ\text{C}$	-90	-130	mA
		$T_A = \text{Full range}$	-80		
Closed-loop output impedance	$G = +4$, $f < 100\text{ kHz}$		0.8		Ω

(1) All typical limits are at $T_A = 25^\circ\text{C}$ unless otherwise specified.

(2) Current is considered positive out of node.

(3) CMIR tested as $< 3\text{-dB}$ degradation from minimum CMRR at specified limits.

ELECTRICAL CHARACTERISTICS (continued)
 $V_S = \pm 5\text{ V}$, $V_{ICM} = 0\text{ V}$, $R_L = 500\ \Omega$, limiter pins open (unless otherwise noted)

PARAMETER	TEST CONDITIONS	MIN	TYP	MAX	UNIT	
POWER SUPPLY						
Operating voltage (V_S)			± 5	± 6	V	
Quiescent current (I_S)		$T_A = 25^\circ\text{C}$	15	15.5	16	mA
		$T_A = \text{Full range}$	13.5		18	
Power supply rejection ratio (PSRR)	Input referred, $V_S = \pm 4.5\text{ V}$ to $\pm 5.5\text{ V}$	$T_A = 25^\circ\text{C}$	65	76		dB
		$T_A = \text{Full range}$	60			
OUTPUT VOLTAGE LIMITERS (PINS 5 AND 8)						
Default output limited voltage	Limiter pins open	$T_A = 25^\circ\text{C}$	± 3.3	± 3.6		V
		$T_A = \text{Full range}$	± 3			
Limiter output offset voltage	$(V_{O-} - V_H)$ or $(V_{O-} - V_L)$	$T_A = \text{Full range}$		± 15	± 50	mV
Limiter input bias current magnitude ⁽⁴⁾	$V_O = 0\text{ V}$	$T_A = 25^\circ\text{C}$	40	55	65	μA
		$T_A = \text{Full range}$	35		70	
Limiter input impedance			3.4 1		$\text{M}\Omega$ pF	
Limiter feedthrough ⁽⁵⁾	$f = 5\text{ MHz}$			-60		dB
Maximum limiter voltage				± 4.3		V
Minimum limiter voltage separation		400				mV
Op amp bias current shift ⁽²⁾			3			μA
Limiter small signal bandwidth	$V_I = \pm 2\text{ V}$, $V_O < 0.02\text{ V}_{p-p}$		600			MHz
Limiter slew rate ⁽⁶⁾			125			V/ μs
Limiter step response, overshoot	$V_I = \pm 2\text{ V}$		250			mV
Limiter step response, recovery time	$V_I = \pm 2\text{ V}$		1			ns
Linearity guardband ⁽⁷⁾	$V_O = 2\text{ V}_{p-p}$, $f = 5\text{ MHz}$		30			mV

(4) I_{VH} (V_H bias current) is positive and I_{VL} (V_L bias current) is negative, under these conditions. See Note 2, [Figure 47](#), and [Figure 58](#).

(5) Limiter feedthrough is the ratio of the output magnitude to the sinewave added to V_H (or V_L) when $V_{IN} = 0$.

(6) V_H slew rate conditions are: $V_{IN} = +0.7\text{ V}$, $G = +6$, $V_L = -2\text{ V}$, $V_H = \text{step between } 2\text{ V and } 0\text{ V}$. V_L slew rate conditions are similar.

(7) Linearity Guardband is defined for an output sinusoid ($f = 1\text{ MHz}$, $V_O = 2\text{ V}_{p-p}$) centered between the limiter levels (V_H and V_L). It is the difference between the limiter level and the peak output voltage where SFDR decreases by 3 dB (see [Figure 59](#)).

ELECTRICAL CHARACTERISTICS

$V_S = 5\text{ V}$, $V_{ICM} = 2.5\text{ V}$, $R_L = 500\ \Omega$, limiter pins open (unless otherwise noted)⁽¹⁾

PARAMETER	TEST CONDITIONS		MIN	TYP	MAX	UNIT
AC PERFORMANCE (see Figure 48)						
Small signal bandwidth	$V_O < 0.5\text{ Vp-p}$, $G = +6$		234		MHz	
	$V_O < 0.5\text{ Vp-p}$, $G = +12$		83			
	$V_O < 0.5\text{ Vp-p}$, $G = -6$		242			
Gain bandwidth product	$V_O < 0.5\text{ Vp-p}$, $G \geq +20$		880		MHz	
Gain peaking	$V_O < 0.5\text{ V}$, $G = +4$		8		dB	
Bandwidth for 0.1-dB gain flatness	$V_O = 0.5\text{ Vp-p}$		30		MHz	
Large signal bandwidth	$V_O = 2\text{ Vp-p}$		250		MHz	
Slew rate	$V_O = 2\text{ V step}$		1050		V/ μs	
Rise and fall time	$V_O = 0.5\text{ V step}$		1.75		ns	
Settling time to 0.05%	2 V step		8		ns	
Spurious free dynamic range	$V_O = 2\text{ Vp-p}$, $f = 5\text{ MHz}$	Even	64		dB	
		Odd	70			
Input noise, voltage noise density	$f \geq 1\text{ MHz}$		4.2		nV/ $\sqrt{\text{Hz}}$	
Input noise, current noise density	$f \geq 1\text{ MHz}$		2.1		pA/ $\sqrt{\text{Hz}}$	
DC PERFORMANCE						
Open-loop voltage gain (AVOL)	$V_O = \pm 0.4\text{ V}$	$T_A = 25^\circ\text{C}$	54	61	dB	
		$T_A = \text{Full range}$	47			
Input offset voltage (V_{IO})		$T_A = 25^\circ\text{C}$	± 2		mV	
		$T_A = \text{Full range}$	± 12			
Input bias current (I_{IB}) ⁽²⁾		$T_A = 25^\circ\text{C}$	± 3		μA	
		$T_A = \text{Full range}$	± 15			
Input offset current (I_{IO})		$T_A = 25^\circ\text{C}$	± 0.4		μA	
		$T_A = \text{Full range}$	± 4			
INPUT						
Common-mode rejection ratio (CMRR)	$V_{ICM} = \pm 0.5\text{ V}$, Input referred	$T_A = 25^\circ\text{C}$	52	60	dB	
		$T_A = \text{Full range}$	48			
Common-mode input voltage range (V_{ICR}) ⁽³⁾		$T_A = 25^\circ\text{C}$	V_{ICM} $\pm 0.7\text{ V}$	V_{ICM} $\pm 0.8\text{ V}$	V	
		$T_A = \text{Full range}$	V_{ICM} $\pm 0.6\text{ V}$			
Input impedance, differential mode			0.32	1	M Ω pF	
Input impedance, common mode			1	1	M Ω pF	
OUTPUT						
Output voltage range (V_{OH} , V_{OL})	$V_H = V_{ICM} + 1.8\text{ V}$, $V_L = V_{ICM} - 1.8\text{ V}$, $R_L \geq 500\ \Omega$	$T_A = 25^\circ\text{C}$	V_{ICM} $\pm 1.4\text{ V}$	V_{ICM} $\pm 1.6\text{ V}$	V	
		$T_A = \text{Full range}$	V_{ICM} $\pm 1.3\text{ V}$			
Current output, sourcing (I_{OH})	$V_S = \pm 2.5\text{ V}$, $R_L = 20\ \Omega$	$T_A = 25^\circ\text{C}$	70	100	mA	
		$T_A = \text{Full range}$	60			
Current output, sinking (I_{OL})	$V_S = \pm 2.5\text{ V}$, $R_L = 20\ \Omega$	$T_A = 25^\circ\text{C}$	-60	-90	mA	
		$T_A = \text{Full range}$	-50			
Closed-loop output impedance	$G = +4$, $f < 100\text{ kHz}$		0.2		Ω	

(1) All typical limits are at $T_A = 25^\circ\text{C}$ unless otherwise specified.

(2) Current is considered positive out of node.

(3) CMIR tested as <3-dB degradation from minimum CMRR at specified limits.

ELECTRICAL CHARACTERISTICS (continued)
 $V_S = 5\text{ V}$, $V_{ICM} = 2.5\text{ V}$, $R_L = 500\ \Omega$, limiter pins open (unless otherwise noted)

PARAMETER	TEST CONDITIONS	MIN	TYP	MAX	UNIT	
POWER SUPPLY						
Operating voltage (V_S)			5	12	V	
Quiescent current (I_S)		$T_A = 25^\circ\text{C}$	13.5	14.3	15	mA
		$T_A = \text{Full range}$	12		16.5	
Power supply rejection ratio (PSRR)	Input referred, $V_S = 4\text{ V to }6\text{ V}$	$T_A = \text{Full range}$	58	74		dB
OUTPUT VOLTAGE LIMITERS (PINS 5 AND 8)						
Default output limited voltage	Limiter pins open	$T_A = 25^\circ\text{C}$	$V_{ICM} \pm 0.8\text{ V}$	$V_{ICM} \pm 1.1\text{ V}$		V
		$T_A = \text{Full range}$	$V_{ICM} \pm 0.6\text{ V}$			
Limiter output offset voltage	$(V_O - V_H)$ or $(V_O - V_L)$	$T_A = \text{Full range}$		± 15	± 50	mV
Limiter input bias current magnitude ⁽⁴⁾	$V_O = 2.5\text{ V}$	$T_A = 25^\circ\text{C}$	40	50	65	μA
		$T_A = \text{Full range}$	35		70	
Limiter input bias current drift			30			nA/ $^\circ\text{C}$
Limiter input impedance			3.4			$\text{M}\Omega$
			1			pF
Limiter feedthrough ⁽⁵⁾	$f = 5\text{ MHz}$		-60			dB
Maximum limiter voltage				$V_{ICM} \pm 1.8\text{ V}$		V
Minimum limiter voltage separation		400				mV
Output bias current shift ⁽²⁾			5			μA
Limiter small signal bandwidth	$V_I = V_{ICM} \pm 0.4\text{ V}$, $V_O < 0.02\text{ Vp-p}$		450			MHz
Limiter slew rate ⁽⁶⁾			100			V/ μs
Limiter step response, overshoot	$V_I = V_{ICM} \pm 0.4\text{ V}$		55			mV
Limiter step response, recovery time	$V_I = V_{ICM} \pm 0.4\text{ V}$		3			ns
Linearity guardband ⁽⁷⁾	$V_O = 2\text{ Vp-p}$, $f = 5\text{ MHz}$		30			mV

(4) I_{VH} (V_H bias current) is positive and I_{VL} (V_L bias current) is negative, under these conditions. See Note 2, [Figure 47](#), and [Figure 58](#).

(5) Limiter feedthrough is the ratio of the output magnitude to the sinewave added to V_H (or V_L) when $V_{IN} = 0$.

(6) V_H slew rate conditions are: $V_{IN} = 0.7\text{ V}$, $G = +6$, $V_L = -2\text{ V}$, $V_H = \text{stepped between } 2\text{ V and } 0\text{ V}$. V_L slew rate conditions are similar.

(7) Linearity Guardband is defined for an output sinusoid ($f = 1\text{ MHz}$, $V_O = 2\text{ Vp-p}$) centered between the limiter levels (V_H and V_L). It is the difference between the limiter level and the peak output voltage where SFDR decreases by 3 dB (see [Figure 59](#)).

TYPICAL CHARACTERISTICS: $V_S = \pm 5\text{ V}$

$T_A = 25^\circ\text{C}$, $G = +6$, $R_F = 750\ \Omega$, and $R_L = 500\ \Omega$, $V_H = -V_L = 2\text{ V}$, unless otherwise noted

NONINVERTING SMALL-SIGNAL FREQUENCY RESPONSE

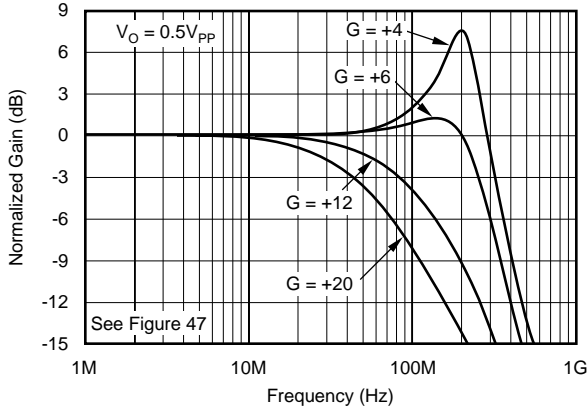

G001

Figure 1.

INVERTING SMALL-SIGNAL FREQUENCY RESPONSE

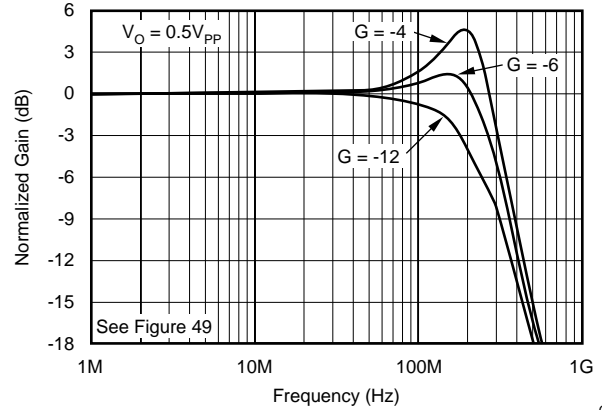

G002

Figure 2.

NONINVERTING LARGE-SIGNAL FREQUENCY RESPONSE

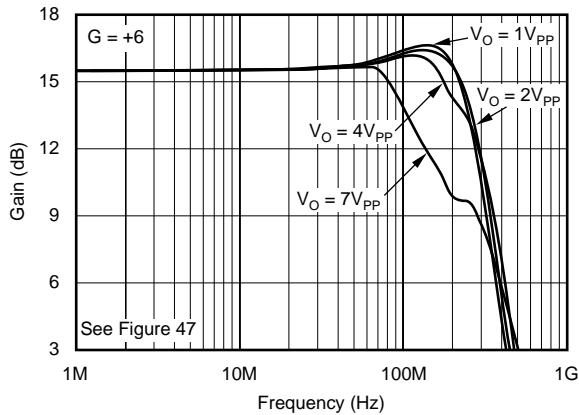

G003

Figure 3.

INVERTING LARGE-SIGNAL FREQUENCY RESPONSE

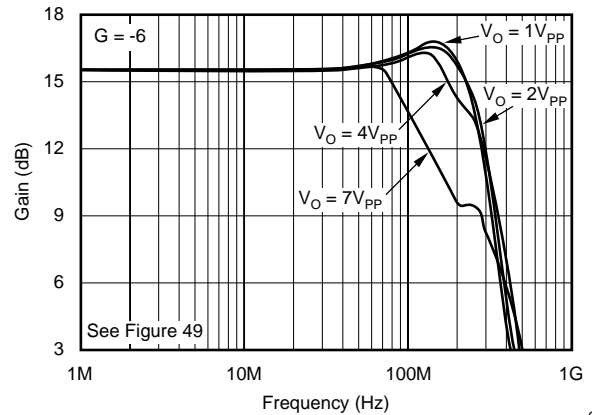

G004

Figure 4.

V_H -LIMITER SMALL-SIGNAL FREQUENCY RESPONSE

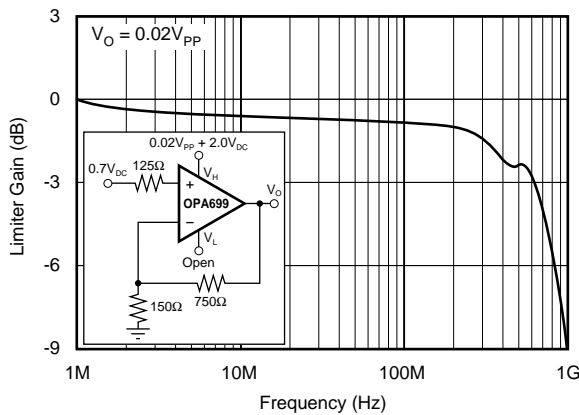

G005

Figure 5.

V_L -LIMITER SMALL-SIGNAL FREQUENCY RESPONSE

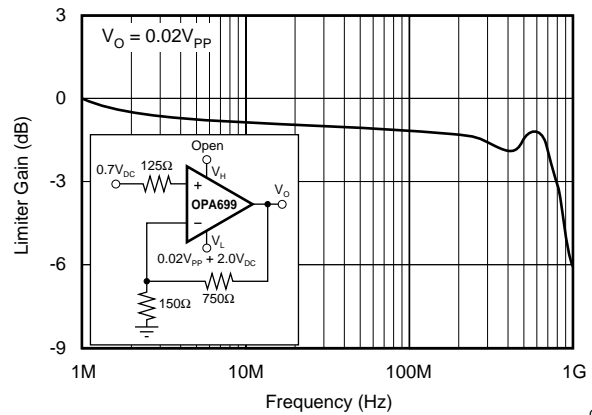

G006

Figure 6.

TYPICAL CHARACTERISTICS: $V_S = \pm 5\text{ V}$ (continued)

$T_A = 25^\circ\text{C}$, $G = +6$, $R_F = 750\ \Omega$, and $R_L = 500\ \Omega$, $V_H = -V_L = 2\text{ V}$, unless otherwise noted

SMALL-SIGNAL PULSE RESPONSE

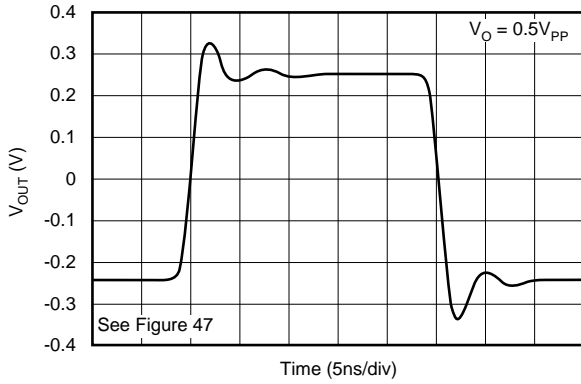

G007

Figure 7.

LARGE-SIGNAL PULSE RESPONSE

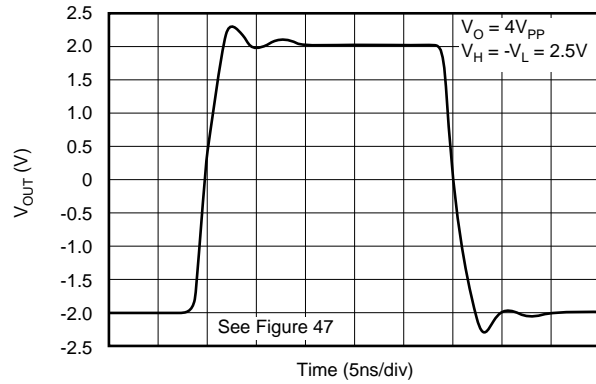

G008

Figure 8.

V_H -LIMITED PULSE RESPONSE

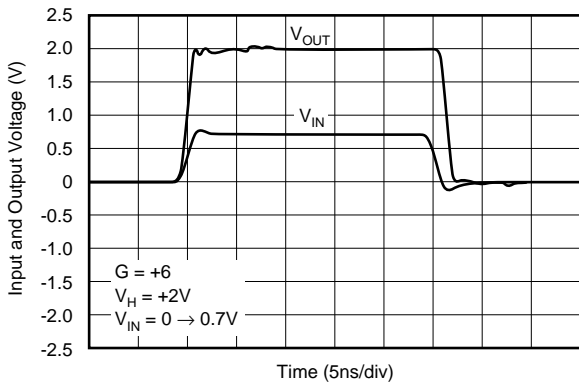

G009

Figure 9.

V_L -LIMITED PULSE RESPONSE

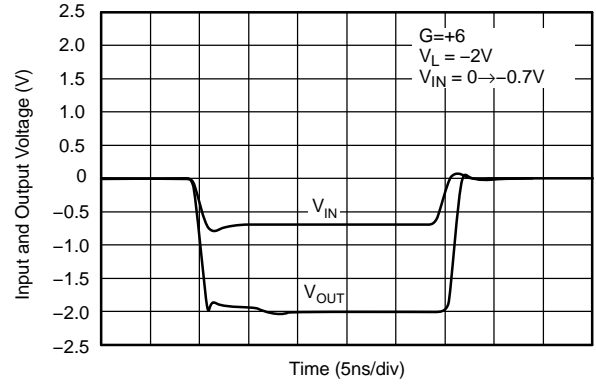

G010

Figure 10.

LIMITED OUTPUT RESPONSES

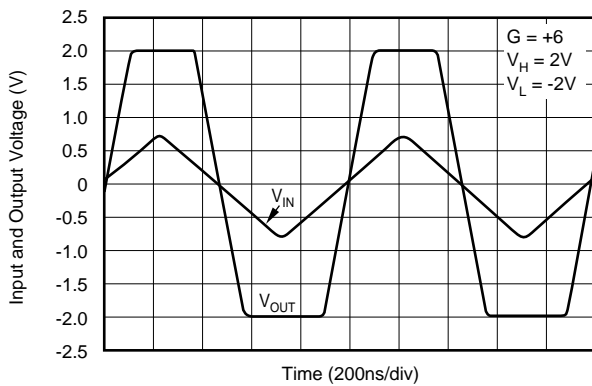

G011

Figure 11.

DETAIL OF LIMITED OUTPUT RESPONSE

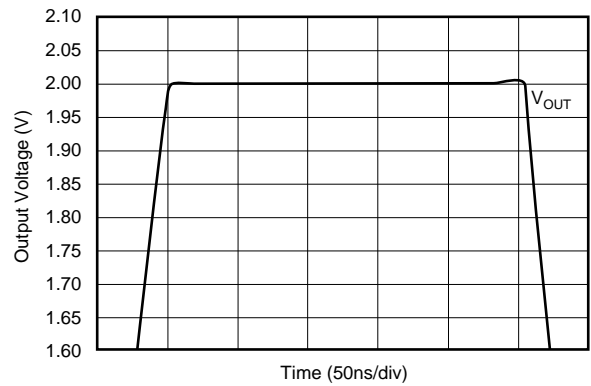

G012

Figure 12.

TYPICAL CHARACTERISTICS: $V_S = \pm 5\text{ V}$ (continued)

$T_A = 25^\circ\text{C}$, $G = +6$, $R_F = 750\ \Omega$, and $R_L = 500\ \Omega$, $V_H = -V_L = 2\text{ V}$, unless otherwise noted

**HARMONIC DISTORTION
vs
LOAD RESISTANCE**

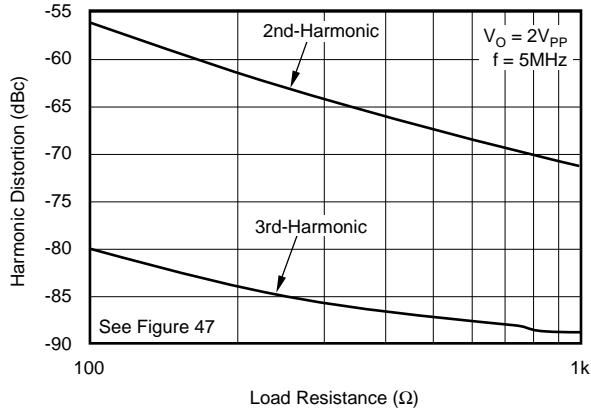

Figure 13.

**5 MHz HARMONIC DISTORTION
vs
SUPPLY VOLTAGE**

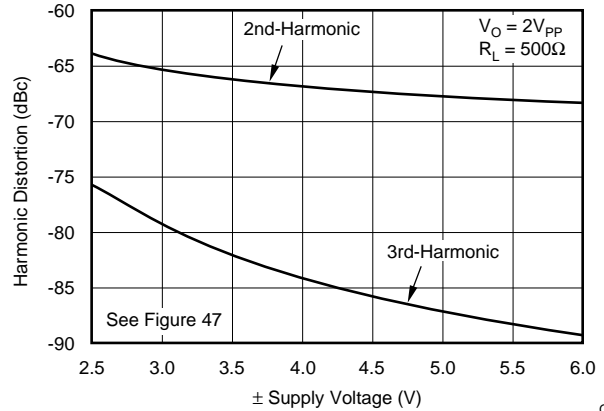

Figure 14.

**HARMONIC DISTORTION
vs
FREQUENCY**

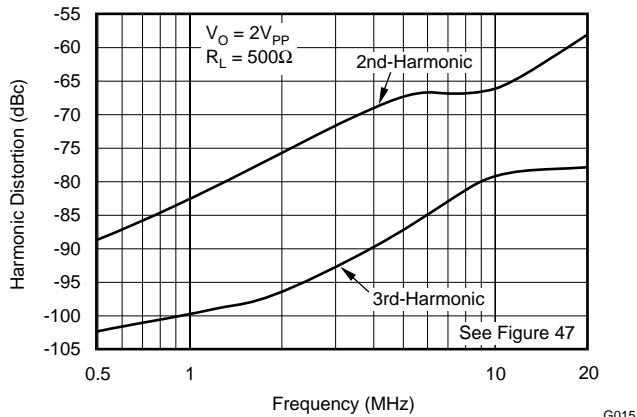

Figure 15.

**HARMONIC DISTORTION
vs
OUTPUT VOLTAGE**

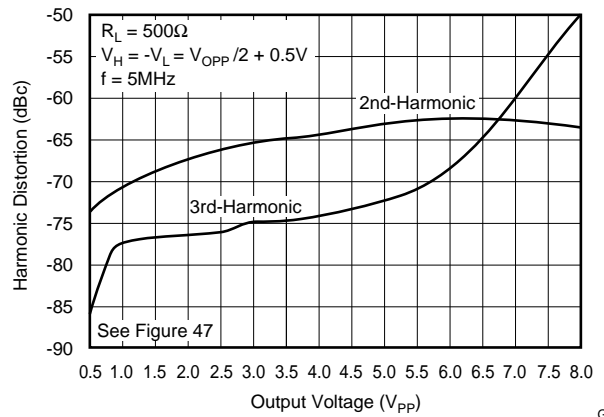

Figure 16.

TYPICAL CHARACTERISTICS: $V_S = \pm 5\text{ V}$ (continued)

$T_A = 25^\circ\text{C}$, $G = +6$, $R_F = 750\ \Omega$, and $R_L = 500\ \Omega$, $V_H = -V_L = 2\text{ V}$, unless otherwise noted

**HARMONIC DISTORTION
vs
NONINVERTING GAIN**

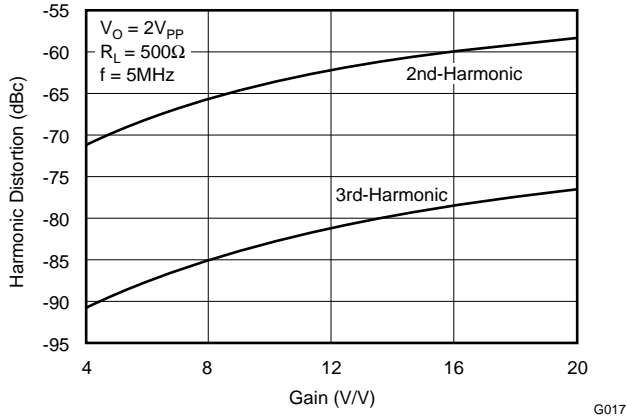

Figure 17.

**HARMONIC DISTORTION
vs
INVERTING GAIN**

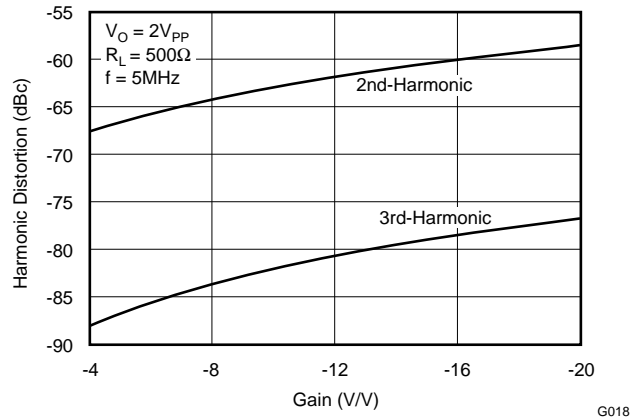

Figure 18.

**HARMONIC DISTORTION NEAR
LIMITING VOLTAGES**

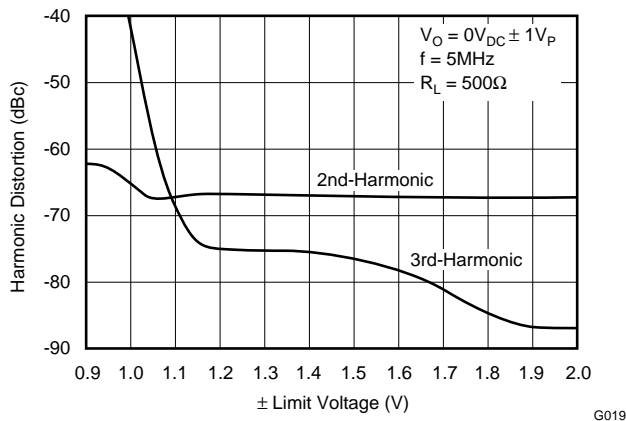

Figure 19.

**2-TONE, 3rd-ORDER
INTERMODULATION INTERCEPT**

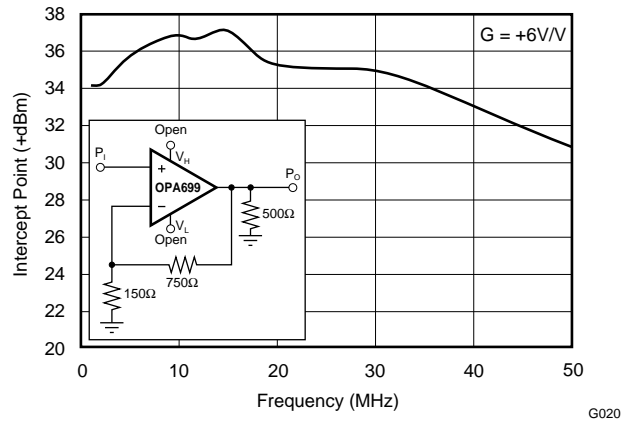

Figure 20.

TYPICAL CHARACTERISTICS: $V_S = \pm 5\text{ V}$ (continued)

$T_A = 25^\circ\text{C}$, $G = +6$, $R_F = 750\ \Omega$, and $R_L = 500\ \Omega$, $V_H = -V_L = 2\text{ V}$, unless otherwise noted

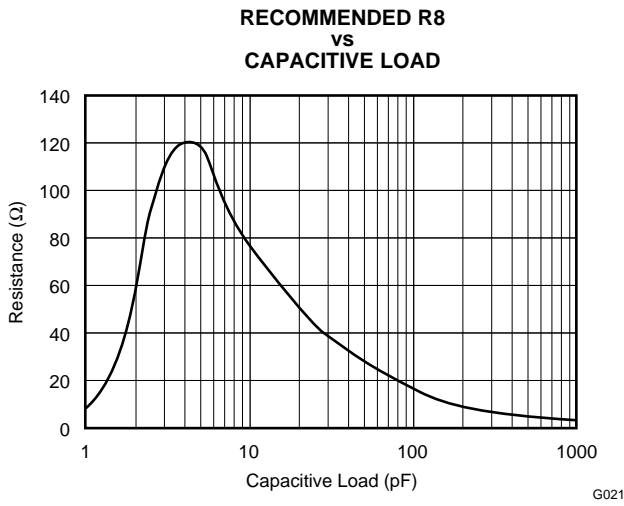

Figure 21.

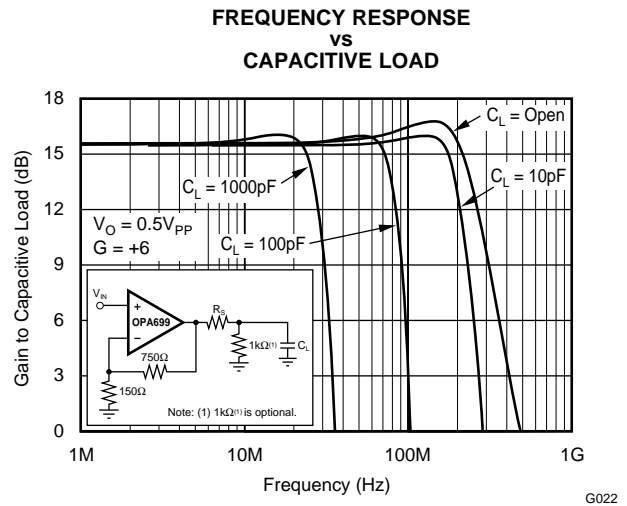

Figure 22.

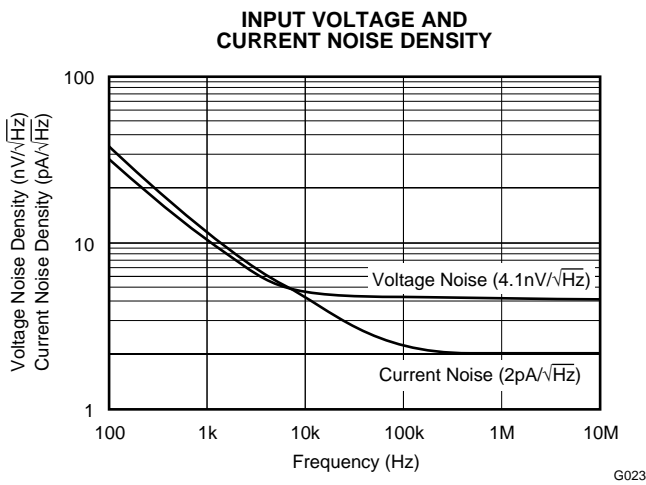

Figure 23.

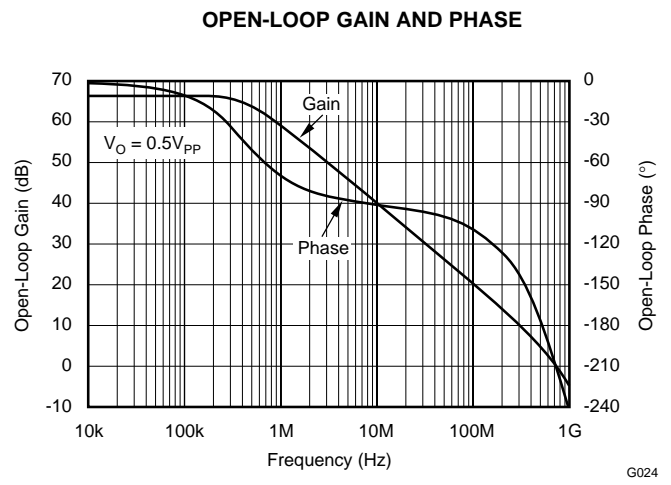

Figure 24.

TYPICAL CHARACTERISTICS: $V_S = \pm 5\text{ V}$ (continued)

$T_A = 25^\circ\text{C}$, $G = +6$, $R_F = 750\ \Omega$, and $R_L = 500\ \Omega$, $V_H = -V_L = 2\text{ V}$, unless otherwise noted

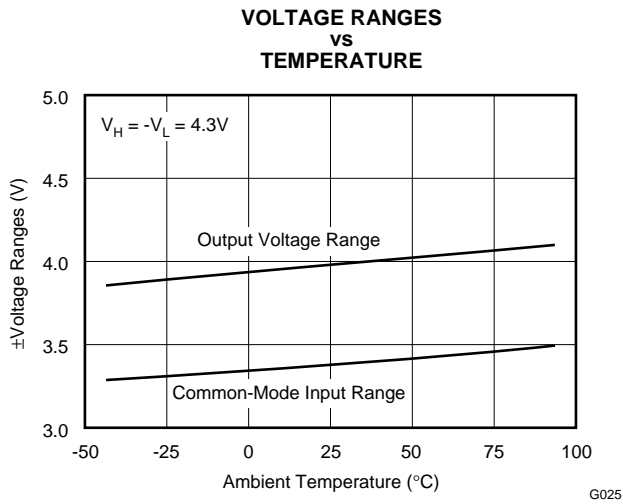

Figure 25.

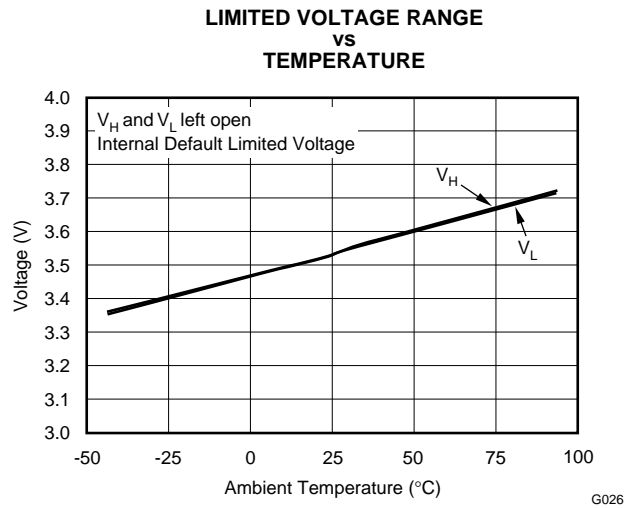

Figure 26.

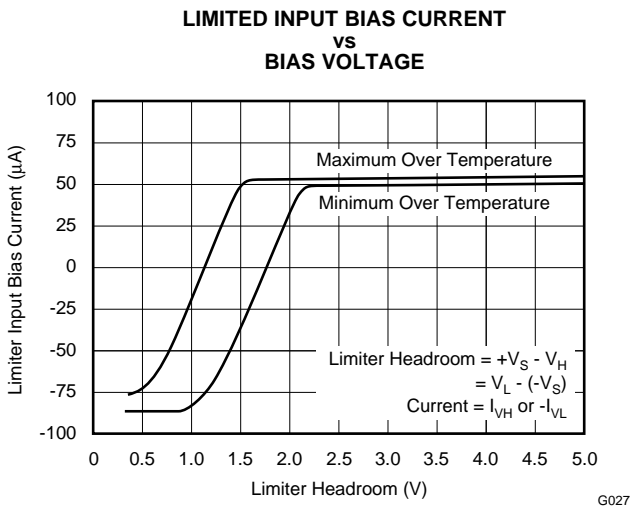

Figure 27.

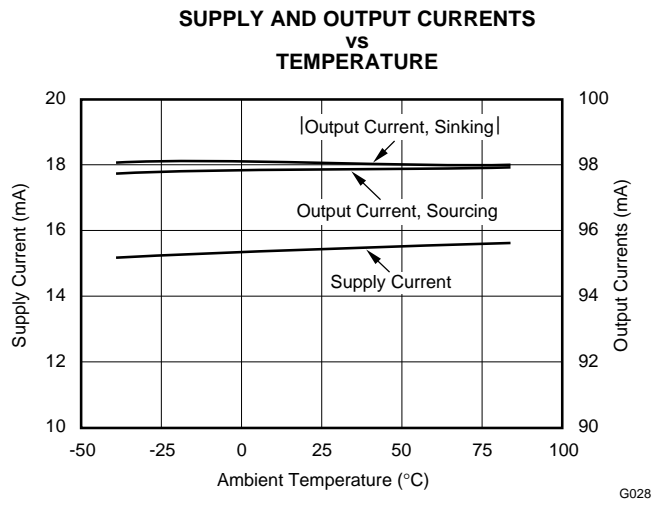

Figure 28.

TYPICAL CHARACTERISTICS: $V_S = \pm 5\text{ V}$ (continued)

$T_A = 25^\circ\text{C}$, $G = +6$, $R_F = 750\ \Omega$, and $R_L = 500\ \Omega$, $V_H = -V_L = 2\text{ V}$, unless otherwise noted

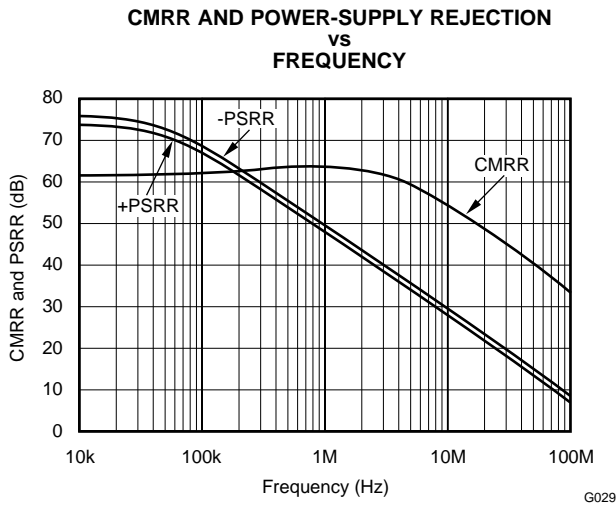

Figure 29.

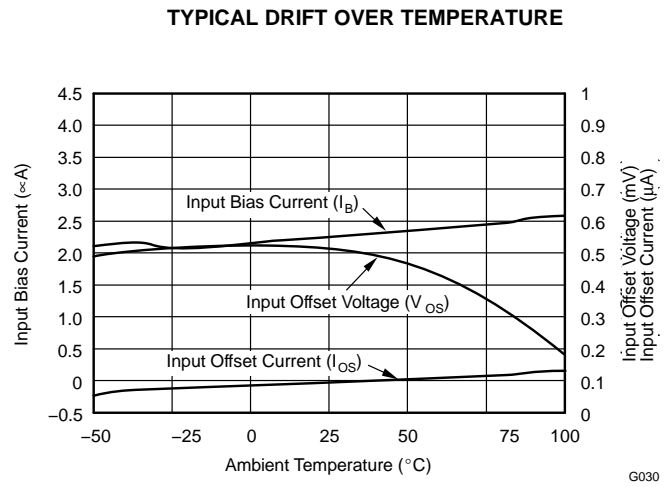

Figure 30.

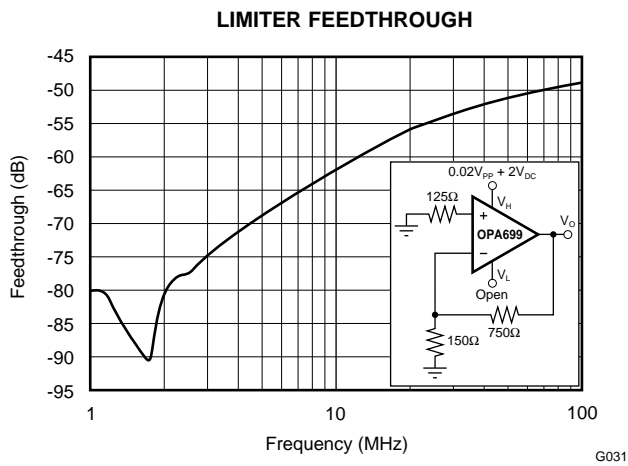

Figure 31.

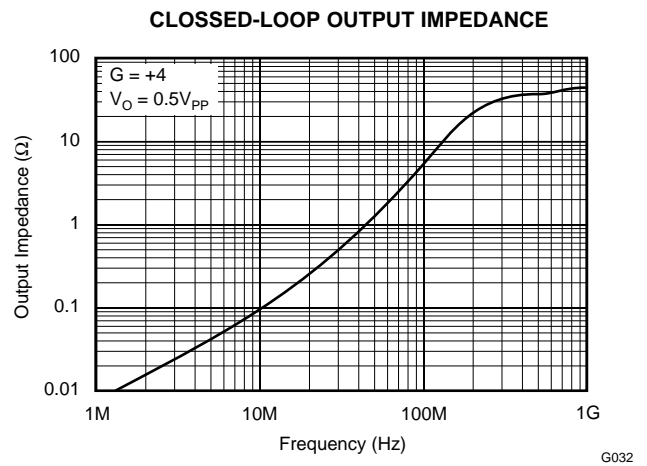

Figure 32.

TYPICAL CHARACTERISTICS: $V_S = \pm 5\text{ V}$ (continued)

$T_A = 25^\circ\text{C}$, $G = +6$, $R_F = 750\ \Omega$, and $R_L = 500\ \Omega$, $V_H = -V_L = 2\text{ V}$, unless otherwise noted

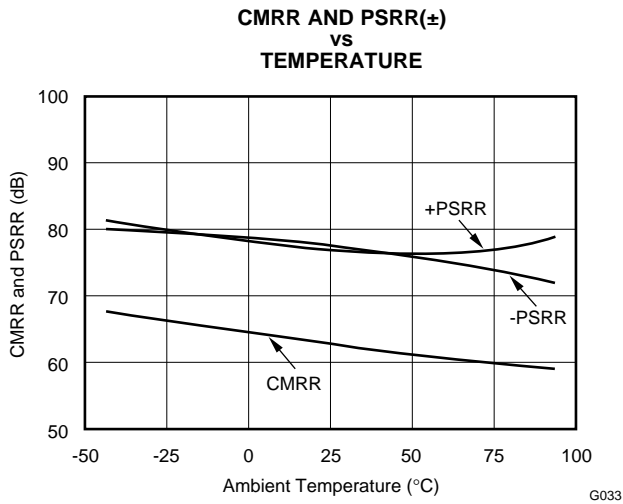

Figure 33.

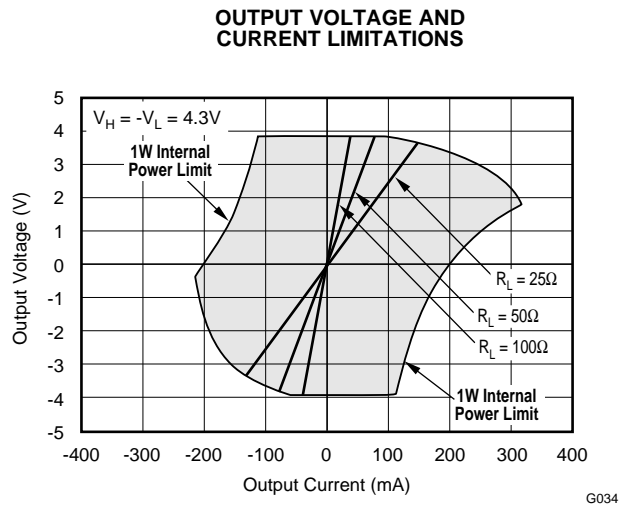

Figure 34.

TYPICAL CHARACTERISTICS $V_S = +5\text{ V}$

$T_A = 25^\circ\text{C}$, $G = +6$, $R_F = 750\ \Omega$, and $R_L = 500\ \Omega$ to $V_{CM} = +2.5\text{ V}$, $V_L = V_{CM} - 1.2\text{ V}$, $V_H = V_{CM} + 1.2\text{ V}$, unless otherwise noted

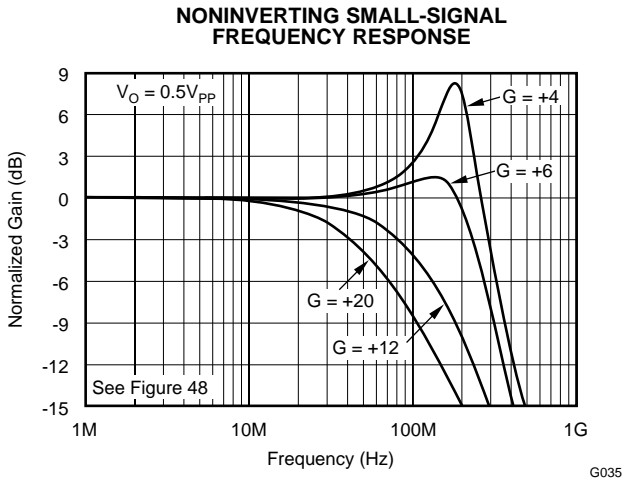

Figure 35.

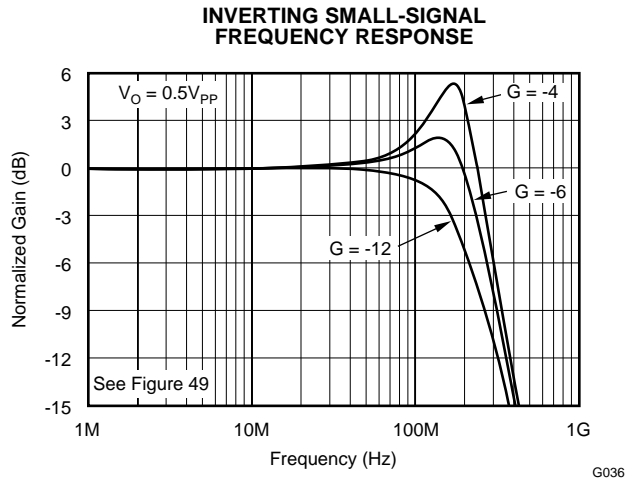

Figure 36.

TYPICAL CHARACTERISTICS $V_S = +5\text{ V}$ (continued)

$T_A = 25^\circ\text{C}$, $G = +6$, $R_F = 750\ \Omega$, and $R_L = 500\ \Omega$ to $V_{CM} = +2.5\text{ V}$, $V_L = V_{CM} - 1.2\text{ V}$, $V_H = V_{CM} + 1.2\text{ V}$, unless otherwise noted

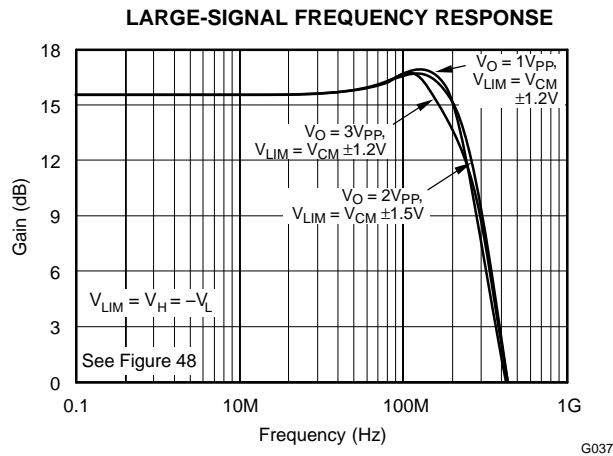

Figure 37.

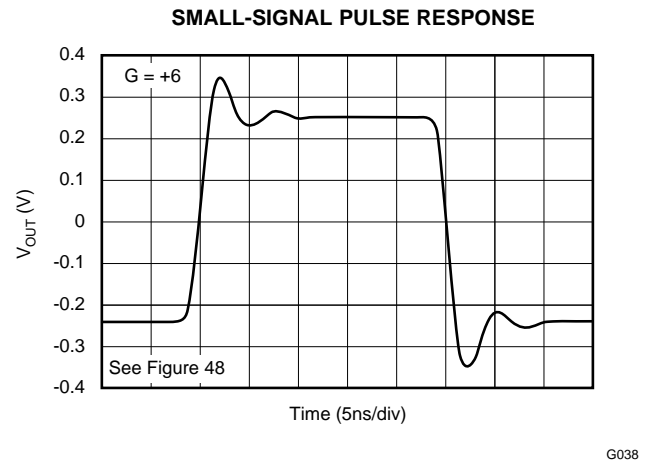

Figure 38.

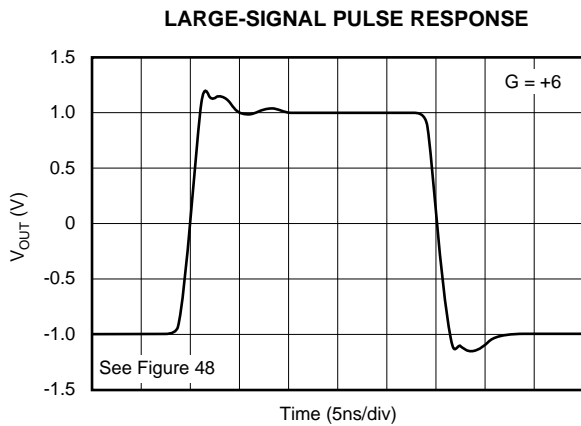

Figure 39.

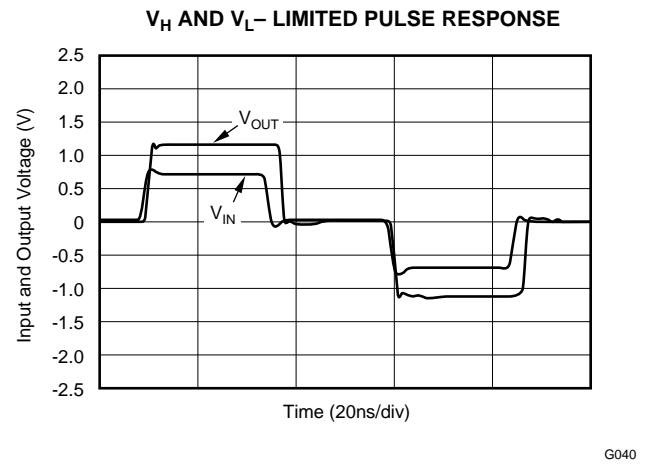

Figure 40.

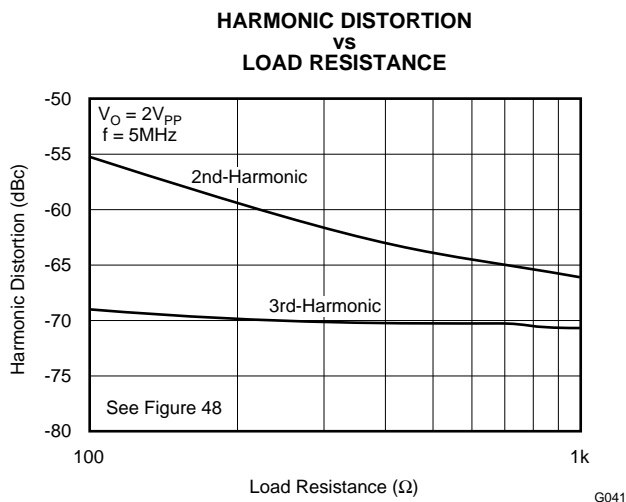

Figure 41.

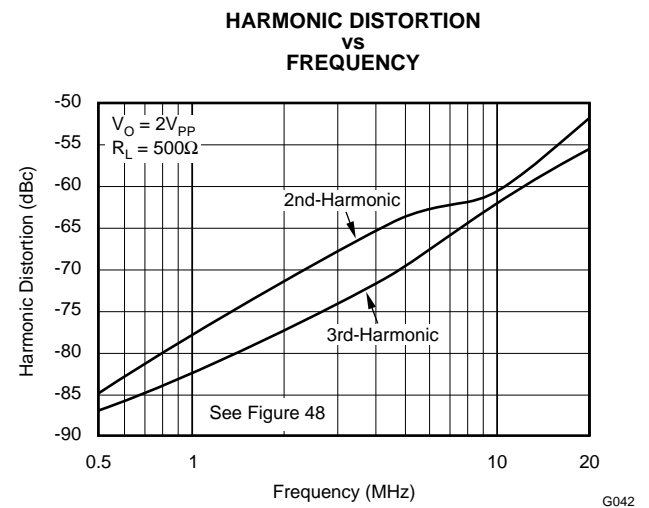

Figure 42.

TYPICAL CHARACTERISTICS $V_S = +5\text{ V}$ (continued)

$T_A = 25^\circ\text{C}$, $G = +6$, $R_F = 750\ \Omega$, and $R_L = 500\ \Omega$ to $V_{CM} = +2.5\text{ V}$, $V_L = V_{CM} - 1.2\text{ V}$, $V_H = V_{CM} + 1.2\text{ V}$, unless otherwise noted

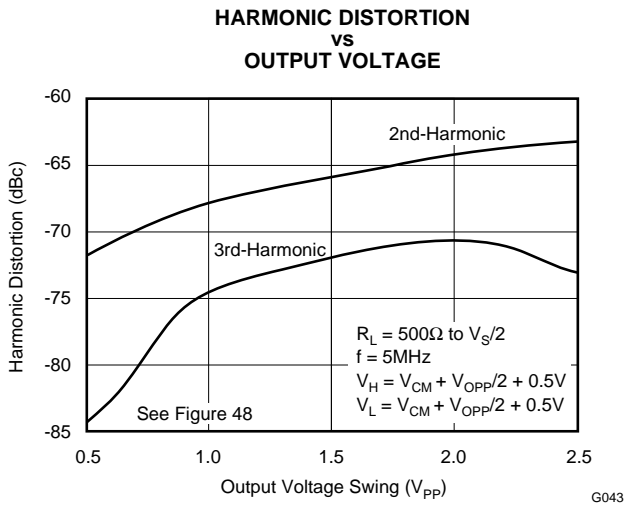

Figure 43.

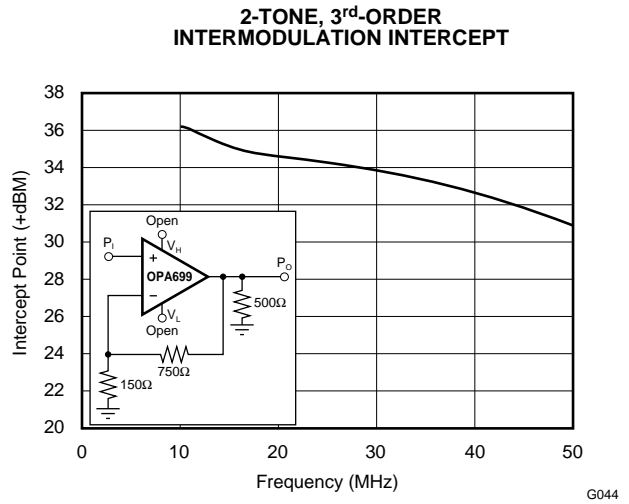

Figure 44.

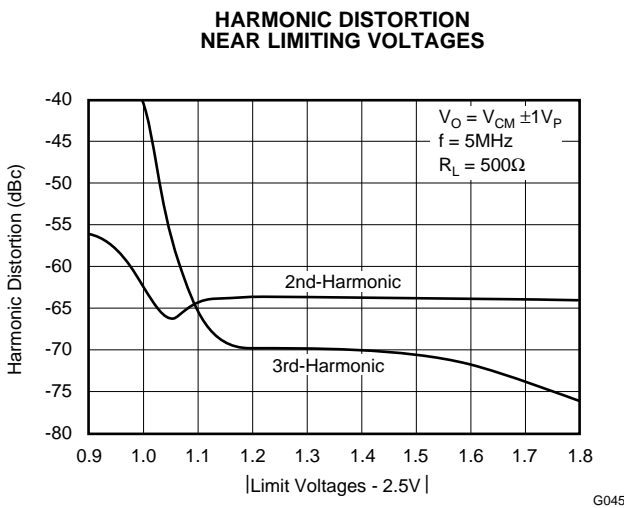

Figure 45.

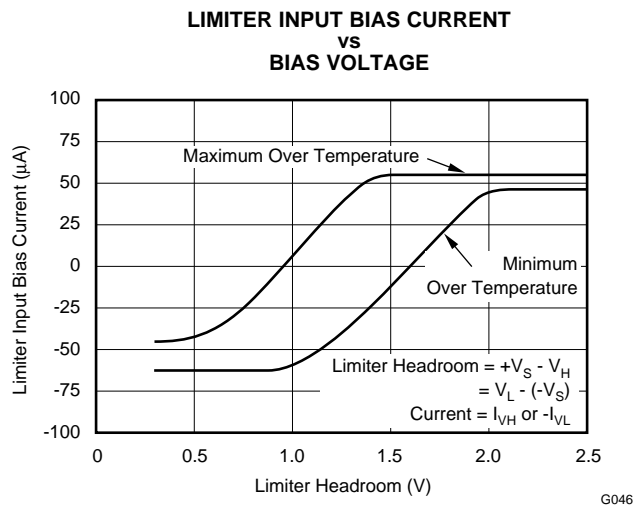

Figure 46.

APPLICATION INFORMATION

DUAL-SUPPLY, NON-INVERTING AMPLIFIER

The OPA699 is a +4 V/V minimum gain voltage-feedback amplifier that combines features of a wideband, high slew rate amplifier with output voltage limiters. Its output can swing up to 1 V from each rail and can deliver up to 120 mA. These capabilities make it an ideal interface to drive an ADC while adding overdrive protection for the ADC inputs.

Figure 47 shows the ac-coupled, gain of +6 V/V, dual power-supply circuit configuration used as the basis of the ± 5 -V Electrical Characteristics and Typical Characteristics. For test purposes, the input impedance is set to 50 Ω with a resistor to ground and the output is set to 500 Ω . Voltage swings reported in the specifications are taken directly at the input and output pins. For the circuit of Figure 47, the total output load will be 500 Ω || 900 Ω = 321 Ω . The voltage limiting pins are set to ± 2 V through a voltage divider network between $+V_S$ and ground for V_H and between $-V_S$ and ground for V_L . These limiter voltages are adequately bypassed with a 0.1- μ F ceramic capacitor to ground. The limiter voltages (V_H and V_L) and the respective bias currents (I_{VH} and I_{VL}) have the polarities shown. One additional component is included in Figure 47. An additional resistor (100 Ω) is included in series with the noninverting input. Combined with the 25- Ω dc source resistance looking back towards the signal generator, this gives an input bias current-canceling resistance that matches the 125- Ω source resistance seen at the inverting input (see the dc accuracy and offset control section). The power-supply bypass for each supply consists of two capacitors: one electrolytic 2.2 μ F and one ceramic 0.1 μ F. The power-supply bypass capacitors are shown explicitly in Figure 47 and Figure 48, but will be assumed in the other figures. An additional 0.01- μ F power-supply decoupling capacitor (not shown here) can be included between the two power-supply pins. In practical PC board layouts, this optional, added capacitor typically improves the 2nd harmonic distortion performance by 3 dB to 6 dB.

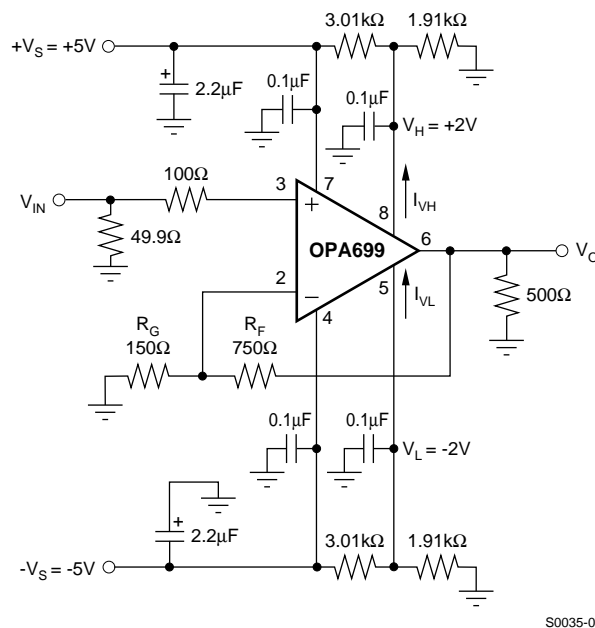

Figure 47. DC-Coupled, Dual Supply Amplifier

SINGLE-SUPPLY, NON-INVERTING AMPLIFIER

Figure 48 shows an ac-coupled, noninverting gain amplifier for single +5-V supply operation. This circuit was used for ac characterization of the OPA699, with a 50- Ω source (which it matches) and a 500- Ω load. The mid-point reference on the noninverting input is set by two 1.5-k Ω resistors. This gives an input bias current-canceling resistance that matches the 750- Ω dc source resistance seen at the inverting input (see the dc accuracy and offset control section). The power-supply bypass for the supply consists of two capacitors: one electrolytic 2.2 μ F and one ceramic 0.1 μ F. The power-supply bypass capacitors are shown explicitly in Figure 47

APPLICATION INFORMATION (continued)

and Figure 48, but will be assumed in the other figures. The limiter voltages (V_H and V_L) and the respective bias currents (I_{VH} and I_{VL}) have the polarities shown. These limiter voltages are adequately bypassed with a 0.1- μ F ceramic capacitor to ground. Notice that the single-supply circuit can use three resistors to set V_H and V_L , where the dual-supply circuit usually uses four to reference the limit voltages to ground. While this circuit shows +5-V operation, the same circuit may be used for single supplies up to +12 V.

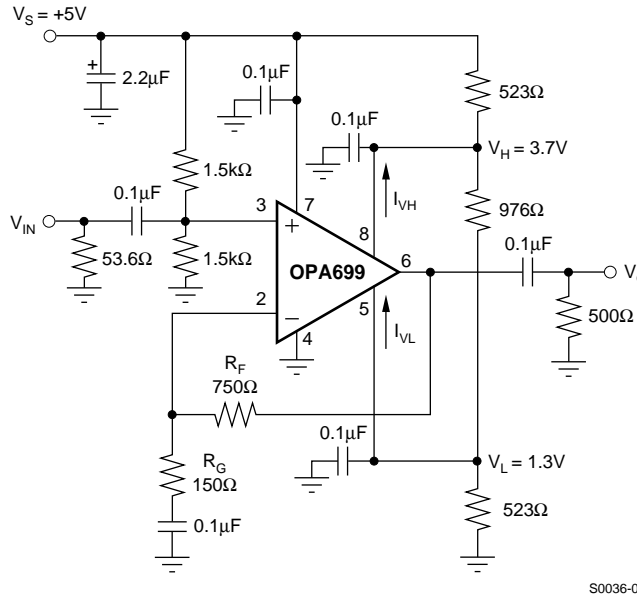

Figure 48. AC-Coupled, Single Supply Amplifier

WIDEBAND INVERTING OPERATION

Operating the OPA699 as an inverting amplifier has several benefits and is particularly useful when a matched 50- Ω source and input impedance are required. Figure 49 shows the inverting gain of -4 V/V circuit used as the basis of the inverting mode typical characteristics.

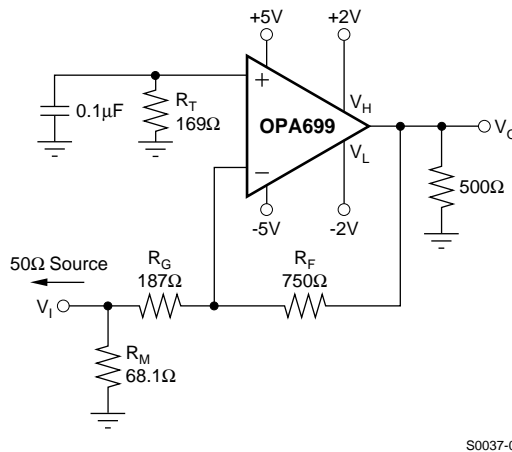

Figure 49. Inverting $G = -4$ Specifications and Test Circuit

In the inverting case, only the feedback resistor appears as part of the total output load in parallel with the actual load. For a 500- Ω load used in the typical characteristics, this gives a total load of 329 Ω in this inverting

APPLICATION INFORMATION (continued)

configuration. The gain resistor is set to get the desired gain (in this case, 187 Ω for a gain of -4) while an additional input resistor (R_M) can be used to set the total input impedance equal to the source, if desired. In this case, $R_M = 68.1 \Omega$ in parallel with the 187- Ω gain setting resistor gives a matched input impedance of 50 Ω . This matching is only needed when the input needs to be matched to a source impedance, as in the characterization testing done using the circuit of Figure 49.

For bias current-cancellation matching, the noninverting input requires a 169- Ω resistor to ground. The calculation for this resistor includes a dc-coupled 50- Ω source impedance along with R_G and R_M . Although this resistor provides cancellation for the bias current, it must be well-decoupled (0.1 μF in Figure 49) to filter the noise contribution of the resistor and the input current noise.

As the required R_G resistor approaches 50 Ω at higher gains, the bandwidth for the circuit in Figure 49 far exceeds the bandwidth at that same gain magnitude for the noninverting circuit of Figure 47. This occurs due to the lower noise gain for the circuit of Figure 49 when the 50- Ω source impedance is included in the analysis. For instance, at a signal gain of -15 ($R_G = 50 \Omega$, $R_M = \text{open}$, $R_F = 750 \Omega$) the noise gain for the circuit of Figure 49 will be $1 + 750 \Omega / (50 \Omega + 50 \Omega) = 8.5$ due to the addition of the 50- Ω source in the noise gain equation. This approach gives considerably higher bandwidth than the noninverting gain of $+15$. Using the 1-GHz gain bandwidth product for the OPA699, an inverting gain of -15 from a 50- Ω source to a 50- Ω R_G gives 140-MHz bandwidth, whereas the noninverting gain of $+6$ gives 55 MHz, as shown in the measured results of Figure 50.

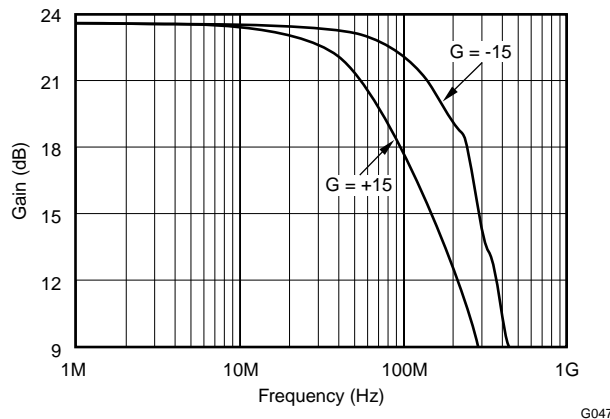

Figure 50. G = +15 and -15 Frequency Response

LOW-GAIN COMPENSATION FOR IMPROVED SFDR

Where a low gain is desired and inverting operation is acceptable, a new external compensation technique can be used to retain the full slew rate and noise benefits of the OPA699, while giving increased loop gain and the associated distortion improvements offered by a non-unity-gain stable op amp. This technique shapes the loop gain for good stability, while giving an easily controlled 2nd-order low-pass frequency response. To set the compensation capacitors (C_S and C_F), consider the half-circuit of Figure 51, where the 50- Ω source is used.

Considering only the noise gain for the circuit of Figure 51, the low-frequency noise gain (N_{G1}) is set by the resistor ratio, while the high-frequency noise gain (N_{G2}) is set by the capacitor ratio. The capacitor values set both the transition frequencies and the high-frequency noise gain. If the high-frequency noise gain, determined by $N_{G2} = 1 + C_S/C_F$, is set to a value greater than the recommended minimum stable gain for the op amp, and the noise gain pole (set by $1/R_FC_F$) is placed correctly, a well controlled 2nd-order low-pass frequency response results.

APPLICATION INFORMATION (continued)

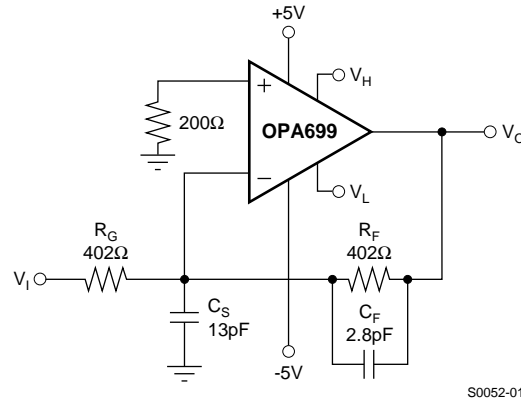

Figure 51. Broadband, Low-Inverting Gain External Compensation

To choose the values for both C_S and C_F , two parameters and only three equations need to be solved. The first parameter is the target high-frequency noise gain (N_{G2}), which should be greater than the minimum stable gain for the OPA699. Here, a target of $N_{G2} = 26$ is used. The second parameter is the desired low-frequency signal gain, which also sets the low-frequency noise gain (N_{G1}). To simplify this discussion, we target a maximally flat 2nd-order low-pass Butterworth frequency response ($Q = 0.707$). The signal gain shown in Figure 51 sets the low-frequency noise gain to $N_{G1} = 1 + R_F/R_G (= 2$ in this example). Then, using only these two gains and the gain bandwidth product for the OPA699 (1000 MHz), the key frequency in the compensation is set by Equation 1.

$$Z_O = \frac{GBP}{NG_1^2} \left[\left(1 - \frac{N_{G1}}{N_{G2}} \right) - \sqrt{1 - 2 \frac{N_{G1}}{N_{G2}}} \right] \quad (1)$$

Physically, this Z_O (22.3 MHz for the values shown above) is set by $1/[2\pi R_F(C_F + C_S)]$ and is the frequency at which the rising portion of the noise gain would intersect the unity gain if projected back to a 0 dB gain. The actual zero in the noise gain occurs at $N_{G1} \times Z_O$ and the pole in the noise gain occurs at $N_{G2} \times Z_O$. That pole is physically set by $1/(R_F C_F)$. Since GBP is expressed in Hz, multiply Z_O by 2π and use to get C_F by solving Equation 2.

$$C_F = \frac{1}{2\pi R_F Z_O N_{G2}} (= 3 \text{ pF}) \quad (2)$$

Finally, since C_S and C_F set the high-frequency noise gain, determine C_S using Equation 3 (solving for C_S by using $N_{G2} = 6$):

$$C_S = (N_{G2} - 1) C_F \quad (3)$$

which gives $C_S = 15 \text{ pF}$.

Both of these calculated values have been reduced slightly in Figure 51 to account for parasitics. The resulting closed-loop bandwidth is approximately equal to Equation 4.

$$f_{-3dB} \equiv \sqrt{Z_O - GBP} \quad (4)$$

For the values shown in Figure 51, $f_{-3 \text{ dB}}$ is approximately 149 MHz. This is less than that predicted by simply dividing the GBP product by N_{G1} . The compensation network controls the bandwidth to a lower value, while providing the full slew rate at the output and an improved distortion performance due to increased loop gain at frequencies below $N_{G1} \times Z_O$.

APPLICATION INFORMATION (continued)

LOW DISTORTION, LIMITED OUTPUT, ADC INPUT DRIVER

Figure 52 shows a simple ADC driver that operates on a single supply, and gives excellent distortion performance. The limit voltages track the input range of the converter, completely protecting against input overdrive. Note that the limiting voltages have been set 100 mV above/below the corresponding reference voltage from the converter. This circuit also implements an improved distortion for an inverting gain of -2 using external compensation.

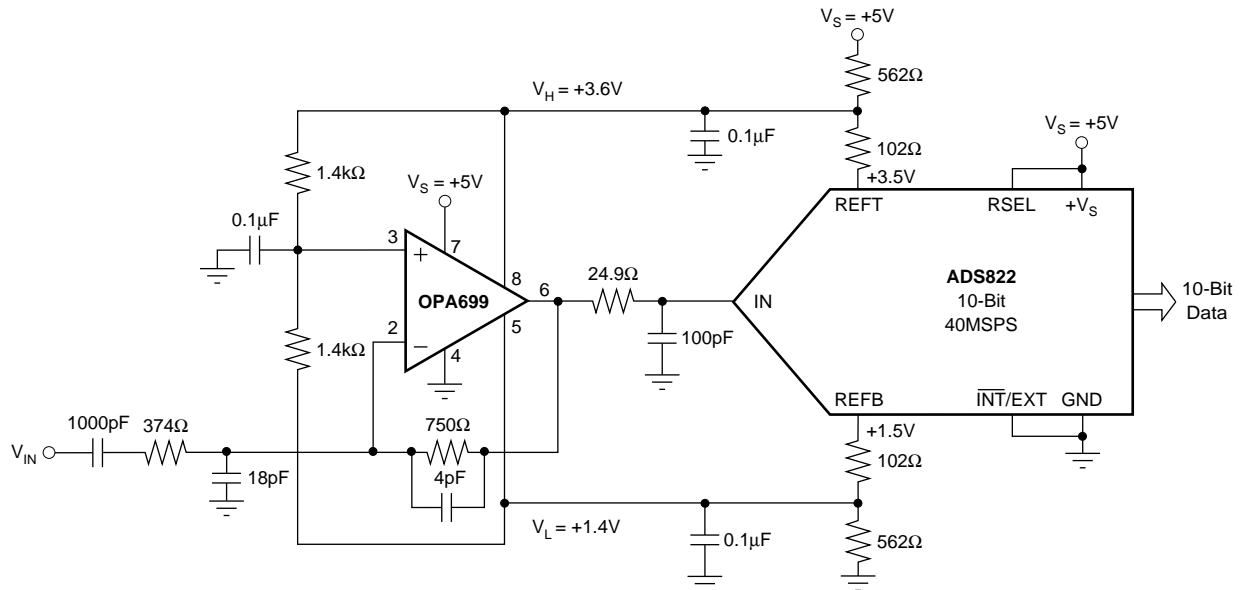

S0038-02

Figure 52. Single Supply, Limiting ADC Input Driver

LIMITED OUTPUT, DIFFERENTIAL ADC INPUT DRIVER

Figure 53 shows a differential ADC driver that takes advantage of the OPA699 limiters to protect the input of the ADC. Two OPA699s are used. The first one is an inverting configuration at a gain of -2 . The second one is in a noninverting configuration at a gain of $+2$. See the *Low Gain Compensation for Improved SFDR* section for a discussion of stability issues of the OPA699 operating at a gain less than four. Each amplifier is swinging $2 V_{PP}$ providing a $4-V_{PP}$ differential signal to drive the input of the ADC. Limiters have been set 100 mV away from the magnitude of each amplifier maximum signal to provide input protection for the ADC, while maintaining an acceptable distortion level.

APPLICATION INFORMATION (continued)

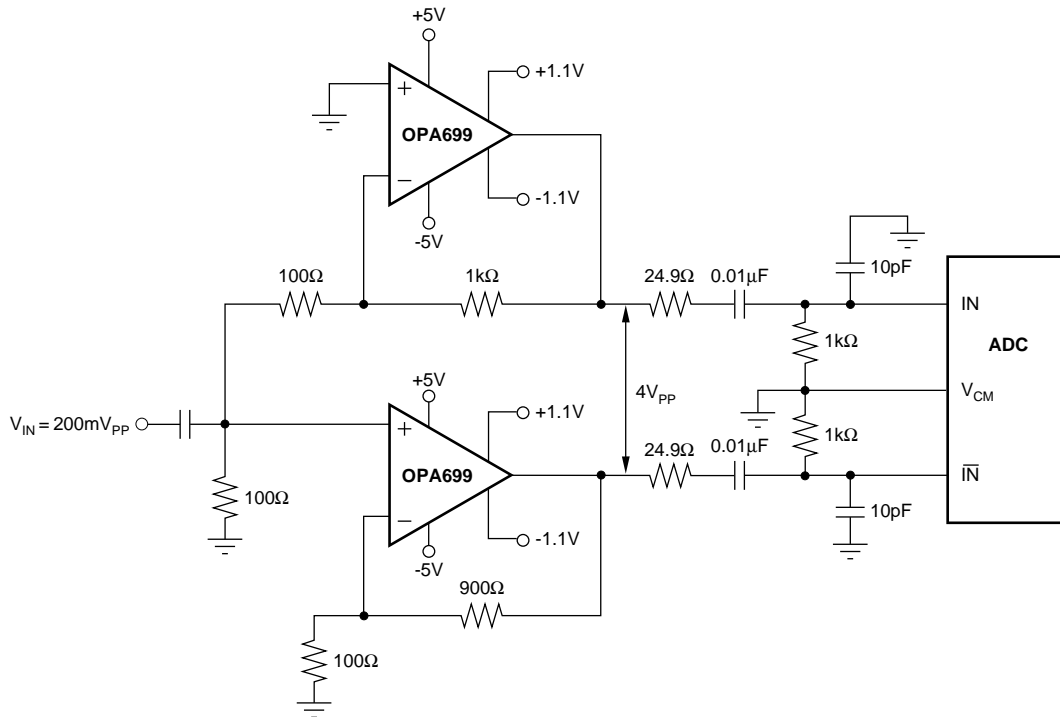

S0040-02

Figure 53. Single to Differential AC-Coupled, High Gain Output Limited ADC Driver

PRECISION HALF-WAVE RECTIFIER

Figure 54 shows a half-wave rectifier with outstanding precision and speed. V_H (pin 8) defaults to 3.5 V typically if left open, while the negative limit is set to ground.

The gain for the circuit in Figure 54 is set at +6. Figure 55 shows input and output for ± 0.5 V 100-MHz input.

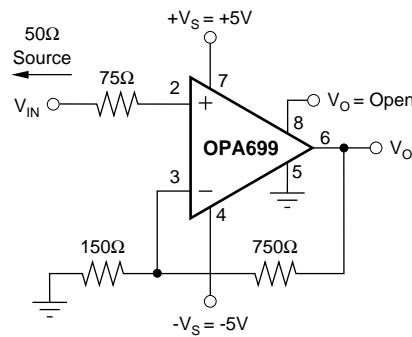

S0039-02

Figure 54. Precision Half-Wave Rectifier

APPLICATION INFORMATION (continued)

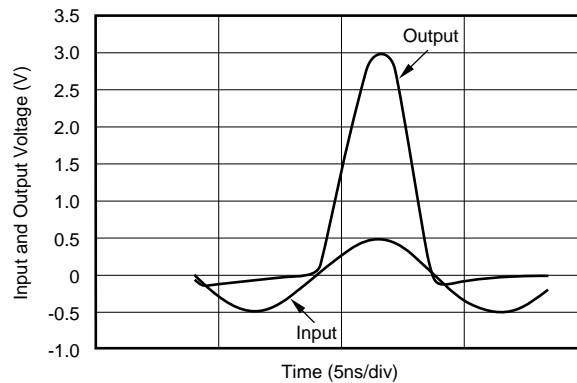

G048

Figure 55. 100-MHz Sinewave Rectified

HIGH-SPEED Schmitt TRIGGER

Figure 56 shows a high-speed Schmitt Trigger. The output levels are precisely defined and the switching time is exceptional. The output voltage swings between V_H and V_L .

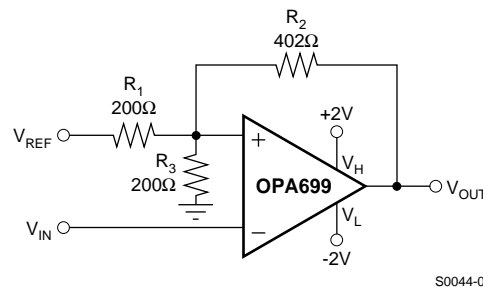

S0044-02

Figure 56. High-Speed Schmitt Trigger

The circuit operates as follows. When the input voltage is less than V_{HL} then the output is limiting at V_H . When the input is greater than V_{HH} , then the output is limiting at V_L , with V_{HL} and V_{HH} defined as in Equation 5.

$$V_{HL,HH} = \left(\frac{R1 \parallel R2 \parallel R3}{R1} \times V_{ref} \right) + \left(\frac{R1 \parallel R2 \parallel R3}{R2} \times V_{OUT} \right) \quad (5)$$

Due to the inverting function realized by the Schmitt Trigger, V_{HL} corresponds to $V_{OUT} = V_H$, and V_{HH} corresponds to $V_{OUT} = V_L$.

Figure 57 shows the Schmitt Trigger operating with $V_{REF} = +5$ V. This gives us $V_{HH} = 2.4$ V and $V_{HL} = 1.6$ V. The propagation delay for the OPA699 in a Schmitt Trigger configuration is 4 ns from high-to-low and 4 ns from low-to-high.

APPLICATION INFORMATION (continued)

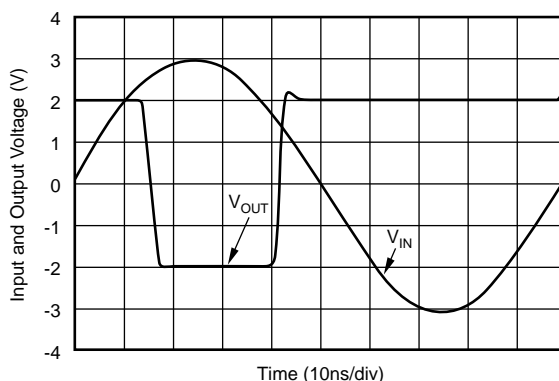

G049

Figure 57. Schmitt Trigger Time Domain Response for a 10-MHz Sinewave

DESIGN-IN TOOLS

Applications Support

The Texas Instruments Applications Department is available for design assistance at 1-972-644-5580. The Texas Instruments web site (www.ti.com) has the latest product data sheets and other design tools.

Demonstration Boards

A PC board is available to assist in the initial evaluation of circuit performance of the OPA699ID. It is available as an unpopulated PCB with descriptive documentation, and can be requested through the Texas Instruments web site. See the demonstration board literature for more information. The summary information for this board is shown in Table 1.

Table 1. Evaluation Module Ordering Information

PRODUCT	PACKAGE	BOARD PART NUMBER	LITERATURE NUMBER
OPA699ID	SO-8	DEM-OPA-SO-1A	SBOU009

OPERATING SUGGESTIONS

Theory of Operation

The OPA699 is a voltage-feedback, gain of +4 V/V stable op amp. The output voltage is limited to a range set by the voltage on the limiter pins (5 and 8). When the input tries to overdrive the output, the limiters take control of the output buffer. This action from the limiters avoids saturating any part of the signal path, giving quick overdrive recovery and excellent limiter accuracy at any signal gain. The limiters have a sharp transition from the linear region of operation to output limiting. This transition allows the limiter voltages to be set near (< 100 mV) the desired signal range. The distortion performance is also good near the limiter voltages.

Output Limiters

The output voltage is linearly dependent on the input(s) when it is between the limiter voltages V_H (pin 8) and V_L (pin 5). When the output tries to exceed V_H or V_L , the corresponding limiter buffer takes control of the output voltage and holds it at V_H or V_L . Because the limiters act on the output, their accuracy does not change with the gain. The transition from the linear region of operation to output limiting is sharp—the desired output signal can safely come to within 30 mV of V_H or V_L with no onset of non-linearity. The limiter voltages can be set to within 0.7 V of the supplies ($V_L = -V_S + 0.7$ V, $V_H = +V_S - 0.7$ V). They must also be at least 400 mV apart ($V_H - V_L = 0.4$ V). When pins 5 and 8 are left open, V_H and V_L go to the default voltage limit; the minimum values are given in the electrical specifications. Looking at [Figure 58](#) for the zero bias current case shows the expected range of (V_S — default limit voltages) = headroom.

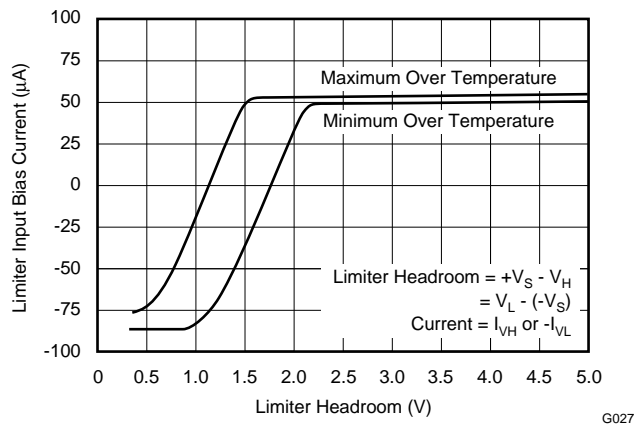

Figure 58. Limit Bias Current vs Bias Voltage

When the limiter voltages are more than 2.1 V from the supplies ($V_L = -V_S + 2.1$ V or $V_H = +V_S - 2.1$ V), you can use simple resistor dividers to set V_H and V_L (see Figure 47). Make sure to include the limiter input bias currents (see Figure 54) in the calculations (that is, $I_{VL} = 50$ μ A into pin 5, and $I_{VH} = +50$ μ A out of pin 8). For good limiter voltage accuracy, run a minimum 1-mA quiescent bias current through these resistors. When the limiter voltages need to be within 2.1 V of the supplies ($V_L = -V_S + 2.1$ V or $V_H = +V_S - 2.1$ V), consider using low impedance buffers to set V_H and V_L to minimize errors due to bias current uncertainty. This condition typically is the case for single-supply operation ($V_S = +5$ V). Figure 48 runs 2.5 mA through the resistive divider that sets V_H and V_L . This limits errors due to I_{VH} and $I_{VL} < \pm 1\%$ of the target limit voltages. The limiters' dc accuracy depends on attention to detail. The two dominant error sources can be improved as follows:

- Power supplies, when used to drive resistive dividers that set V_H and V_L , can contribute large errors (for example, $\pm 5\%$). Using a more accurate source and bypassing pins 5 and 8 with good capacitors, improves limiter PSRR.
- The resistor tolerances in the resistive divider can also dominate. Use 1% resistors. Other error sources also contribute, but should have little impact on the limiters' dc accuracy.
- Reduce offsets caused by the limiter input bias currents. Select the resistors in the resistive divider(s) as described above.
- Consider the signal path dc errors as contributing to uncertainty in the useable output swing.
- The limiter offset voltage only slightly degrades limiter accuracy. Figure 59 shows how the limiters affect distortion performance. Virtually no degradation in linearity is observed for output voltage swinging right up to the limiter voltages. In this plot a fixed ± 1 -V output swing is driven while the limiter voltages are reduced symmetrically. Until the limiters are reduced to ± 1.1 V, little distortion degradation is observed.

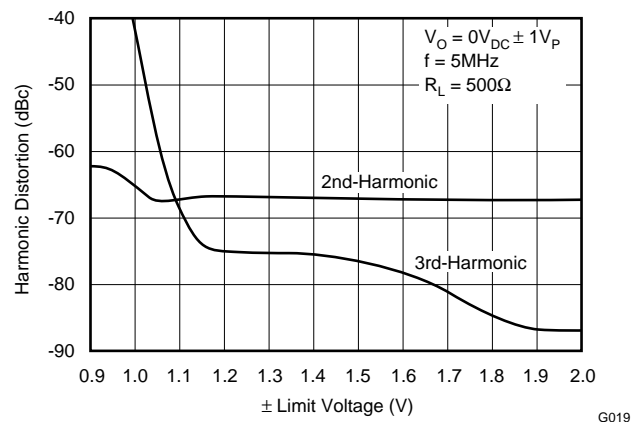

Figure 59. Harmonic Distortion Near Limit Voltages

Output Drive

The OPA699 has been optimized to drive 500-Ω loads, such as ADCs. It still performs well driving 100-Ω loads; the specifications are shown for the 500-Ω load. This makes the OPA699 an ideal choice for a wide range of high-frequency applications.

Many high-speed applications, such as driving ADCs, require op amps with low output impedance. As shown in the typical performance curve *Output Impedance vs Frequency*, the OPA699 maintains low closed-loop output impedance over frequency. Closed-loop output impedance increases with frequency, since loop gain decreases with frequency.

Thermal Considerations

The OPA699 does not require heat sinking under most operating conditions. Maximum desired junction temperature sets a maximum allowed internal power dissipation as described below. In no case should the maximum junction temperature be allowed to exceed 150°C.

The total internal power dissipation (P_D) is the sum of quiescent power (P_{DQ}) and the additional power dissipated in the output stage (P_{DL}), while delivering load power. P_{DQ} is simply the specified no-load supply current times the total supply voltage across the part. P_{DL} depends on the required output signals and loads. For a grounded resistive load, and equal bipolar supplies, it is at maximum when the output is at 1/2 either supply voltage. In this condition, $P_{DL} = V_S^2/(4R_L)$ where R_L includes the feedback network loading. Note that it is the power in the output stage and not in the load, that determines internal power dissipation.

The operating junction temperature is: $T_J = T_A + P_D \times \theta_{JA}$, where T_A is the ambient temperature. For example, the maximum T_J for a OPA699ID with $G = +6$, $R_F = 750 \Omega$, $R_L = 500 \Omega$, and $\pm V_S = \pm 5 \text{ V}$ at the maximum $T_A = 85^\circ\text{C}$ is calculated as:

$$P_{DQ} = (10 \text{ V} \times 15.5 \text{ mA}) = 155 \text{ mW}$$

$$P_{DL} = \frac{(5\text{V})^2}{4 \times (500 \Omega \parallel 900 \Omega)} = 19.4 \text{ mW}$$

$$P_D = 155 \text{ mW} + 19.4 \text{ mW} = 174.4 \text{ mW}$$

$$T_J = 85^\circ\text{C} + 174.4 \text{ mW} \times 125^\circ\text{C}/\text{W} = 107^\circ\text{C}$$

(6)

This would be the maximum T_J from $V_O = \pm 2.5 V_{DC}$. Most applications will be at a lower output stage power and have a lower T_J . Care must be taken when operating at higher ambient temperatures.

Capacitive Loads

Capacitive loads, such as the input to ADCs, decreases the amplifier phase margin, which may cause high-frequency peaking or oscillations. Capacitive loads $\geq 2 \text{ pF}$ should be isolated by connecting a small resistor in series with the output, as shown in Figure 60. Increasing the gain from +2 improves the capacitive drive capabilities due to increased phase margin.

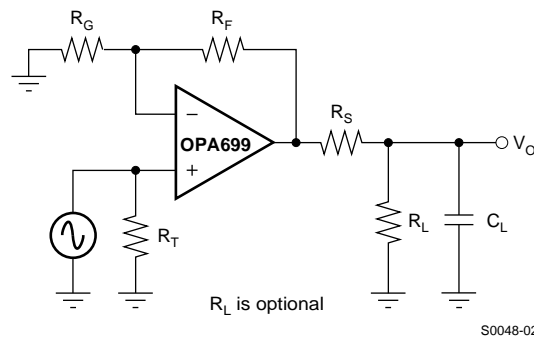

Figure 60. Driving Capacitive Loads

In general, capacitive loads should be minimized for optimum high-frequency performance. The capacitance of coax cable (29 pF/ft for RG-58) does not load the amplifier when the coaxial cable or transmission line is terminated in its characteristic impedance.

Frequency Response Compensation

The OPA699 is internally compensated to be +4 gain stable and has a nominal phase margin of 60° at a gain of +6. Phase margin and peaking improve at higher gains. Recall that an inverting gain of -5 is equivalent to a gain of +6 for bandwidth purposes (that is, noise gain = 6). Standard external compensation techniques work with this device. For example, in the inverting configuration, the bandwidth may be limited without modifying the inverting gain by placing a series RC network to ground on the inverting node. This has the effect of increasing the noise gain at high frequencies, which limits the bandwidth.

For unity-gain stable amplifier applications, the OPA698 is recommended.

In applications where a large feedback resistor is required, such as a photodiode transimpedance amplifier, the parasitic capacitance from the inverting input to ground causes peaking or oscillations. To compensate for this effect, connect a small capacitor in parallel with the feedback resistor. The bandwidth is limited by the pole that the feedback resistor and this capacitor create. In other high-gain applications, use a three-resistor *Tee* network to reduce the RC time constants set by the parasitic capacitances.

Pulse Settling Time

The OPA699 is capable of an extremely fast settling time in response to a pulse input. Frequency response flatness and phase linearity are needed to obtain the best settling times. For capacitive loads, such as an ADC, use the recommended R_S in the typical performance curve *Recommended R_S vs Capacitive Load*. Extremely fine-scale settling (0.01%) requires close attention to ground return current in the supply decoupling capacitors.

The pulse settling characteristics, when recovering from overdrive, are extremely good as shown in the typical characteristics.

Distortion

The OPA699's distortion performance is specified for a 500- Ω load, such as an ADC. Driving loads with smaller resistance increases the distortion as illustrated in [Figure 61](#). Remember to include the feedback network in the load resistance calculations.

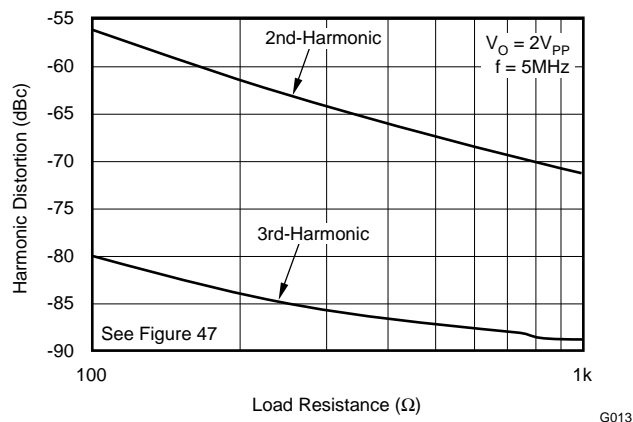

Figure 61. 5-MHz Harmonic Distortion vs Load Resistance

Noise Performance

High slew rate, voltage-feedback op amps usually achieve their slew rate at the expense of a higher input noise voltage. The 4.1-nV/ $\sqrt{\text{Hz}}$ input voltage noise for the OPA699, however, is much lower than comparable amplifiers. The input-referred voltage noise and the two input-referred current noise terms, combine to give low output noise under a wide variety of operating conditions. [Figure 62](#) shows the op amp noise analysis model with all the noise terms included. In this model, all noise terms are taken to be noise voltage or current density terms in either nV/ $\sqrt{\text{Hz}}$ or pA/ $\sqrt{\text{Hz}}$.

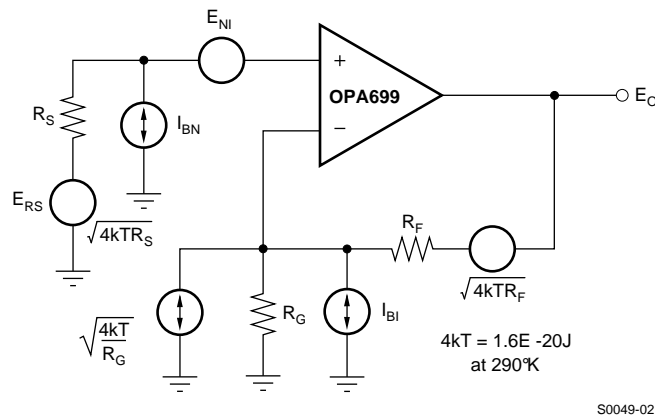

Figure 62. Op Amp Noise Analysis Model

The total output spot noise voltage can be computed as the square root of the sum of all squared output noise voltage contributors. Equation 7 shows the general form for the output noise voltage using the terms shown in Figure 62.

$$E_O = \sqrt{\left(E_{NI}^2 + (I_{BN}R_S)^2 + 4kTR_S\right)NG^2 + \left(I_{BI}R_F\right)^2 + 4kTR_FNG} \quad (7)$$

Dividing this expression by the noise gain $[NG = (1+R_F/R_G)]$ gives the equivalent input-referred spot noise voltage at the noninverting input, as shown in Equation 8.

$$E_N = \sqrt{E_{NI}^2 + (I_{BN}R_S)^2 + 4kTR_S + \left(\frac{I_{BI}R_F}{NG}\right)^2 + \frac{4kTR_F}{NG}} \quad (8)$$

Evaluating these two equations for the OPA699 circuit and component values (see Figure 47) gives a total output spot noise voltage of 27.4 nV/√Hz and a total equivalent input spot noise voltage of 4.6 nV/√Hz. This total input-referred spot noise voltage is only slightly higher than the 4.1-nV/√Hz specification for the op amp voltage noise alone. This is the case as long as the impedances appearing at each op amp input are limited to a maximum value of 300 Ω. Keeping both $(R_F \parallel R_G)$ and the noninverting input source impedance less than 300 Ω satisfies both noise and frequency response flatness considerations. Since the resistor-induced noise is negligible, additional capacitive decoupling across the bias current cancellation resistor (R_T) for the inverting op amp configuration of Figure 49 is not required, but is still desirable.

DC-Accuracy and Offset Control

The balanced input stage of a wideband voltage feedback op amp allows good output dc accuracy in a large variety of applications. The power-supply current trim for the OPA699 gives even tighter control than comparable products. Although the high-speed input stage does require relatively high input bias current (typically 3 μA at each input terminal), the close matching between them may be used to reduce the output dc error caused by this current. The total output offset voltage may be considerably reduced by matching the dc source resistances appearing at the two inputs. This reduces the output dc error due to the input bias currents to the offset current times the feedback resistor. Evaluating the configuration of Figure 47, using worst-case +25°C input offset voltage and current specifications, gives a worst-case output offset voltage, with $NG =$ noninverting signal gain, equal to:

$$\begin{aligned} & \pm[NG \times V_{IO(MAX)}] \pm [R_F \times I_{IO(MAX)}] \\ & = \pm(2 \times 8 \text{ mV}) \pm (750 \Omega \times 3 \mu\text{A}) \\ & = \pm 18.3 \text{ mV} \end{aligned}$$

A fine-scale output offset null or dc operating point adjustment, is often required. Numerous techniques are available for introducing dc-offset control into an op amp circuit. Most of these techniques eventually reduce to adding a dc current through the feedback resistor. In selecting an offset trim method, one key consideration is the impact on the desired signal path frequency response. If the signal path is intended to be noninverting, the offset control is best applied as an inverting summing signal to avoid interaction with the signal source. If the signal path is intended to be inverting, applying the offset control to the noninverting input may be considered. However, the dc offset voltage on the summing junction sets up a dc current back into the source which must be considered. Applying an offset adjustment to the inverting op amp input can change the noise gain and frequency response flatness. For a dc-coupled inverting amplifier, Figure 63 shows one example of an offset adjustment technique that has minimal impact on the signal frequency response. In this case, the dc offsetting current is brought into the inverting input node through resistor values that are much larger than the signal path resistors. This insures that the adjustment circuit has minimal effect on the loop gain as well as the frequency response.

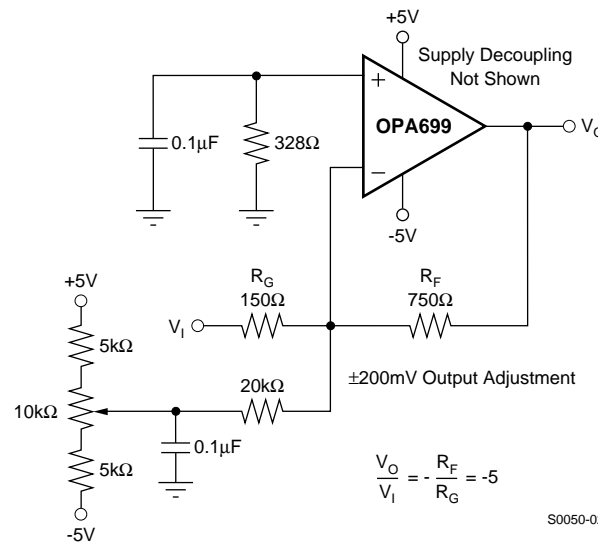

Figure 63. DC-Coupled, Inverting Gain of –5, With Offset Adjustment

Board Layout Guidelines

Achieving optimum performance with the high-frequency OPA699 requires careful attention to layout design and component selection. Recommended PCB layout techniques and component selection criteria are:

1. **Minimize parasitic capacitance to any ac ground** for all of the signal I/O pins. Open a window in the ground and power planes around the signal I/O pins, and leave the ground and power planes unbroken elsewhere.
2. **Provide a high quality power supply.** Use linear regulators, ground plane and power planes to provide power. Place high frequency 0.1-μF decoupling capacitors < 0.2" away from each power-supply pin. Use wide, short traces to connect to these capacitors to the ground and power planes. Also use larger (2.2 μF to 6.8 μF) high-frequency decoupling capacitors to bypass lower frequencies. They may be somewhat further from the device and be shared among several adjacent devices.
3. **Place external components close** to the OPA699. This minimizes inductance, ground loops, transmission line effects and propagation delay problems. Be extra careful with the feedback (R_F), input and output resistors.
4. **Use high-frequency components** to minimize parasitic elements. Resistors should be a low reactance type. Surface-mount resistors work best and allow a tighter layout. Metal film or carbon composition axially-leaded resistors can also provide good performance when their leads are as short as possible. Never use wirewound resistors for high-frequency applications. Remember that most potentiometers have large parasitic capacitances and inductances. Multilayer ceramic chip capacitors work best and take up little space. Monolithic ceramic capacitors also work well. Use R_F type capacitors with low ESR and ESL. The large power pin bypass capacitors (2.2 μF to 6.8 μF) should be tantalum for better high frequency and pulse performance.

5. **Choose low resistor values** to minimize the time constant set by the resistor and its parasitic parallel capacitance. Good metal film or surface mount resistors have approximately 0.2-pF parasitic parallel capacitance. For resistors > 1.5 k Ω , this adds a pole and/or zero below 500 MHz. Make sure that the output loading is not too heavy. The recommended 750- Ω feedback resistor is a good starting point in most designs.
6. **Use short direct traces to other wideband devices** on the board. Short traces act as a lumped capacitive load. Wide traces (50 to 100 mils) should be used. Estimate the total capacitive load at the output and use the series isolation resistor recommended in the typical performance curve, *Recommended R_S vs Capacitive Load*. Parasitic loads < 2 pF may not need the isolation resistor.
7. **When long traces are necessary**, use transmission line design techniques (consult an ECL design handbook for microstrip and stripline layout techniques). A 50- Ω transmission line is not required on board—a higher characteristic impedance helps reduce output loading. Use a matching series resistor at the output of the op amp to drive a transmission line and a matched load resistor at the other end to make the line appear as a resistor. If the 6 dB of attenuation that the matched load produces is not acceptable, and the line is not too long, use the series resistor at the source only. This isolates the source from the reactive load presented by the line, but the frequency response will be degraded. Multiple destination devices are best handled as separate transmission lines, each with its own series source and shunt load terminations. Any parasitic impedances acting on the terminating resistors alters the transmission line match and can cause unwanted signal reflections and reactive loading.
8. **Do not use sockets** for high-speed parts like the OPA699. The additional lead length and pin-to-pin capacitance introduced by the socket creates an extremely troublesome parasitic network. Best results are obtained by soldering the part onto the board.

Power Supplies

The OPA699 is nominally specified for operation using either ± 5 -V supplies or a single +5-V supply. The maximum specified total supply voltage of 12 V allows reasonable tolerances on the supplies. Higher supply voltages can break down internal junctions, possibly leading to catastrophic failure. Single-supply operation is possible as long as common mode voltage constraints are observed. The common-mode input and output voltage specifications can be interpreted as required headroom to the supply voltage. Observing this input and output headroom requirement allows a design of non-standard or single-supply operation circuits. Figure 48 shows one approach to single-supply operation.

input and ESD protection

The OPA699 is built using a high-speed complementary bipolar process. The internal junction breakdown voltages are relatively low for these small geometry devices. These breakdowns are reflected in the *Absolute Maximum Ratings* table. All device pins are protected with internal ESD protection diodes to the power supplies, as shown in Figure 64.

These diodes provide moderate protection to input overdrive voltages above the supplies as well. The protection diodes can typically support 30-mA continuous current. Where higher currents are possible (e.g., in systems with ± 15 -V supply parts driving into the OPA699), current limiting series resistors should be added into the two inputs. Keep these resistor values as low as possible, since high values degrade both noise performance and frequency response.

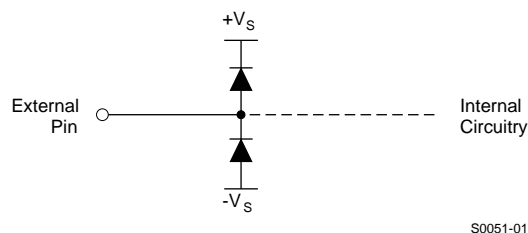

Figure 64. I/O Pin ESD Protection

PACKAGING INFORMATION

Orderable Device	Status (1)	Package Type	Package Drawing	Pins	Package Qty	Eco Plan (2)	Lead finish/ Ball material (6)	MSL Peak Temp (3)	Op Temp (°C)	Device Marking (4/5)	Samples
OPA699MJD	ACTIVE	CDIP SB	JD	8	45	Non-RoHS & Green	SNPB	N / A for Pkg Type	-55 to 125	OPA699MJD	Samples

(1) The marketing status values are defined as follows:

ACTIVE: Product device recommended for new designs.

LIFEBUY: TI has announced that the device will be discontinued, and a lifetime-buy period is in effect.

NRND: Not recommended for new designs. Device is in production to support existing customers, but TI does not recommend using this part in a new design.

PREVIEW: Device has been announced but is not in production. Samples may or may not be available.

OBsolete: TI has discontinued the production of the device.

(2) **RoHS:** TI defines "RoHS" to mean semiconductor products that are compliant with the current EU RoHS requirements for all 10 RoHS substances, including the requirement that RoHS substance do not exceed 0.1% by weight in homogeneous materials. Where designed to be soldered at high temperatures, "RoHS" products are suitable for use in specified lead-free processes. TI may reference these types of products as "Pb-Free".

RoHS Exempt: TI defines "RoHS Exempt" to mean products that contain lead but are compliant with EU RoHS pursuant to a specific EU RoHS exemption.

Green: TI defines "Green" to mean the content of Chlorine (Cl) and Bromine (Br) based flame retardants meet JS709B low halogen requirements of <=1000ppm threshold. Antimony trioxide based flame retardants must also meet the <=1000ppm threshold requirement.

(3) MSL, Peak Temp. - The Moisture Sensitivity Level rating according to the JEDEC industry standard classifications, and peak solder temperature.

(4) There may be additional marking, which relates to the logo, the lot trace code information, or the environmental category on the device.

(5) Multiple Device Markings will be inside parentheses. Only one Device Marking contained in parentheses and separated by a "~" will appear on a device. If a line is indented then it is a continuation of the previous line and the two combined represent the entire Device Marking for that device.

(6) Lead finish/Ball material - Orderable Devices may have multiple material finish options. Finish options are separated by a vertical ruled line. Lead finish/Ball material values may wrap to two lines if the finish value exceeds the maximum column width.

Important Information and Disclaimer:The information provided on this page represents TI's knowledge and belief as of the date that it is provided. TI bases its knowledge and belief on information provided by third parties, and makes no representation or warranty as to the accuracy of such information. Efforts are underway to better integrate information from third parties. TI has taken and continues to take reasonable steps to provide representative and accurate information but may not have conducted destructive testing or chemical analysis on incoming materials and chemicals. TI and TI suppliers consider certain information to be proprietary, and thus CAS numbers and other limited information may not be available for release.

In no event shall TI's liability arising out of such information exceed the total purchase price of the TI part(s) at issue in this document sold by TI to Customer on an annual basis.

OTHER QUALIFIED VERSIONS OF OPA699M :

- Catalog : [OPA699](#)

NOTE: Qualified Version Definitions:

- Catalog - TI's standard catalog product

JD (R-CDIP-T**)

CERAMIC SIDE-BRAZE DUAL-IN-LINE PACKAGE

20 PINS SHOWN

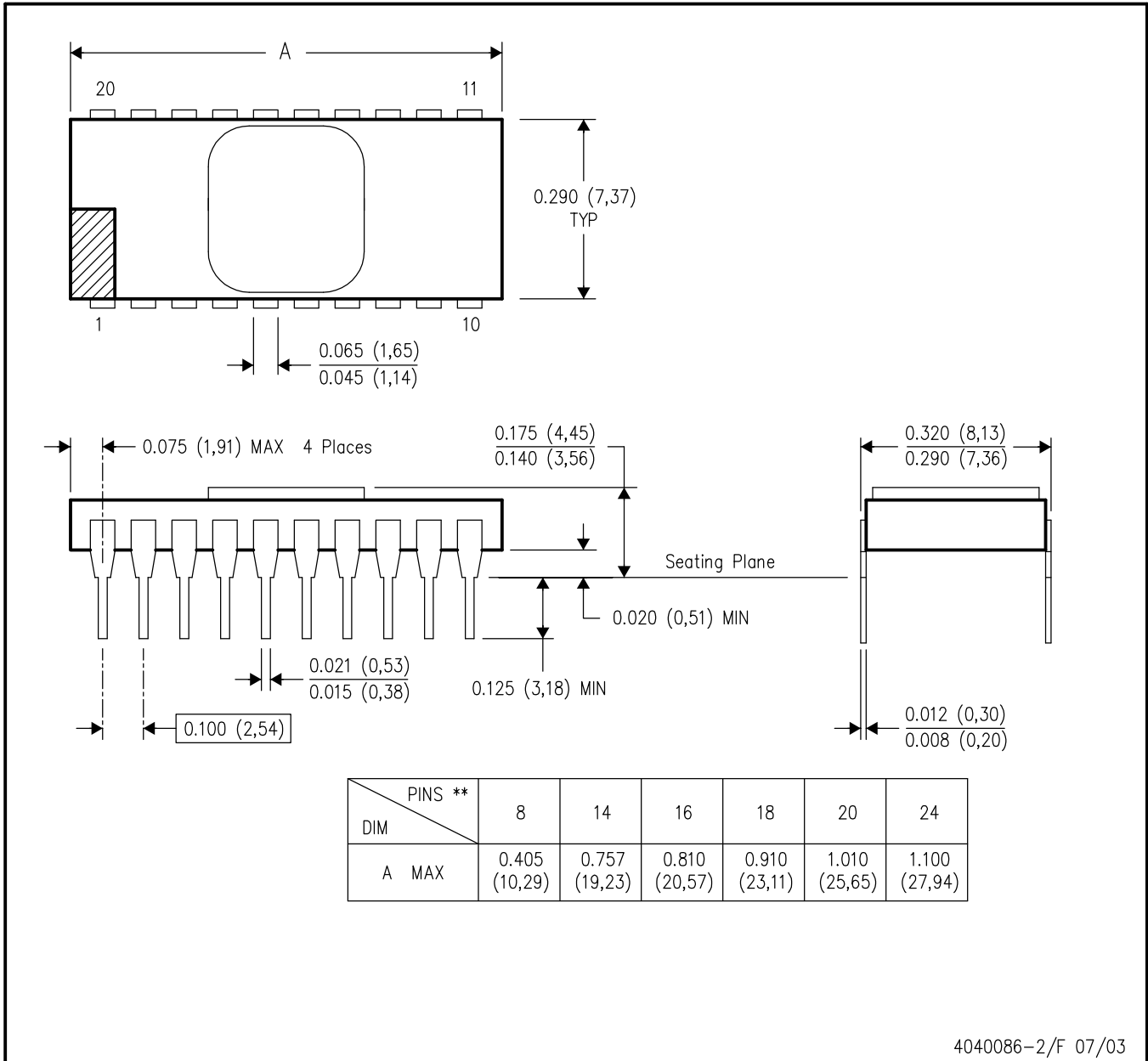

- NOTES:
- A. All linear dimensions are in inches (millimeters).
 - B. This drawing is subject to change without notice.
 - C. This package is hermetically sealed with a metal lid.
 - D. The terminals are gold plated.
 - E. Falls within MIL STD 1835 CDIP2 - T8, T14, T16, T18, T20 and T24 respectively.

IMPORTANT NOTICE AND DISCLAIMER

TI PROVIDES TECHNICAL AND RELIABILITY DATA (INCLUDING DATA SHEETS), DESIGN RESOURCES (INCLUDING REFERENCE DESIGNS), APPLICATION OR OTHER DESIGN ADVICE, WEB TOOLS, SAFETY INFORMATION, AND OTHER RESOURCES "AS IS" AND WITH ALL FAULTS, AND DISCLAIMS ALL WARRANTIES, EXPRESS AND IMPLIED, INCLUDING WITHOUT LIMITATION ANY IMPLIED WARRANTIES OF MERCHANTABILITY, FITNESS FOR A PARTICULAR PURPOSE OR NON-INFRINGEMENT OF THIRD PARTY INTELLECTUAL PROPERTY RIGHTS.

These resources are intended for skilled developers designing with TI products. You are solely responsible for (1) selecting the appropriate TI products for your application, (2) designing, validating and testing your application, and (3) ensuring your application meets applicable standards, and any other safety, security, regulatory or other requirements.

These resources are subject to change without notice. TI grants you permission to use these resources only for development of an application that uses the TI products described in the resource. Other reproduction and display of these resources is prohibited. No license is granted to any other TI intellectual property right or to any third party intellectual property right. TI disclaims responsibility for, and you will fully indemnify TI and its representatives against, any claims, damages, costs, losses, and liabilities arising out of your use of these resources.

TI's products are provided subject to [TI's Terms of Sale](#) or other applicable terms available either on [ti.com](https://www.ti.com) or provided in conjunction with such TI products. TI's provision of these resources does not expand or otherwise alter TI's applicable warranties or warranty disclaimers for TI products.

TI objects to and rejects any additional or different terms you may have proposed.

Mailing Address: Texas Instruments, Post Office Box 655303, Dallas, Texas 75265
Copyright © 2024, Texas Instruments Incorporated