

Single-Ended Input to Differential Output Circuit Using a Fully-Differential Amplifier



Sean Cashin

Design Goals

Input	Output	Supply	
Single-Ended	Differential	V_{cc}	V_{ee}
0 V to 1 V	16 Vpp	10 V	0 V

Output Common-Mode	3 dB Bandwidth	AC Gain (Gac)
5 V	3 MHz	16 V/V

Design Description

This design uses a fully-differential amplifier (FDA) as a single-ended input to differential output amplifier.

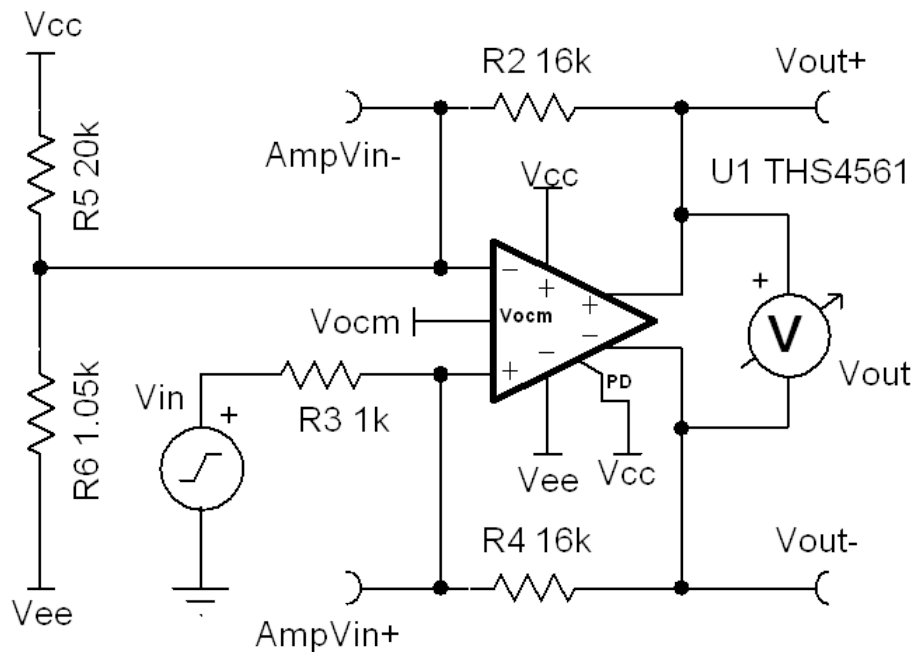

Design Notes

1. The ratio R_4/R_3 , equal to $R_2/(R_5||R_6)$, sets the gain of the amplifier.
2. The main difference between a single-ended input and a differential input is that the available input swing is only half. This is because one of the input voltages is fixed at a reference.
3. It is recommended to set this reference to mid-input signal range, rather than the min-input, to induce polarity reversal in the measured differential input. This preserves the ability of the outputs to crossover, which provides the doubling of output swing possible with an FDA.
4. The impedance of the reference voltage must be equal to the signal input resistor. This can be done by creating a resistor divider with a Thevni equivalent of the correct reference voltage and impedance.

Design Steps

- Find the resistor divider with that produces a 0.5V, 1-k Ω reference from $V_s = 10V$.

$$\frac{R_6}{R_5 + R_6} F = \frac{0.5V}{10V} \quad \frac{R_5 \cdot R_6}{R_5 + R_6} = E = 1k\Omega$$

$$R_6 = FR_5 + FR_6$$

$$R_6(1-F) = FR_5$$

$$R_5 = \frac{R_6(1-F)}{F}$$

$$\frac{R_6(1-F)/F \cdot R_6}{R_6(1-F)/F + R_6} = E$$

$$\frac{R_6^2 \cdot (1-F)/F}{(R_6/F - R_6) + R_6} = E$$

$$\frac{R_6^2 \cdot (1-F)/F}{R_6/F} = E$$

$$R_6 \cdot (1-F) = E$$

$$R_6 = \frac{E}{1-F} = \frac{1k\Omega}{1-0.05} = 1.05k\Omega$$

$$R_5 = \frac{1.05k\Omega(1-0.05)}{0.05} = 20k\Omega$$

- Verify that the minimum input of 0 V and the maximum input of 1 V result in an output within the 9.4 V range available for $V_{ocm} = 5 V$.

Since the resistor divider acts like a 0.5 V reference, the measured differential input for a 0 V V_{IN} is:

$$V_{IN} = 0V - 0.5V = -0.5V$$

- The output is:

$$-0.5V \cdot \frac{16V}{V} = -8V > -9.8V$$

- Likewise, for a 1 V input:

$$V_{IN} = 1V - 0.5V = 0.5V$$

$$0.5V \cdot \frac{16V}{V} = 8V < 9.8V$$

Note

With a reference voltage of 0 V, a 1 V input results in an output voltage greater than the maximum output range of the amplifier.

Design Simulations

AC Simulation Results

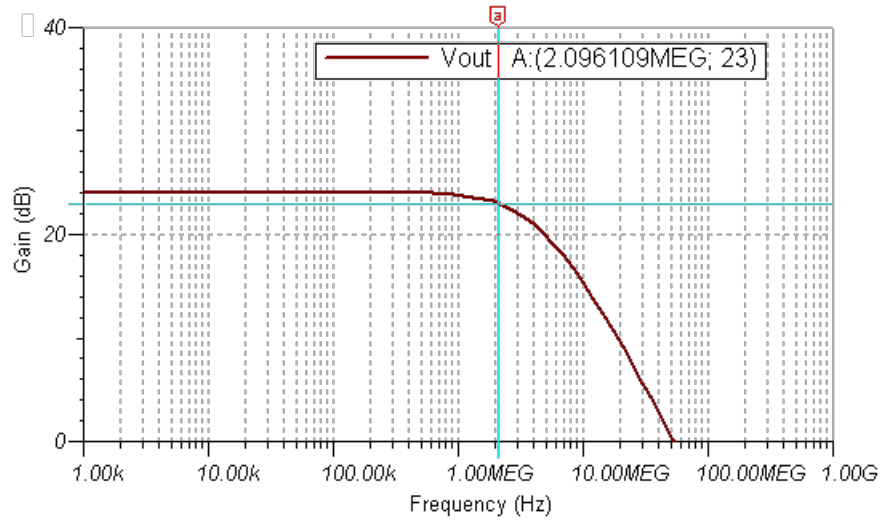

Transient Simulation Results

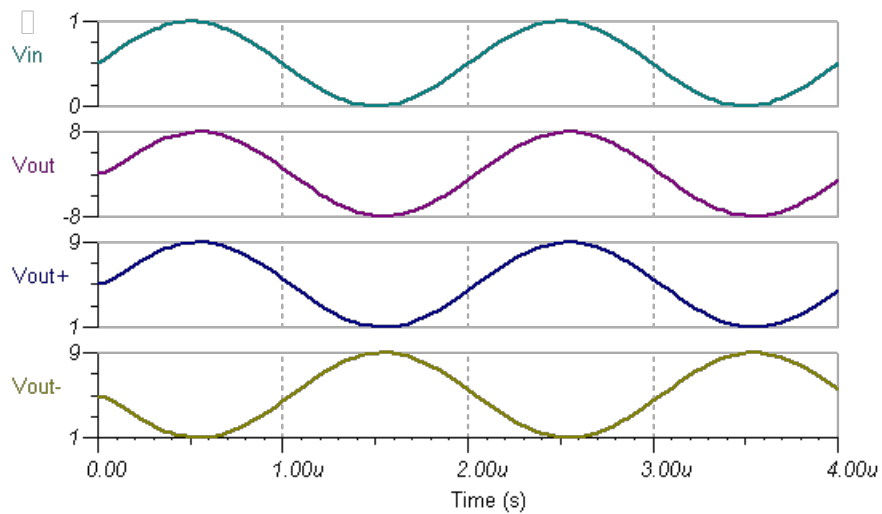

Design References

See [Analog Engineer's Circuit Cookbooks](#) for TI's comprehensive circuit library.

See the TI Precision Labs video – [Op Amps: Fully Differential Amplifiers – Designing a Front-End Circuit for Driving a Differential Input ADC](#), for more information.

Design Featured Op Amp

THS4561	
V_{SS}	3 V to 13.5 V
V_{inCM}	$V_{ee}-0.1$ V to $V_{cc}-1.1$ V
V_{out}	$V_{ee}+0.2$ V to $V_{cc}-0.2$
V_{os}	TBD
I_q	TBD
I_b	TBD
UGBW	70 MHz
SR	4.4 V/ μ s
#Channels	1
THS4561	

Design Alternate Op Amp

THS4131	
V_{SS}	5 V to 33 V
V_{inCM}	$V_{ee}+1.3$ V to $V_{cc}-0.1$ V
V_{out}	Varies
V_{os}	2 mV
I_q	14 mA
I_b	2 μ A
UGBW	80 MHz
SR	52 V/ μ s
#Channels	1
THS4131	

IMPORTANT NOTICE AND DISCLAIMER

TI PROVIDES TECHNICAL AND RELIABILITY DATA (INCLUDING DATA SHEETS), DESIGN RESOURCES (INCLUDING REFERENCE DESIGNS), APPLICATION OR OTHER DESIGN ADVICE, WEB TOOLS, SAFETY INFORMATION, AND OTHER RESOURCES "AS IS" AND WITH ALL FAULTS, AND DISCLAIMS ALL WARRANTIES, EXPRESS AND IMPLIED, INCLUDING WITHOUT LIMITATION ANY IMPLIED WARRANTIES OF MERCHANTABILITY, FITNESS FOR A PARTICULAR PURPOSE OR NON-INFRINGEMENT OF THIRD PARTY INTELLECTUAL PROPERTY RIGHTS.

These resources are intended for skilled developers designing with TI products. You are solely responsible for (1) selecting the appropriate TI products for your application, (2) designing, validating and testing your application, and (3) ensuring your application meets applicable standards, and any other safety, security, regulatory or other requirements.

These resources are subject to change without notice. TI grants you permission to use these resources only for development of an application that uses the TI products described in the resource. Other reproduction and display of these resources is prohibited. No license is granted to any other TI intellectual property right or to any third party intellectual property right. TI disclaims responsibility for, and you will fully indemnify TI and its representatives against, any claims, damages, costs, losses, and liabilities arising out of your use of these resources.

TI's products are provided subject to [TI's Terms of Sale](#) or other applicable terms available either on [ti.com](https://www.ti.com) or provided in conjunction with such TI products. TI's provision of these resources does not expand or otherwise alter TI's applicable warranties or warranty disclaimers for TI products.

TI objects to and rejects any additional or different terms you may have proposed.

Mailing Address: Texas Instruments, Post Office Box 655303, Dallas, Texas 75265
Copyright © 2023, Texas Instruments Incorporated