

Low-Noise and Long-Range PIR Sensor Conditioner Circuit with MSP430™ Smart Analog Combo



James Evans

Design Goals

AC Gain	Filter Cut-Off Frequency		Supply	
	f_L	f_H	V_{CC}	V_{EE}
90dB	0.7Hz	10Hz	3.3V	0V

Design Description

Some MSP430™ microcontrollers (MCUs) contain configurable integrated signal chain elements such as op-amps, DACs, and programmable gain stages. These elements make up a peripheral called the Smart Analog Combo (SAC). For information on the different types of SACs and how to leverage configurable analog signal chain capabilities, visit [MSP430 MCUs Smart Analog Combo Training](#). To get started with your design, download the [Low-Noise Long-Range PIR Sensor Conditioner Circuit Design Files](#).

This design leverages two of the four integrated op-amp blocks (SACs) in the [MSP430FR2355](#) MCU. Two SAC_L3 peripherals are configured as cascaded op-amps in general-purpose mode to amplify and filter the signal from a passive infrared (PIR) sensor. The circuit includes multiple low-pass and high-pass filters to reduce noise at the output of the circuit to be able to detect motion at long distances and reduce false triggers. The output of the second-stage op-amp in this circuit can be internally or externally connected to other integrated peripherals in the [MSP430FR2355](#) MCU. For example, the analog-to-digital converter (ADC) window comparator can sample this output periodically (with no CPU intervention) and trigger an interrupt when the signal crosses a threshold, indicating motion or an alert.

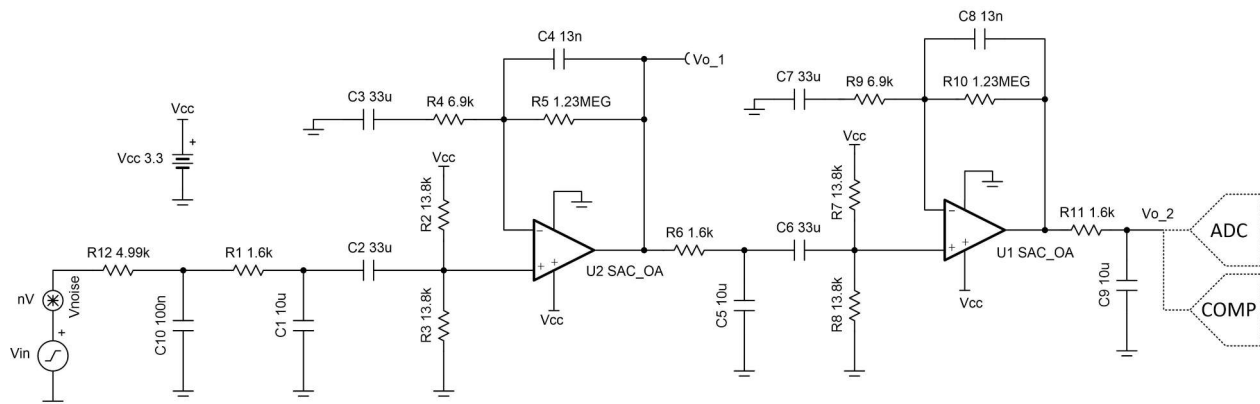

Design Notes

- The common-mode voltage and output-bias voltage are set using the resistor dividers between R_2 and R_3 (and R_7 and R_8).
- Two or more amplifier stages must be used to allow for sufficient loop gain.
- Additional low-pass and high-pass filters can be added to further reduce noise.
- Capacitors C_4 and C_8 filter noise by decreasing the bandwidth of the circuit and help stabilize the amplifiers.

- RC filters on the output of the amplifiers (for example, R_6 and C_5) are required to reduce the total integrated noise of the amplifier.
- The maximum gain of the circuit can be affected by the cut-off frequencies of the filters. Adjust the cut-off frequencies to achieve the desired gain.
- For this design, two SAC_L3 peripherals in the [MSP430FR2355](#) MCU are configured as cascaded op-amps in general-purpose mode.
- This design can also be implemented by using the transimpedance amplifier (TIA) and SAC_L1 peripheral in the [MSP430FR2311](#) MCU for the cascaded op-amps, but since the maximum input voltage of the TIA is limited to $V_{CC}/2$, limit the common-mode voltage and gain accordingly.
- The [Low-Noise Long-Range PIR Sensor Conditioner Circuit Design Files](#) include a code example demonstrating how to properly configure the SAC_L3 and ADC window comparator peripherals in the [MSP430FR2355](#) MCU.

Design Steps

1. Choose large-valued capacitors C_1 , C_5 , and C_9 for the low-pass filters. Select these capacitors first because large-valued capacitors have limited standard values to select from compared to standard resistor values.

$$C_1 = C_5 = C_9 = 10\mu\text{F}$$

2. Calculate resistor values for R_1 , R_6 , and R_{11} to form the low-pass filters.

$$R_1 = R_6 = R_{11} = \frac{1}{2\pi \times f_H \times C_1} = \frac{1}{2\pi \times 10\text{Hz} \times 10\mu\text{F}} = 1.592\text{k}\Omega$$

$$\text{Choose } R_1 = R_6 = R_{11} = 1.6\text{k}\Omega \quad (\text{Standard value})$$

3. Select capacitor values for C_2 , C_3 , C_6 , and C_7 for the high-pass filters.

$$C_2 = C_3 = C_6 = C_7 = 33\mu\text{F}$$

4. Calculate the resistor values for R_4 and R_9 for the high-pass filters.

$$R_4 = R_9 = \frac{1}{2\pi \times f_L \times C_2} = \frac{1}{2\pi \times 0.7\text{Hz} \times 33\mu\text{F}} = 6.89\text{k}\Omega$$

$$\text{Choose } R_4 = R_9 = 6.9\text{k}\Omega \quad (\text{Standard value})$$

5. Set the common-mode voltage of the amplifier to mid-supply using a voltage divider. The equivalent resistance of the voltage divider should be equal to R_4 to properly set the corner frequency of the high-pass filter.

$$R_2 = R_3 = R_7 = R_8 = 2 \times R_4 = 2 \times 6.9\text{k}\Omega = 13.8\text{k}\Omega$$

$$\text{Choose } R_2 = R_3 = R_7 = R_8 = 13.8\text{k}\Omega \quad (\text{Standard value})$$

6. Calculate the gain required by each gain stage to achieve the total gain requirement. Distribute the total gain target of the circuit evenly between both gain stages.

$$\text{Gain} = \frac{90\text{dB}}{2} = 45\text{dB} = 177.828\frac{\text{V}}{\text{V}}$$

7. Calculate R_5 to set the gain of the first stage.

$$R_5 = (\text{Gain} - 1) \times R_4 = \left(177.828\frac{\text{V}}{\text{V}} - 1\right) \times 6.9\text{k}\Omega = 1.22\text{M}\Omega$$

$$\text{Choose } R_5 = 1.23\text{M}\Omega \quad (\text{Standard value})$$

8. Calculate C_4 to set the low-pass filter cut-off frequency.

$$C_4 = \frac{1}{2\pi \times f_H \times R_5} = \frac{1}{2\pi \times 10\text{Hz} \times 1.23\text{M}\Omega} = 12.939\text{nF}$$

$$\text{Choose } C_4 = 13\text{nF} \quad (\text{Standard value})$$

9. Since the gain and cut-off frequency of the first gain stage is equal to the second gain stage, set all component values of both stages equal to each other.

$$R_1 = R_6 = 1.6\text{k}\Omega$$

$$R_7 = R_8 = 13.8\text{k}\Omega$$

$$R_9 = R_4 = 6.9\text{k}\Omega$$

$$R_{10} = R_5 = 1.23\text{M}\Omega$$

$$C_8 = C_4 = 13\text{nF}$$

10. Calculate R_{11} to set the cut-off frequency of the low-pass filter at the output of the circuit.

$$R_{11} = \frac{1}{2\pi \times f_H \times C_9} = \frac{1}{2\pi \times 10\text{Hz} \times 10\mu\text{F}} = 1.592\text{k}\Omega$$

Choose $R_{11} = 1.6\text{k}\Omega$ (Standard value)

Design Simulations

AC Simulation Results

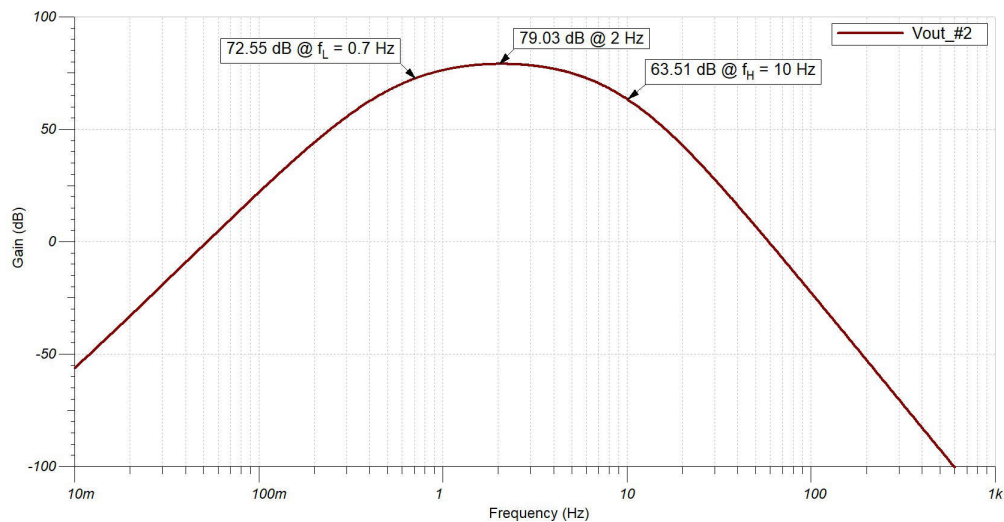

Noise Simulation Results

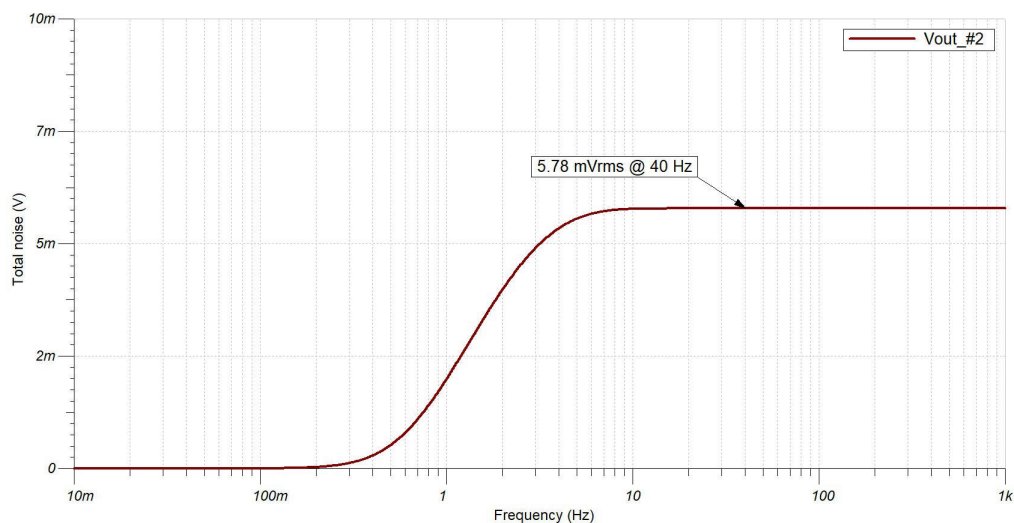

Target Applications

- [Motion detector](#)
- [Occupancy detection \(people tracking and people counting\)](#)
- [Building automation](#)
- [IP network camera](#)
- [Lighting sensor](#)
- [Thermostat](#)
- [Video doorbell](#)

References

1. Texas Instruments, [Low-Noise Long-Range PIR Sensor Conditioner Circuit](#), design files
2. Texas Instruments, [16MHz integrated analog microcontroller with 3.75-KB FRAM, Op Amp, TIA, comparator with DAC, 10-bit ADC](#), product page
3. Texas Instruments, [How to Use the Smart Analog Combo in MSP430™ MCUs](#), application report
4. Texas Instruments, [MSP430 MCUs Smart Analog Combo](#), training video





Design Featured Op Amp

MSP430FRxx Smart Analog Combo		
	MSP430FR2311 SAC_L1	MSP430FR2355 SAC_L3
V_{CC}	2.0V to 3.6V	
V_{CM}	-0.1V to V _{CC} + 0.1V	
V_{out}	Rail-to-rail	
V_{os}	±5mV	
A_{OL}	100dB	
I_q	350µA (high-speed mode)	
	120µA (low-power mode)	
I_b	50pA	
UGBW	4MHz (high-speed mode)	2.8MHz (high-speed mode)
	1.4MHz (low-power mode)	1MHz (low-power mode)
SR	3V/µs (high-speed mode)	
	1V/µs (low-power mode)	
Number of channels	1	4
	MSP430FR2311	MSP430FR2355

Design Alternate Op Amp

MSP430FR2311 Transimpedance Amplifier	
V_{CC}	2.0V to 3.6V
V_{CM}	-0.1V to $V_{CC}/2V$
V_{out}	Rail-to-rail
V_{os}	$\pm 5mV$
A_{OL}	100dB
I_q	350 μA (high-speed mode)
	120 μA (low-power mode)
I_b	5pA (TSSOP-16 with OA-dedicated pin input)
	50pA (TSSOP-20 and VQFN-16)
UGBW	5MHz (high-speed mode)
	1.8MHz (low-power mode)
SR	4V/ μs (high-speed mode)
	1V/ μs (low-power mode)
Number of channels	1
MSP430FR2311	

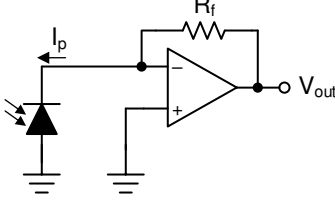
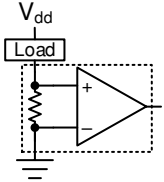
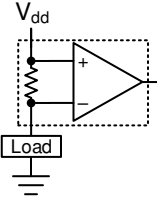
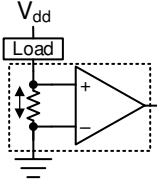
Related MSP430 Circuits

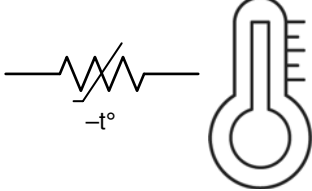
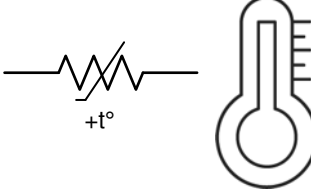
<p>Low-noise and long-range PIR sensor conditioner circuit</p> 	<p>Bridge amplifier circuit</p> 	<p>Transimpedance amplifier circuit</p> 
<p>Single-supply, low-side, unidirectional current-sensing circuit</p> 	<p>High-side current sensing with discrete difference amplifier circuit</p> 	<p>Low-side, bidirectional current-sensing circuit</p> 
<p>Half-wave rectifier circuit</p> 	<p>Temperature sensing with NTC thermistor circuit</p> 	<p>Temperature sensing with PTC thermistor circuit</p> 

Trademarks

MSP430™ is a trademark of Texas Instruments.
All trademarks are the property of their respective owners.

Revision History

NOTE: Page numbers for previous revisions may differ from page numbers in the current version.

Changes from Revision A (February 2020) to Revision B (October 2024) Page

- Updated the format for tables, figures, and cross-references throughout the document..... 1
-

Changes from Revision * (December 2019) to Revision A (February 2020) Page

- Added *Related MSP430 Circuits* section.....1
-

IMPORTANT NOTICE AND DISCLAIMER

TI PROVIDES TECHNICAL AND RELIABILITY DATA (INCLUDING DATA SHEETS), DESIGN RESOURCES (INCLUDING REFERENCE DESIGNS), APPLICATION OR OTHER DESIGN ADVICE, WEB TOOLS, SAFETY INFORMATION, AND OTHER RESOURCES "AS IS" AND WITH ALL FAULTS, AND DISCLAIMS ALL WARRANTIES, EXPRESS AND IMPLIED, INCLUDING WITHOUT LIMITATION ANY IMPLIED WARRANTIES OF MERCHANTABILITY, FITNESS FOR A PARTICULAR PURPOSE OR NON-INFRINGEMENT OF THIRD PARTY INTELLECTUAL PROPERTY RIGHTS.

These resources are intended for skilled developers designing with TI products. You are solely responsible for (1) selecting the appropriate TI products for your application, (2) designing, validating and testing your application, and (3) ensuring your application meets applicable standards, and any other safety, security, regulatory or other requirements.

These resources are subject to change without notice. TI grants you permission to use these resources only for development of an application that uses the TI products described in the resource. Other reproduction and display of these resources is prohibited. No license is granted to any other TI intellectual property right or to any third party intellectual property right. TI disclaims responsibility for, and you will fully indemnify TI and its representatives against, any claims, damages, costs, losses, and liabilities arising out of your use of these resources.

TI's products are provided subject to [TI's Terms of Sale](#) or other applicable terms available either on [ti.com](https://www.ti.com) or provided in conjunction with such TI products. TI's provision of these resources does not expand or otherwise alter TI's applicable warranties or warranty disclaimers for TI products.

TI objects to and rejects any additional or different terms you may have proposed.

Mailing Address: Texas Instruments, Post Office Box 655303, Dallas, Texas 75265
Copyright © 2024, Texas Instruments Incorporated