

EVM User's Guide: BQ25758EVM, BQ25758AEVM

BQ25758 and BQ25758A Evaluation Modules



Description

The BQ25758 and BQ25758A evaluation modules (EVM) are complete evaluation systems for the BQ25758 and BQ25758A ICs. The BQ25758EVM and the BQ25758AEVM have a max input and output of 55V and a max output current of 10A.

The BQ25758 and BQ25758A ICs are wide voltage, bidirectional switched-mode buck-boost controllers. These devices offer high-efficiency power conversion over a wide voltage range with output CC-CV control. These ICs have a wide input range of 4.2V to 60V and a wide output range of up to 60V.

Get Started

1. Order the EVM on ti.com
2. Order the [EV2400](https://ti.com) to communicate with the EVM
3. Download the BQ25758 BQZ file
4. Download the BQ25758 EVM design files on ti.com

Features

- Wide input voltage operating range: 4.2V to 55V
- Wide output operating range: up to 55V
- Synchronous buck-boost DC/DC controller with NFET drivers
 - Adjustable switching frequency from 200kHz to 600kHz
 - Optional synchronization to external clock
 - Optional gate driver supply input for optimized efficiency
- I²C-controlled or resistor programmable options
- Power up from battery (reverse mode) output 4V to 55V
- High safety integration
 - Adjustable input overvoltage and undervoltage protection
 - Output overvoltage and overcurrent protection

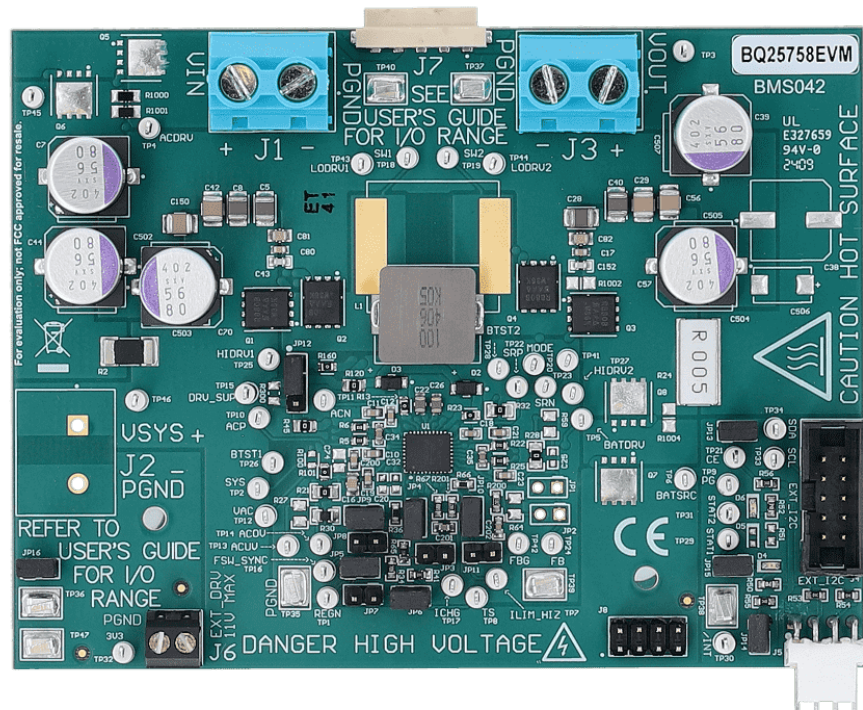

1 Evaluation Module Overview

1.1 Introduction

The BQ25758EVM and BQ25758AEVM can be evaluated for the full 240W range of USB Extended Power Range (EPR) in forward and reverse power direction. Typical applications include USB-PD extended power range applications, docking stations, monitors, and Portable Power Supplies.

This EVM does not include the EV2400 or USB2ANY interface device and does not provide any electrical isolation for the digital interfaces. EV2400 or USB2ANY must be ordered separately to evaluate the BQ25758EVM or BQ25758AEVM and electrical safety considerations must be considered when interfacing between the PC and the EVM board. When interfacing the EVM to the PC through the digital interfaces, digital isolators with isolation boundary is recommended.

The BQ25758EVM and BQ25758AEVM have smaller clearance and creepage than normally used on high voltage boards as well as not having an isolation boundary. If you apply high voltage to these boards, all terminals must be considered high voltage and hazardous live. Electric shock is possible when connecting the board to live wire. The boards must be handled with care by a professional. For safety, use of isolated test equipment with various protection features (such as overvoltage and overcurrent) is recommended.

1.2 Kit Contents

The BQ25758EVM kit includes:

- 1 BQ25758 EVM

The BQ25758AEVM kit includes:

- 1 BQ25758A EVM

1.3 Device Information

The BQ25758 and BQ25758A evaluation modules (EVMs) are an evaluation system for the BQ25758 and BQ25758A ICs. These ICs are buck-boost controllers with a wide input range of 4.2V to 60V, a wide output voltage range of up to 60V, and bi-directional capabilities.

The device offers high-efficiency DC/DC conversion over a wide voltage range. The device integrates all the loop compensation for the buck-boost converter, thereby providing a high density method with ease of use.

Besides the I²C host-controlled mode, the device also supports programmable hardware limits. Input current and output current regulation targets can be set with single resistor on the IIN, and IOOUT pins, respectively.

1.4 General Texas Instruments High Voltage Evaluation (TI HV EMV) User Safety Guidelines



Always follow TI's set-up and application instructions, including use of all interface components within their recommended electrical rated voltage and power limits. Always use electrical safety precautions to help verify your personal safety and those working around you. Contact TI's Product Information Center <http://ti.com/customer-support> for further information.

Save all warnings and instructions for future reference.

WARNING
Failure to follow warnings and instructions can result in personal injury, property damage or death due to electrical shock and burn hazards.

The term TI HV EVM refers to an electronic device typically provided as an open framed, unenclosed printed circuit board assembly. It is *intended strictly for use in development laboratory environments, solely for qualified professional users having training, expertise and knowledge of electrical safety risks in development and application of high voltage electrical circuits. Any other use and/or application are strictly prohibited by Texas Instruments.* If you are not suitably qualified, then you need to immediately stop from further use of the HV EVM.

1. Work Area Safety:

- a. Keep work area clean and orderly.
- b. Qualified observers must be present anytime circuits are energized.
- c. Effective barriers and signage must be present in the area where the TI HV EVM and the interface electronics are energized, indicating operation of accessible high voltages can be present, for the purpose of protecting inadvertent access.
- d. All interface circuits, power supplies, evaluation modules, instruments, meters, scopes, and other related apparatus used in a development environment exceeding 50Vrms/75VDC must be electrically located within a protected Emergency Power Off EPO protected power strip.
- e. Use stable and non-conductive work surface.
- f. Use adequately insulated clamps and wires to attach measurement probes and instruments. No freehand testing whenever possible.

2. Electrical Safety:

- a. As a precautionary measure, a good engineering practice to assume is that the entire EVM can have fully accessible and active high voltages.
- b. De-energize the TI HV EVM and all the inputs, outputs and electrical loads before performing any electrical or other diagnostic measurements. Revalidate that TI HV EVM power has been safely de-energized.
- c. With the EVM confirmed de-energized, proceed with required electrical circuit configurations, wiring, measurement equipment hook-ups and other application needs, while still assuming the EVM circuit and measuring instruments are electrically live.
- d. Once EVM readiness is complete, energize the EVM as intended.

WARNING
While the EVM is energized, never touch the EVM or the electrical circuits, as the electrical circuits and EVM can be at high voltages capable of causing electrical shock hazard.

3. Personal Safety

- a. Wear personal protective equipment e.g. latex gloves or safety glasses with side shields or protect EVM in an adequate lucent plastic box with interlocks from accidental touch.

Limitation for safe use:

EVMs are not to be used as all or part of a production unit.

1.4.1 General Safety Information

The following warnings and cautions are noted for the safety of anyone using or working close to the BQ25758EVM or BQ25758AEVM. Observe all safety precautions.



Warning. Caution

The BQ25758EVM and BQ25758AEVM circuit modules can become hot during operation due to the dissipation of heat. Avoid contact with the board. Follow all applicable safety procedures applicable to your laboratory.

CAUTION

Hot surface. Contact can cause burns. Do not touch!



Warning

The BQ25758EVM and BQ25758AEVM have smaller clearance and creepage than normally used on high voltage boards as well as not having an isolation boundary. If the user applies high voltage to this board, then all terminals are considered high voltage and hazardous live. Electric shock is possible when connecting the board to live wire. The board needs to be handled with care by a professional. For safety, use of isolated test equipment with various protection features (such as overvoltage and overcurrent) is recommended.



Warning

High voltages that can cause injury exist on this evaluation module (EVM). Please verify all safety procedures are followed when working on this EVM. Never leave a powered EVM unattended.



Warning

High voltage can be present on board capacitors after power down. Properly check and discharge all on-board energy reservoir after EVM power down.



Caution

Do not leave EVM powered when unattended.

CAUTION

The communication interfaces are not isolated on the EVM. The use of digital isolators is recommended. Verify all high voltage safety precautions are observed during testing.

CAUTION

Connections for rated current must be made at the terminal block. Test points are not rated for the board current.

CAUTION

The circuit module can be damaged by over temperature. To avoid damage, monitor the temperature during evaluation and provide cooling, as needed, for your system environment. Do not operate beyond the current and voltage limits in the [Section 2.3](#).

CAUTION

Test equipment can be damaged by application of external voltages. Check your equipment requirements and use blocking diodes or other isolation techniques, as needed, to prevent damage to your equipment.

CAUTION

The circuit module has signal traces, components, and component leads on the bottom of the board. This can result in exposed voltages, hot surfaces or sharp edges. Do not reach under the board during operation.

CAUTION

The default settings of the BQ25758 and BQ25758A are possibly not designed for the user's application. Verify the EVM settings are set appropriately for test setup before device power up. Set all protections appropriately and limit current for safe operation.

CAUTION

The board has no fuse installed and relies on the external voltage source current limit to verify circuit protection.

2 Hardware

2.1 Board Parameters

Table 2-1. Default Board Setup for the BQ25758EVM and BQ25758AEVM

	Description	Value	Unit
ACUV	Input undervoltage	4.2	V
ACOV	Input overvoltage	55	V
IIN	Input current of the EVM	8	A
IOUT	Output current of the EVM	10	A
FSW_SYNC	Switching frequency of the power stage	450	kHz
VOUT	Default Output Voltage	5	V
IAC Sense Resistor	Input current sense resistor	5	mΩ

Table 2-2. PCB and Mechanical Parameters for the BQ25758EVM and the BQ25758AEVM

	Value	Unit
Board size (X dimension, or length)	112	mm
Board size (Y dimension, or width)	84	mm
IC + power stage max height	5	mm
Total copper layers	6	layer
Copper weight per layer	2	oz
Total board thickness	62	mil

2.2 IO and Jumper Descriptions

Table 2-3. Connector/Port Description

Jack	Description
J1-VIN	Input: positive terminal
J1-PGND	Input: negative terminal (ground terminal)
J3-VOUT	Connected to load output
J3-PGND	Ground
J4-EXT_I2C	Communication port for the USB2ANY
J5-I2C	Communication port for the EV2400
J6-EXT_DRV	Connection for external gate drive
J7-Power Connector	Connection for VAC and BAT
J8-Communication Port	Connection for EXT_DRV, /INT, I2C, /PG, and 3.3V

Table 2-4. Jumper Description

Jumper	Description	Factory Default
JP3	Use JP3 to connect external IOOUT resistor. JP3 can be shorted to PGND to disable hardware output current limiting.	Not installed
JP4	Shunt JP4 to use default IOOUT resistor. By closing JP4, the default IOOUT current is set to 10A.	Installed
JP5	Shunt JP5 to bias TS.	Installed
JP6	With JP5 shunted (REGN connected for voltage divider). Shunt JP6 to set TS status to normal.	Installed
JP7	With JP5 shunted (REGN connected for voltage divider). Use JP7 to connect external resistor to change TS status.	Not installed
JP8	Use JP8 to connect external FSW_SYNC resistor.	Not installed
JP9	Shunt JP9 to use default FSW_SYNC resistor. By closing JP9, the default switching frequency is set to 250kHz.	Installed
JP10	Shunt JP10 to use default IIN resistor. By closing JP10, the maximum input current is set to 8A.	Installed
JP11	Use JP11 to connect external IIN resistor. JP11 can be shorted to PGND to disable hardware input current limiting.	Not installed
JP12	Use JP12 to select the gate driver source. Shunt pin1 to pin2 to use IC internal LDO REGN output. Shunt pin2 to pin3 to use external gate drive supply. Maximum external gate drive supply can be up to 11V.	Pin1 and pin2 shunted
JP13	Shunt JP13 to enable controller in forward mode. Open JP13 to disable controller. The /CE pin can also be used as a general purpose indicator.	Installed
JP14	Shunt JP14 to connect /INT to a pullup rail.	Installed
JP15	Shunt JP15 to connect STAT1 to a pullup rail. The STAT1 pin can also be used as a general purpose indicator.	Installed
JP16	Shunt JP16 to generate on board 3.3V pullup rail.	Installed

2.3 Recommended Operating Conditions

Table 2-5. Recommended Operating Conditions for BQ25758EVM and BQ25758AEVM

	Description	MIN	TYP	MAX	UNIT
VIN (J1)	Input voltage to the EVM	4.2		55 ⁽¹⁾	V
VOOUT (J3)	Output voltage of the EVM	3.3		55 ⁽¹⁾	V
IIN (J1)	Input current of the EVM			10 ⁽³⁾ (4)	A
IOOUT (J3)	Output current of the EVM			10 ⁽³⁾	A
Regulator output power	Output power of the EVM			400 ⁽³⁾	W
EXT_DRV (J6)	Voltage applied to DRV_SUP pin of the regulator	4		11	V
EVM operating ambient temperature (T _A)			25 ⁽²⁾		°C

- (1) Due to the high di/dt and dv/dt electrical flow associated with switch-mode power supplies, nodes on the EVM can have high spike above input voltage (in buck mode) or output voltage (in boost mode) level. Switch node voltage can swing up to "input or output + inductive spike" level. High side gate drives can swing up to "switch node voltage + 11V (DRV_SUP supply voltage dependent) + gate drive inductive spike" level. Safety precautions must be observed at all times.
- (2) Connectors, bump-ons, jumpers on the EVM are not a good choice for evaluation under temperature greatly deviated from room temperature of 25°C. Please refer to BOM for temperature rating of board components.
- (3) Thermal monitoring (for example, using a thermal camera) is recommended if power stage output current > 5A or total output power > 100W.
- (4) Default EVM input current limit is set to 8A through the IIN pin. The current limiting feature can be disabled by setting EN_IIN_PIN bit to '0', changing IIN pin resistor, or shorting IIN pin to PGND through JP11.

2.4 Equipment

The following list of equipment is recommended when testing with a constant voltage electronic load.

1. Power Supplies:

A power supply capable of supplying 40V at 8A is required. While this part can handle larger voltage and current, larger power levels are not necessary for this procedure.

2. Load #1:

An Eload: Kikusui PLZ164WA 0-150V, 0-33A, or equivalent

3. Meters:

Six Fluke 75 multimeters, (equivalent or better) or: Three equivalent voltage meters and three equivalent current meters.

4. Computer:

A computer with at least one USB port and a USB cable.

5. EV2400 Communication Kit:

Order here: <https://www.ti.com/tool/EV2400>

6. Software:

Download and properly install bqStudio from <https://www.ti.com/tool/BQSTUDIO>.

2.5 Equipment Setup

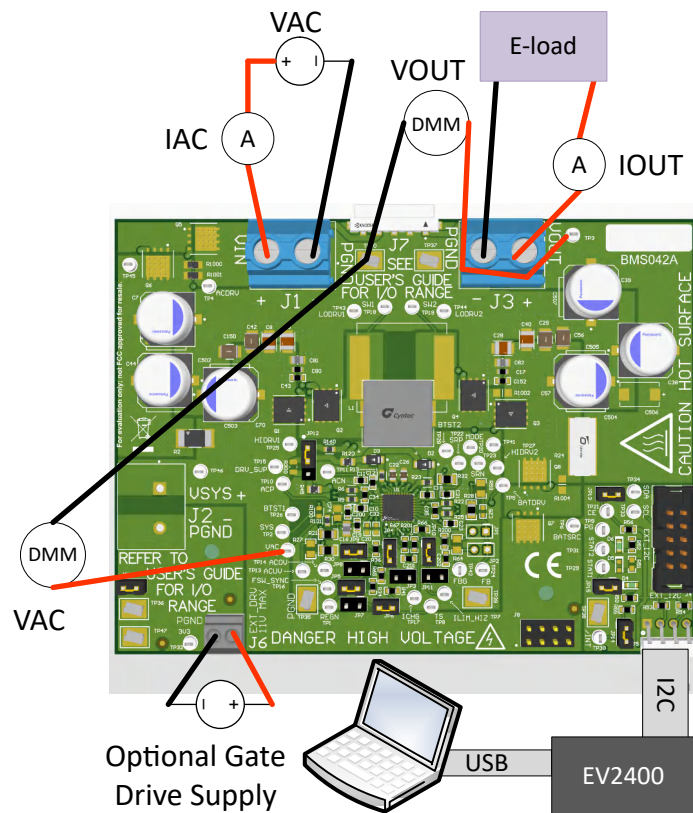

Use the following guidelines to set up the equipment:

1. Set power supply #1 for 20 VDC, 8A current limit and then turn off the supply.
2. Connect the output of power supply #1 in series with a current meter to J1 (VIN and PGND).
3. Connect a voltage meter across J1 (VIN) and J1 (PGND).
4. Connect load #1 in series with a current meter to J3 (VOUT and PGND).
5. Connect a voltage meter across J3 (VOUT and PGND).
6. Set electronic load to CC mode at 4A. Turn off load #1.
7. Connect J5 to the EV2400. Connect J5 to the I²C PORT 2 on the EV2400.
8. Make sure the jumpers are installed as indicated in IO and Jumper Descriptions.
9. Turn on the computer and power supply #1. Open the bqStudio software.
 - a. Select *Charger* and click the *Next* button.

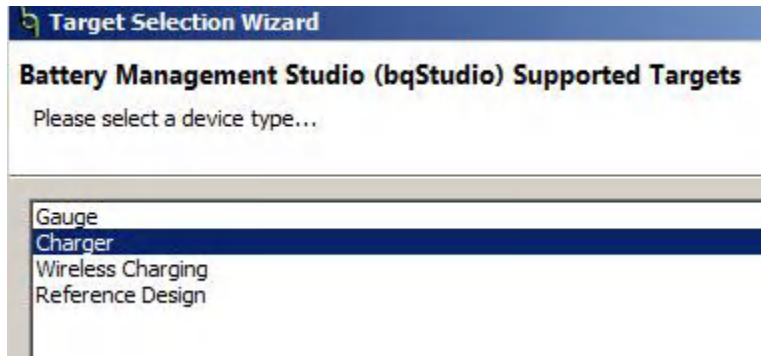

- b. Select *Charger_2_00_BQ25758.bqz* on the *Select a Target Page*.
- c. After selecting the target device, click *Field View* and then click the *Read Register* button.

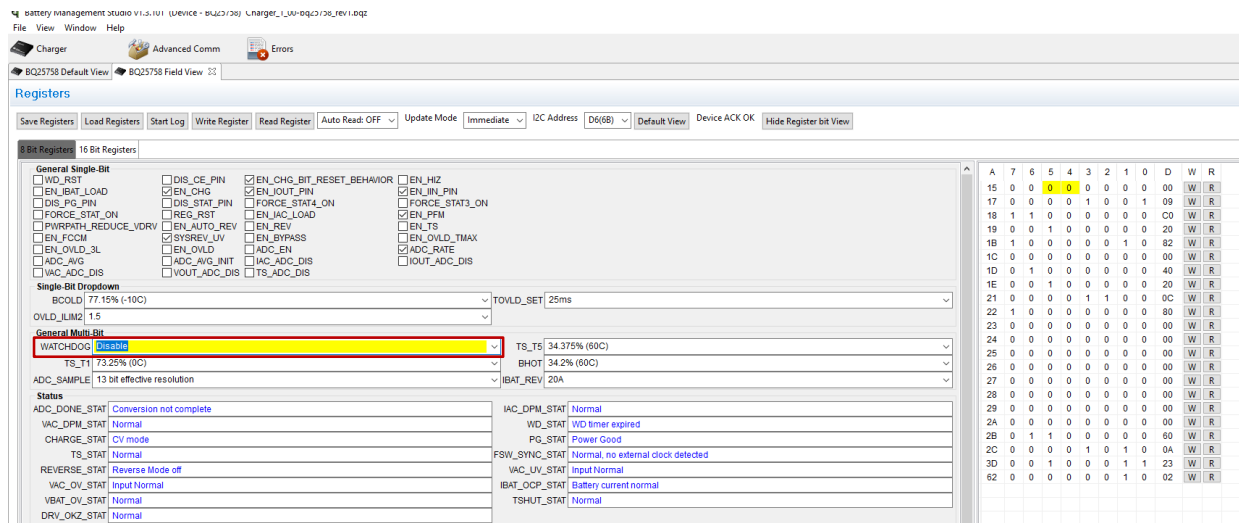

10. Set WATCHDOG to disabled.

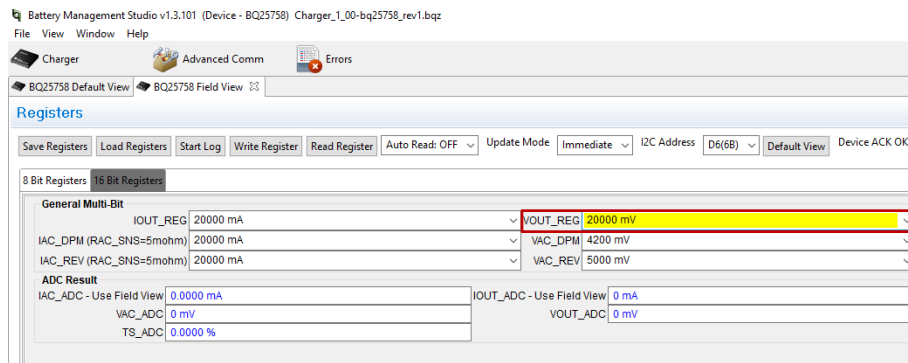

11. In *16 Bit Registers*, VOUT_REG default is 5000mV
12. **Buck Test** : Set VOUT_REG to 5V (5000mV) and then turn on load #1, measure
 - $V(J1(VAC)) = 20V \pm 0.5V$
 - $I(J1(IAC)) = 1A \pm 0.5A$
 - $V(J3(VOUT)) = 5V \pm 0.5V$
 - $I(J3(IOUT)) = 4A \pm 0.5A$
13. **Buck-Boost Test** : Set VOUT_REG to 20V (20000mV), measure
 - $V(J1(VAC)) = 20V \pm 0.5V$
 - $I(J1(IAC)) = 4A \pm 0.5A$
 - $V(J3(VOUT)) = 20V \pm 0.5V$
 - $I(J3(IOUT)) = 4A \pm 0.5A$
14. **Boost Test** : Set VOUT_REG to 36V (360000mV), measure
 - $V(J1(VAC)) = 20V \pm 0.5V$
 - $I(J1(IAC)) = 7.2A \pm 0.5A$
 - $V(J3(VOUT)) = 38V \pm 0.5V$
 - $I(J3(IOUT)) = 4A \pm 0.5A$

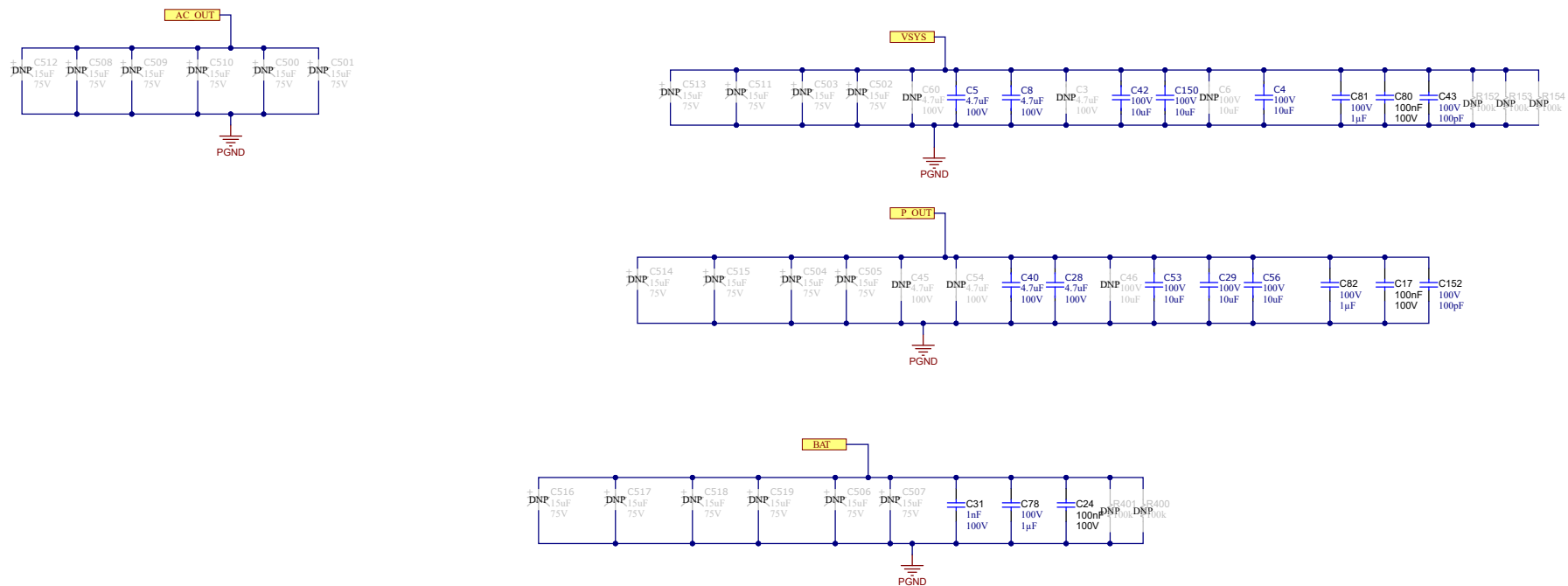

Figure 3-2. BQ25758 and BQ25758A EVM Schematic Page 2

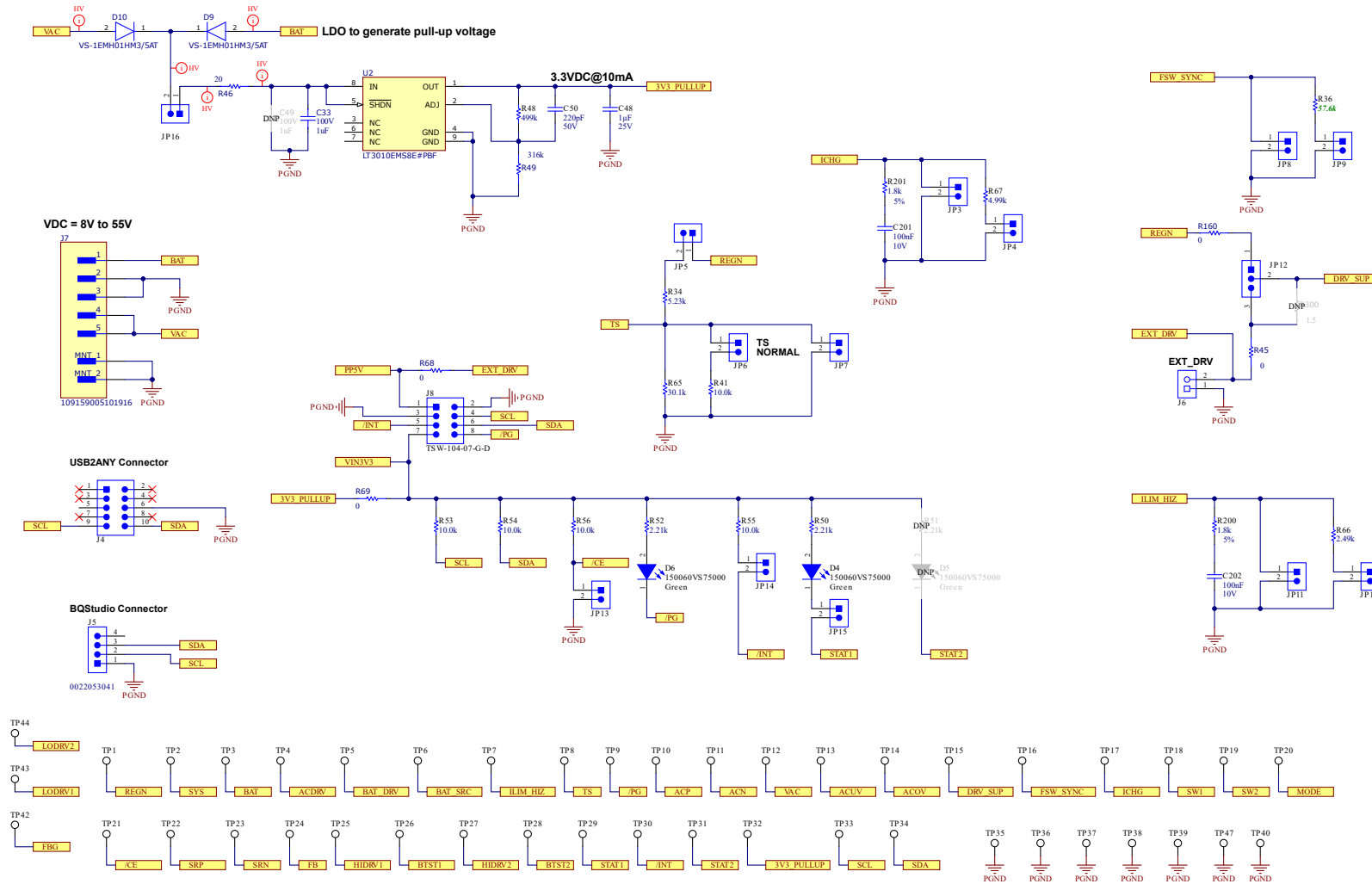
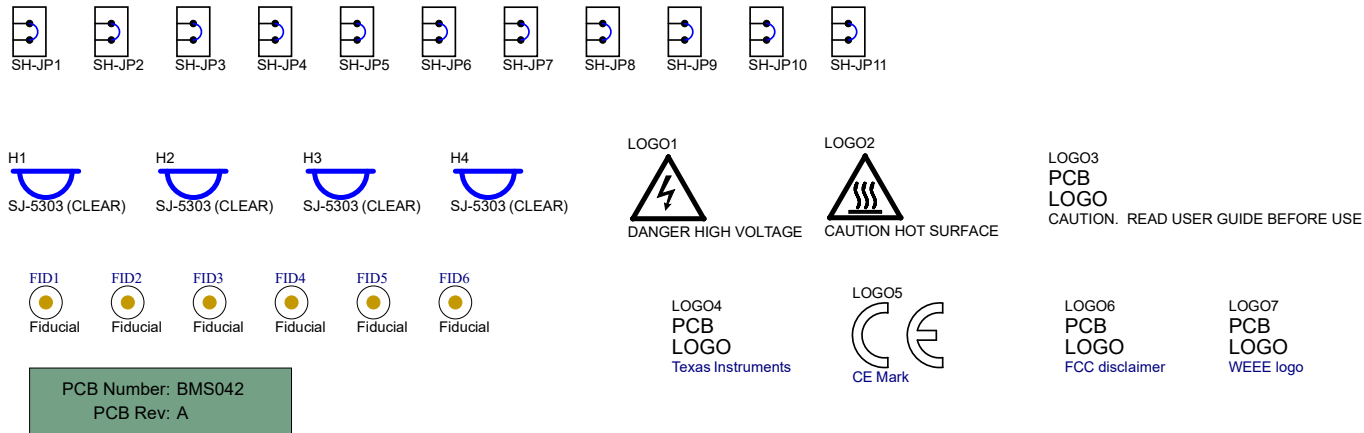

Figure 3-3. BQ25758 and BQ25758A EVM Schematic Page 3



ZZ1
Assembly Note

These assemblies are ESD sensitive, ESD precautions shall be observed.

ZZ2
Assembly Note

These assemblies must be clean and free from flux and all contaminants. Use of no clean flux is not acceptable.

ZZ3
Assembly Note

These assemblies must comply with workmanship standards IPC-A-610 Class 2, unless otherwise specified.

ZZ4
Assembly Note

Install label in silkscreened box after final wash. Text shall be 8 pt font. Text shall be per the Label Table in the PDF schematic.

ZZ5
Assembly Note

For BQ25750 variant, Install JP1, JP4, JP5, JP6, JP9, JP10, pin 1-2 of JP12, JP13, JP14, JP15, and JP16

ZZ6
Assembly Note

For BQ25758 variant, Install JP4, JP5, JP6, JP9, JP10, pin 1-2 of JP12, JP13, JP14, JP15, and JP16

ZZ7
Assembly Note

For BQ25756 variant, Install JP1, JP4, JP5, JP6, JP9, JP10, pin 1-2 of JP12, JP13, JP14, JP15, and JP16

Figure 3-4. BQ25758 and BQ25758A EVM Schematic Page

1. DNP means "Do Not Populate".

3.2 PCB Layout

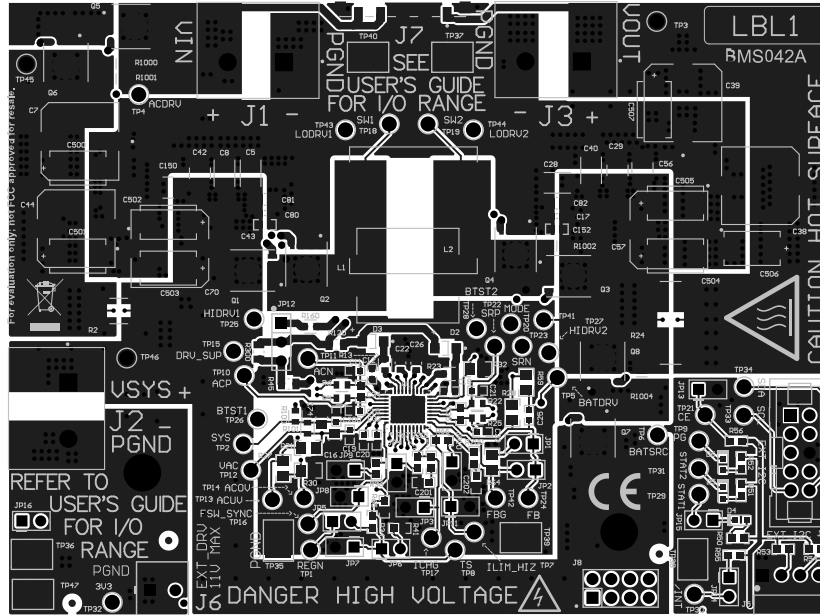

Figure 3-5. Top Layer and Overlay

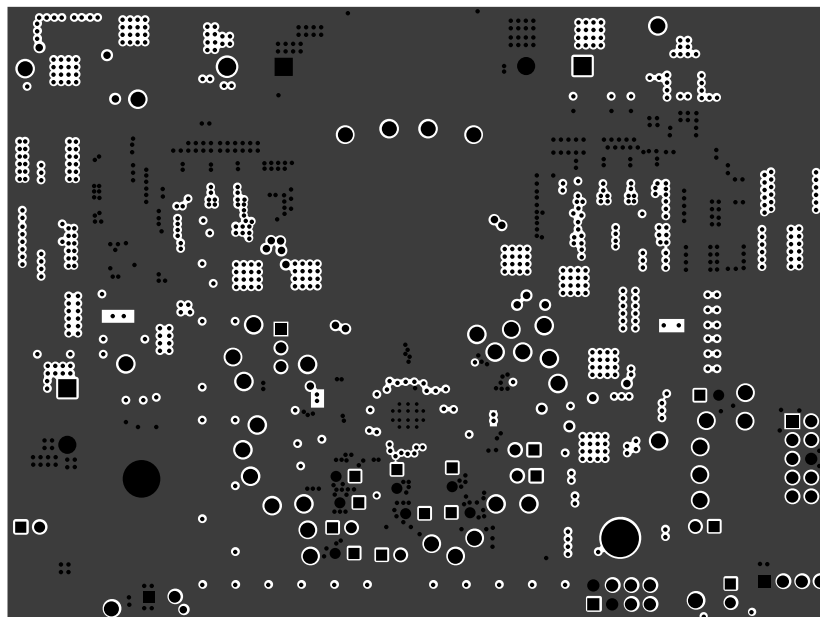

Figure 3-6. Layer 2 -GND

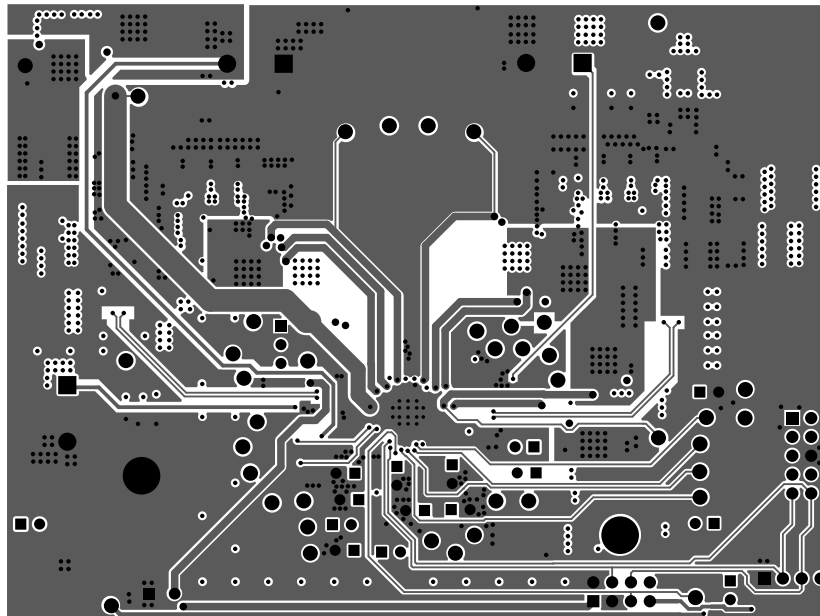

Figure 3-7. Signal Layer 1

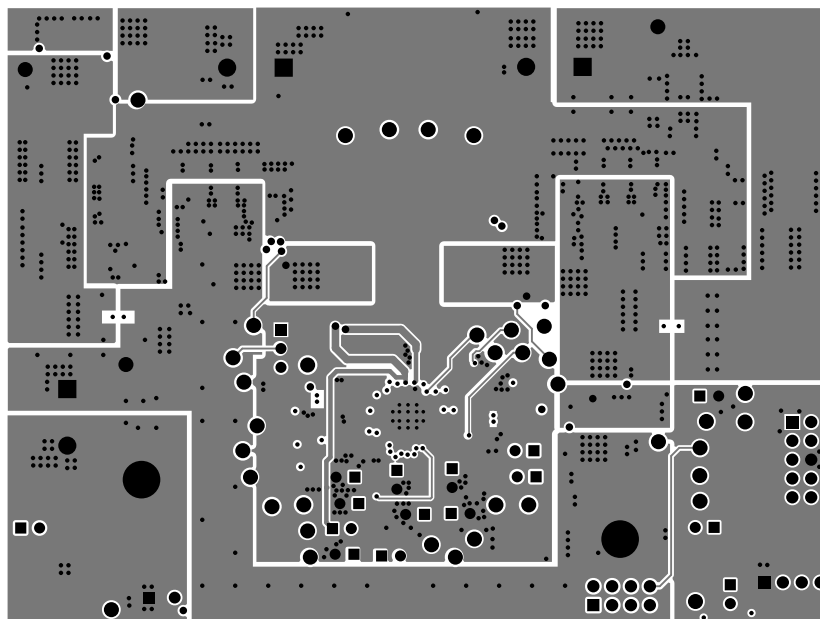

Figure 3-8. Signal Layer 2

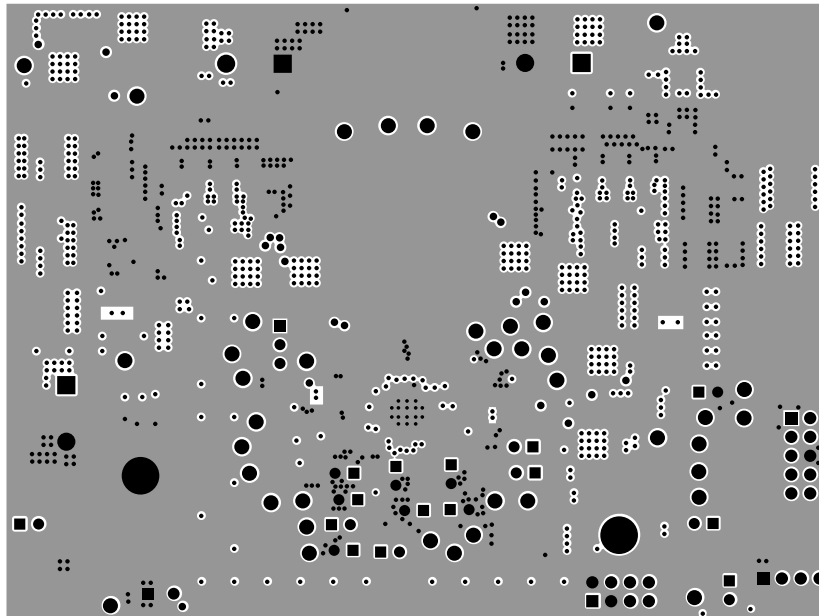

Figure 3-9. Layer 5 - GND

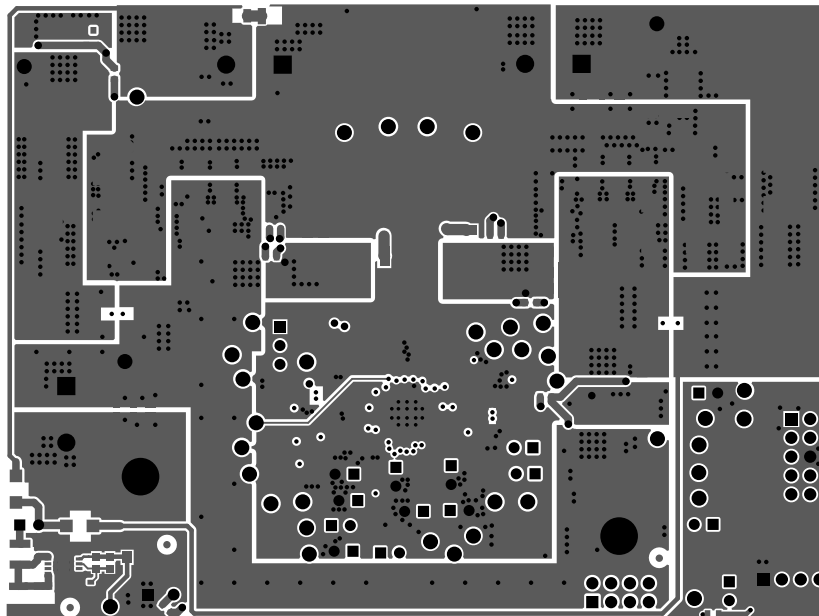

Figure 3-10. Bottom Layer

3.3 Bill of Materials

Table 3-1. Bill of Materials

Item Number	Designator	Quantity	Value	Part Number	Manufacturer	Description	Package Reference
1	C2, C5, C8, C28, C40	5	4.7 μ F	GCJ32DC72A475KE01L	Murata	4.7uF \pm 10% 100V Ceramic Capacitor X7S 1210 (3225 Metric)	1210
2	C4, C29, C42, C53, C56, C150	6	10 μ F	C3225X7R2A106K250AC	TDK	10 μ F \pm 10% 100V Ceramic Capacitor X7R 1210 (3225 Metric)	1210
3	C7, C38, C39, C44, C57, C70	5	56 μ F	80SXV56M	Panasonic	56 μ F 80V Aluminum - Polymer Capacitors Radial, Can - SMD 28mOhm 1000 Hrs @ 125°C	SMT_CAP_10MM3_10MM3
4	C10, C11, C17, C19, C21, C23, C24, C80, C200	9	0.1 μ F	HMK107B7104KAHT	Taiyo Yuden	CAP, CERM, 0.1 μ F, 100V, +/- 10%, X7R, AEC-Q200 Grade 1, 0603	603
5	C12, C18	2	0.1 μ F	06033C104KAT2A	AVX	CAP, CERM, 0.1uF, 25V, +/- 10%, X7R, 0603	603
6	C13	1		CGA6N3X7R2A225K230AE	TDK Corporation	Cap Ceramic 2.2uF 100V X7R 10% SMD 1210 FlexiTerm 125C Plastic T/R	1210
7	C16, C78, C81, C82	4	1 μ F	08051C105K4Z2A	AVX	CAP, CERM, 1 μ F, 100V, +/- 10%, X7R, AEC-Q200 Grade 1, 0805	805
8	C22, C26	2	4.7 μ F	CGA4J1X7R1E475K125AE	TDK Corporation	Cap Ceramic 4.7uF 25V X7R 10% Pad SMD 0805 +125°C Automotive T/R	805
9	C31	1	1000pF	CGA3E2X7R2A102K080AA	TDK	Multilayer Ceramic Capacitors MLCC - SMD/SMT CGA 0603 100V 1000pF X7R 10% AEC-Q200	603
10	C33	1	1 μ F	12101C105KAT2A	AVX	General Purpose Ceramic Capacitor, 1210, 1uF, 10%, X7R, 15%, 100V	1210
11	C34, C35	2	0.47 μ F	C0603C474K4RACTU	Kemet	CAP, CERM, 0.47uF, 16V, +/- 10%, X7R, 0603	603
12	C43, C152	2	100pF	CGA3E2C0G2A101J080AA	TDK	Multilayer Ceramic Capacitors MLCC - SMD/SMT CGA 0603 100V 100pF C0G 5% AEC-Q200	603
13	C48	1	1 μ F	C0805C105K3RACTU	Kemet	CAP, CERM, 1uF, 25V, +/- 10%, X7R, 0805	805
14	C50	1	220pF	C0603C221K5RACTU	Kemet	CAP, CERM, 220pF, 50V, +/- 10%, X7R, 0603	603
15	C201, C202	2	0.1 μ F	C0603C104K8RACTU	Kemet	CAP, CERM, 0.1uF, 10V, +/- 10%, X7R, 0603	603
16	D2, D3	2		V1FM10-M3/H	Vishay	Diode Schottky 1A Surface Mount DO-219AB (SMF)	DO-219AB
17	D4, D6	2	Green	150060VS75000	Würth Elektronik	LED, Green, SMD	LED_0603
18	D9, D10	2		VS-1EMH01HM3/5AT	Vishay	Diode Standard 100V 1A Surface Mount DO-214AC (SMA)	DO-214AC
19	FID1, FID2, FID3, FID4, FID5, FID6	6		N/A	N/A	Fiducial mark. There is nothing to buy or mount.	N/A

Table 3-1. Bill of Materials (continued)

Item Number	Designator	Quantity	Value	Part Number	Manufacturer	Description	Package Reference
20	H1, H2, H3, H4	4		SJ-5303 (CLEAR)	3M	Bumpon, Hemisphere, 0.44 X 0.20, Clear	Transparent Bumpon
21	J1, J3	2		TB005-762-02BE	CUI Devices		TERM_CONN
22	J4	1		N2510-6002-RB	3M	Header (shrouded), 100mil, 5x2, High-Temperature, Gold, TH	5x2 Shrouded header
23	J5	1		22053041	Molex	Header (friction lock), 100mil, 4x1, R/A, TH	4x1 R/A Header
24	J6	1		393570002	Molex	Terminal Block, 3.5mm, 2x1, Tin, TH	Terminal Block, 3.5mm, 2x1, TH
25	J7	1		1.09159E+14	KYOCERA AVX	Conn Board to Board HDR 5 POS 3mm Solder RA SMD T/R	CONN_SSL_PLUG5
26	J8	1		TSW-104-07-G-D	Samtec	Header, 100mil, 4x2, Gold, TH	4x2 Header
27	JP3, JP4, JP5, JP6, JP7, JP8, JP9, JP10, JP11, JP13, JP14, JP15, JP16	13		PEC02SAAN	Sullins Connector Solutions	Header, 100mil, 2x1, Tin, TH	Header, 2 PIN, 100mil, Tin
28	JP12	1		PEC03SAAN	Sullins Connector Solutions	Header, 100mil, 3x1, Tin, TH	Header, 3 PIN, 100mil, Tin
29	L2	1	10uH	CMLB135T-100MS	Cyntec	Power Choke Coil 10uH 20% 9A 22mOhm	SMT2_13MM45_12Mm6
30	LBL1	1		THT-14-423-10	Brady	Thermal Transfer Printable Labels, 0.650" W x 0.200" H - 10,000 per roll	PCB Label 0.650 x 0.200 inch
31	PCB1	1		BMS042	Any	Printed Circuit Board	
32	Q1, Q2, Q3, Q4	4		SIR880BDP-T1-RE3	Vishay	N-Channel 80V 18.6A (Ta), 70.6A (Tc) 5W (Ta), 71.4W (Tc) Surface Mount PowerPAK® SO-8	SO-8
33	R2	1	5m	WSL25125L000FEA	Vishay	Res Metal Strip 2512 0.005 Ohm 1% 1W 110ppm/C Molded SMD SMD Embossed Plastic T/R	2512
34	R3, R8, R13, R17, R20, R23, R68, R69, R101, R160	10	0	CRCW06030000Z0EA	Vishay	Thick Film Resistors - SMD 1/10watt ZEROohm Jumper	603
35	R5, R6, R22, R25	4	10	CRCW060310R0FKEB	Vishay	RES Thick Film, 10Ω, 1%, 0.1W, 100ppm/°C, 0603	603
36	R10	1	10	CRCW120610R0FKEAHP	Vishay Dale	RES Thick Film, 10Ω, 1%, 0.75W, 100ppm/°C, 1206	1206
37	R21, R32	2	0	CRCW08050000Z0EA	Vishay-Dale	RES, 0, 5%, 0.125 W, AEC-Q200 Grade 0, 0805	805
38	R24	1	5m	FCSL110R005FER	Ohmite	5 mOhms ±1% 5W Chip Resistor Wide 4320 (11050 Metric), 2043 Current Sense, Moisture Resistant Metal Foil	WIDE_4320

Table 3-1. Bill of Materials (continued)

Item Number	Designator	Quantity	Value	Part Number	Manufacturer	Description	Package Reference
39	R28	1	0	RC0805FR-070RL	Yageo America	Thick Film Resistors - SMD 0 Ohms 125mW 0805 1%	805
40	R30	1	29.4k	ERJ-6ENF2942V	Panasonic	RES, 29.4 k, 1%, 0.125W, AEC-Q200 Grade 0, 0805	805
41	R34	1	5.23k	RC0603FR-075K23L	Yageo	RES, 5.23 k, 1%, 0.1W, 0603	603
42	R36	1	57.6k	RC0603FR-0757K6L	Yageo	RES, 57.6 k, 1%, 0.1W, 0603	603
43	R41, R53, R54, R55, R56	5	10.0k	RC0603FR-0710KL	Yageo	RES, 10.0 k, 1%, 0.1W, 0603	603
44	R45, R120	2	0	CRCW08050000Z0EA	Vishay	Thick Film Resistors - SMD 1/8watt ZEROohm Jumper	805
45	R46	1	20	CRCW121020R0FKEAHP	Vishay Dale	Thick Film Resistors - SMD 3/4watt 20ohms 1% High Power AEC-Q200	1210
46	R48	1	499k	RC0603FR-07499KL	Yageo	RES, 499k, 1%, 0.1W, 0603	603
47	R49	1	316k	CR0603-FX-3163ELF	Bourns	Thick Film Chip Resistors 0603 316kΩ 0.1W 1% 100ppm/°C	603
48	R50, R52	2	2.21k	RC0603FR-072K21L	Yageo	RES, 2.21k, 1%, 0.1W, 0603	603
49	R65	1	30.1k	RC0603FR-0730K1L	Yageo	RES, 30.1k, 1%, 0.1W, 0603	603
50	R66	1	2.49k	RC0603FR-072K49L	Yageo	RES, 2.49k, 1%, 0.1W, 0603	603
51	R67	1	4.99k	CRCW06034K99FKEAC	Vishay-Dale	RES, 4.99k, 1%, 0.1W, 0603	603
52	R200, R201	2	1.8k	RC0603JR-071K8L	Yageo	RES, 1.8 k, 5%, 0.1 W, 0603	603
53	R1000, R1001	2	0	JR0805X35E	Ohmite	0 Ohms Jumper 0.245W Chip Resistor 0805 (2012 Metric) - Metal Element	805
54	SH-JP1, SH-JP2, SH-JP3, SH-JP4, SH-JP5, SH-JP6, SH-JP7, SH-JP8, SH-JP9, SH-JP10	10	1x2	SNT-100-BK-G	Samtec	Shunt, 100mil, Gold plated, Black	Shunt

Table 3-1. Bill of Materials (continued)

Item Number	Designator	Quantity	Value	Part Number	Manufacturer	Description	Package Reference
55	TP1, TP2, TP3, TP4, TP5, TP6, TP7, TP8, TP9, TP10, TP11, TP12, TP13, TP14, TP15, TP16, TP17, TP18, TP19, TP20, TP21, TP22, TP23, TP24, TP25, TP26, TP27, TP28, TP29, TP30, TP31, TP32, TP33, TP34, TP41, TP42, TP43, TP44, TP45, TP46	40		5002	Keystone	Test Point, Miniature, White, TH	White Miniature Testpoint
56	TP35, TP36, TP37, TP38, TP39, TP40, TP47	7		5016	Keystone	Test Point, Compact, SMT	Testpoint_Keystone_Compact
57	U1	1		BQ25758 or BQ25758A	Texas Instruments	I2C Controlled, 70V Buck-Boost Multi-Chemistry Battery Charge Controller	VQFN36
58	U2	1		LT3010EMS8E-PBF	Analog Devices	Linear Voltage Regulator IC Positive Adjustable 1 Output 50mA 8-MSOP-EP	MSOP8

4 Revision History

NOTE: Page numbers for previous revisions may differ from page numbers in the current version.

Changes from Revision * (March 2024) to Revision A (August 2024)	Page
• Updated document to include BQ25758AEVM.....	1

IMPORTANT NOTICE AND DISCLAIMER

TI PROVIDES TECHNICAL AND RELIABILITY DATA (INCLUDING DATA SHEETS), DESIGN RESOURCES (INCLUDING REFERENCE DESIGNS), APPLICATION OR OTHER DESIGN ADVICE, WEB TOOLS, SAFETY INFORMATION, AND OTHER RESOURCES "AS IS" AND WITH ALL FAULTS, AND DISCLAIMS ALL WARRANTIES, EXPRESS AND IMPLIED, INCLUDING WITHOUT LIMITATION ANY IMPLIED WARRANTIES OF MERCHANTABILITY, FITNESS FOR A PARTICULAR PURPOSE OR NON-INFRINGEMENT OF THIRD PARTY INTELLECTUAL PROPERTY RIGHTS.

These resources are intended for skilled developers designing with TI products. You are solely responsible for (1) selecting the appropriate TI products for your application, (2) designing, validating and testing your application, and (3) ensuring your application meets applicable standards, and any other safety, security, regulatory or other requirements.

These resources are subject to change without notice. TI grants you permission to use these resources only for development of an application that uses the TI products described in the resource. Other reproduction and display of these resources is prohibited. No license is granted to any other TI intellectual property right or to any third party intellectual property right. TI disclaims responsibility for, and you will fully indemnify TI and its representatives against, any claims, damages, costs, losses, and liabilities arising out of your use of these resources.

TI's products are provided subject to [TI's Terms of Sale](#) or other applicable terms available either on [ti.com](https://www.ti.com) or provided in conjunction with such TI products. TI's provision of these resources does not expand or otherwise alter TI's applicable warranties or warranty disclaimers for TI products.

TI objects to and rejects any additional or different terms you may have proposed.

Mailing Address: Texas Instruments, Post Office Box 655303, Dallas, Texas 75265
Copyright © 2024, Texas Instruments Incorporated