

Understanding the pen-interrupt ($\overline{\text{PENIRQ}}$) operation of touch-screen controllers

By Wendy Fang, Precision Analog Applications, High-Performance Analog, and Ing-Yih James Wang, Design Engineer, Precision Analog

Introduction

The TSC2003¹ and TSC2007² are both four-wire touch-screen controllers (TSCs) with an I²C interface. These two devices are completely hardware-compatible with respective TSSOP-16 packages; they are also software-compatible in many applications.³

The digital output, or hardware interrupt pin on a TSC2003 or TSC2007 device is called $\overline{\text{PENIRQ}}$. It provides rich information on the touch screen system and its various connections. For example, this pin indicates whether the TSC device works as it should, or if the TSC system analog interface is properly connected. Observing the $\overline{\text{PENIRQ}}$ pin is very useful for properly configuring the system in a given application as well as debugging the TSC device operation.

Many users may presume that the $\overline{\text{PENIRQ}}$ pin responds only to touch on the panel and may be surprised by several exceptional $\overline{\text{PENIRQ}}$ behaviors. For instance, the $\overline{\text{PENIRQ}}$ pin does not seem to work the same after the touch panel or the surrounding environment (such as temperature) changes. $\overline{\text{PENIRQ}}$ also goes high at times even though the user maintains pressure on the panel. These behaviors (as well as others) are often unexpected.

This article discusses these types of behaviors and describes how the $\overline{\text{PENIRQ}}$ pin may be expected to operate under a variety of conditions. It also explains the principles of the $\overline{\text{PENIRQ}}$ pin, and provides information about how and where to investigate $\overline{\text{PENIRQ}}$ behaviors.

Throughout this article, the abbreviation TSC200x refers to both the TSC2003 and the TSC2007, except where stated otherwise.

$\overline{\text{PENIRQ}}$ function

To understand the $\overline{\text{PENIRQ}}$ function, we must first start with the operation of the entire TSC200x touch screen system.

As Figure 1 shows, there are two interfaces in a TSC system: one is the analog interface (X+, X-, Y+, and Y-) between the TSC and the touch panel, and the other is the digital interface (SCL, SDA, and $\overline{\text{PENIRQ}}$) between the TSC and the host processor. The digital interface is at the center of the discussion in this article.

When there is no touch or pressure applied to the touch panel, the touch-screen system is in a wait and sleep state; the I²C bus lines (SCL and SDA) and the pen-detect interrupt ($\overline{\text{PENIRQ}}$) are all inactive or at logic high.

When pressure or a touch is applied to the system touch panel, the TSC200x detects the touch. Correspondingly, $\overline{\text{PENIRQ}}$ goes low or becomes active, and sends an interrupt request to the host. Upon receiving the $\overline{\text{PENIRQ}}$ signal, the host processor then sends the TSC a command through the I²C bus. In response to the command from the host, the TSC then powers on the corresponding touch-panel driver and starts the touch-data sampling/converting (or filtering). The data are then sent from the TSC to the host via the I²C interface. The system continues this cycle as long as the touch remains applied to the panel. Refer to the related sections in the product data sheets^{1, 2} for further details on the I²C digital interface.

When the pressure is released or the touch is removed, the $\overline{\text{PENIRQ}}$ returns high or becomes inactive. The entire touch screen system returns to the wait state again.

Figure 1. TSC200x touch-screen system

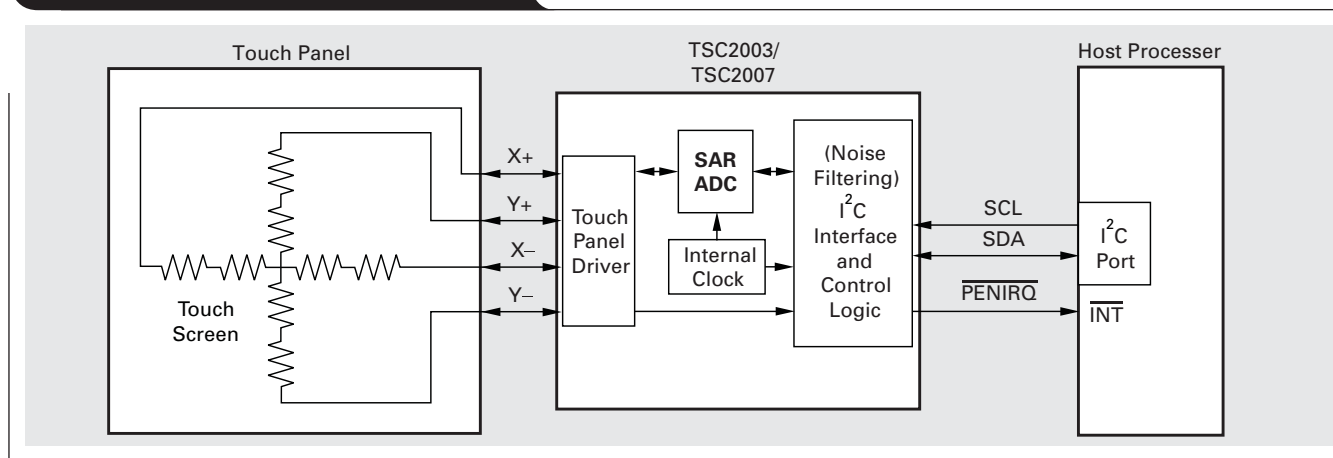

Figure 2. TSC200x $\overline{\text{PENIRQ}}$ behavior following touch-on or touch-off activity on panel

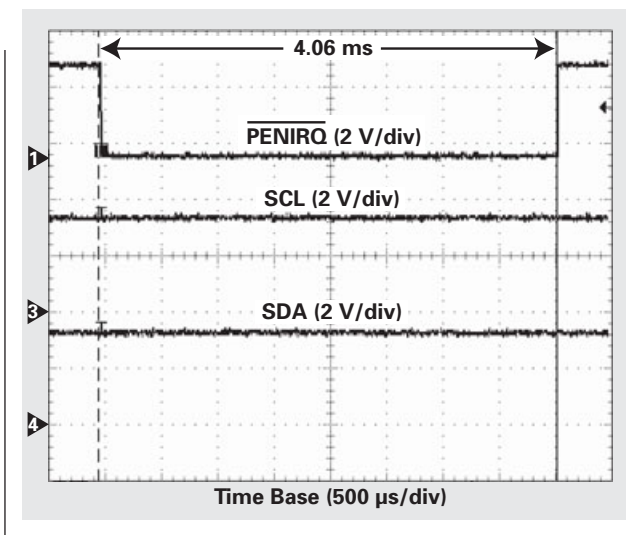
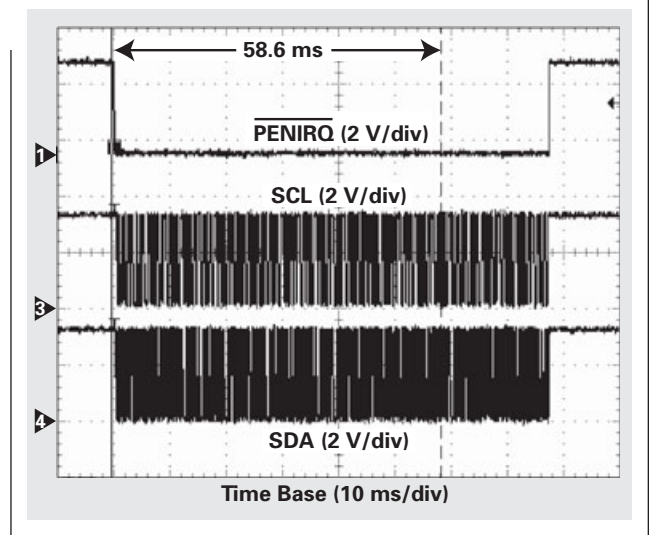

Figure 3. TSC200x $\overline{\text{PENIRQ}}$ behavior with full I²C interface



Clearly, the $\overline{\text{PENIRQ}}$ is usually the trigger that moves the TSC device to either a wait state (if $\overline{\text{PENIRQ}}$ is inactive) or an awake state (if $\overline{\text{PENIRQ}}$ is active). However, there are some cases where $\overline{\text{PENIRQ}}$ may not be used to trigger the touch system in some applications; these exceptions will not be discussed in this article.

The TSC200x $\overline{\text{PENIRQ}}$ reflects the touch-on and touch-off activity on the touch-screen panel, as shown in Figure 2 and Figure 3. Figure 2 illustrates the digital interface when the host software has not yet been loaded; Figure 3 is the digital behavior with a complete I²C interface.

$\overline{\text{PENIRQ}}$ working principle

The function of the TSC200x $\overline{\text{PENIRQ}}$, once it is enabled, can be simplified by the block diagram shown in Figure 4 with Q1 and Q4 ON; and Q2 and Q3 OFF.

When the touch panel is not pressed, the touch-panel X and Y layers are separated and the power from the TSC touch-panel driver cannot run to ground. Thus, there is no driving current in the analog interface, and the entire system is in a waiting (that is, sleep) mode. The voltage at point B in Figure 4 is equal to V_{DD} .

Figure 4. $\overline{\text{PENIRQ}}$ functional block diagram

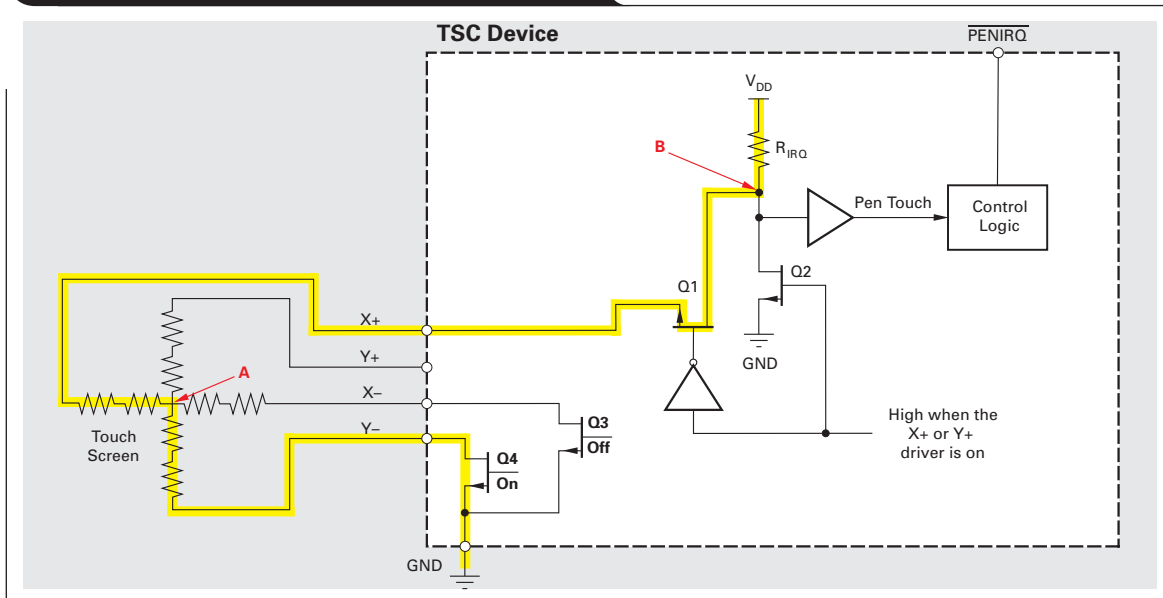

Table 1. $\overline{\text{PENIRQ}}$ operation (when enables)

System Condition	$\overline{\text{PENIRQ}}$ Circuit Status	Analog Interface Status	$\overline{\text{PENIRQ}}$ Status
No touch applied to the panel (the X and Y layers have no connection)	Q1 is on Q2 is off Voltage at B = $V_B = V_{DD}$ (no current flows because the X and Y layers have no connection)	$X+ = V_{DD}$ $X- = V_{DD}$ $Y+ = \text{GND}$ $Y- = \text{GND}$	$\overline{\text{PENIRQ}} \equiv V_{DD}$
Touch applied to the panel (the X and Y layers are connected at a point A)	Q1 is on Q2 is off $V_B = \text{Equation 1}$ (Current loop: $V_{DD} \rightarrow R_{\text{IRQ}} \rightarrow \mathbf{B} \rightarrow \mathbf{Q1} \rightarrow \mathbf{X+} \rightarrow \mathbf{A} \rightarrow \mathbf{Y-} \rightarrow \mathbf{Q4} \rightarrow \text{GND}$)	$X+ \approx V_B$ $X- \approx V_B$ $Y+ \approx \text{GND}$ $Y- \approx \text{GND}$	$\overline{\text{PENIRQ}} \approx \text{GND}$ If $V_B < V_{\text{Threshold}}$ or $\overline{\text{PENIRQ}} \approx V_{DD}$ If $V_B > V_{\text{Threshold}}$ Where the gate threshold is: $0.4 \times V_{DD} < V_{\text{Threshold}} < 0.6 \times V_{DD}$

With pressure applied to the touch panel, the X and Y layers of the touch panel connect at touch point A, and current flows from V_{DD} to ground through the touch panel. The voltage at point B in Figure 4 is then determined by the resistance divider between R_{IRQ} and R_{Touch} , as Equation 1 shows:

$$V_B \approx \frac{V_{DD}}{R_{\text{IRQ}} + R_{\text{Touch}}} \times R_{\text{Touch}}, \quad (1)$$

where R_{IRQ} is the TSC internal pullup resistor, R_{IRQ} is about 10 k Ω on the TSC2003, and approximately 51 k Ω or 90 k Ω (software-programmable) on the TSC2007.

R_{Touch} is the equivalent resistance between point B and ground, including:

- the Q1 ON resistance;
- the touch-panel X-layer resistance between the X+ to point A;
- the touching or pressure resistance (that is, the Z-layer) between the X and Y layers at point A;
- the touch-panel Y-layer resistance between point A to the Y-; and
- the Q4 ON resistance.

The yellow line in Figure 4 indicates the current flow when the panels are touching. The majority of the R_{Touch} is the third bullet above (the Z-layer resistance), that is, the touching resistance between the X and Y layers at point A. The other items are usually of much smaller resistance.

Table 1 details the expected (or correct) states and the status of the TSC200x $\overline{\text{PENIRQ}}$ circuit, the $\overline{\text{PENIRQ}}$ signal, and the TSC system analog interface, under the condition when the panel is not touched or when the panel is touched. From Table 1, we can see clearly that the key for $\overline{\text{PENIRQ}}$ to function correctly is the resistance ratio of R_{IRQ} and R_{Touch} with or without touch and under different levels of touch pressure. Therefore, the differences between R_{IRQ} , R_{Touch} , or $V_{\text{Threshold}}$ can affect $\overline{\text{PENIRQ}}$ behavior greatly.

When the $\overline{\text{PENIRQ}}$ circuitry works as expected, the proper analog interface connection can be confirmed if $\overline{\text{PENIRQ}}$ functions as shown in Figure 2 and Figure 3, without or with full I²C activity, respectively.

$\overline{\text{PENIRQ}}$ sensitivity

From the previous discussion, note that the $\overline{\text{PENIRQ}}$ responds to pressure on the touch panel (that is, $\overline{\text{PENIRQ}}$ goes low) only if the voltage V_B under the touch falls below the gate threshold $V_{\text{Threshold}}$; refer to Table 1. Because V_B is determined by the ratio of R_{IRQ} and R_{Touch} , the ohms of the touch panel R_{Touch} and the TSC internal R_{IRQ} are the keys to understanding $\overline{\text{PENIRQ}}$ behavior and establishing touch-detection sensitivity.

For most resistive TSC devices on the market today, R_{Touch} , when pressure is put on the panel, ranges from several hundred ohms to a couple of thousand ohms. Depending on the mechanical structure of the panel, R_{Touch} can be up to several hundred-thousand ohms with very weak pressure. As a result, with a low-to-moderate panel R_{Touch} value (that is, less than 10 k Ω), V_B can be much lower than $0.4 \times V_{DD}$ when the panel is touched, and so there is no problem for the $\overline{\text{PENIRQ}}$ to work corresponding to a panel touch on or off.

For example: If the panel resistance changes from infinite (no-touch or touch-off state) to 1500 Ω (touch-on state), V_B is:

$$\begin{aligned} V_B &\approx \frac{V_{DD}}{R_{\text{IRQ}} + R_{\text{Touch}}} \times R_{\text{Touch}} = \frac{V_{DD}}{51000 + 1500} \times 1500 \\ &= 0.029 \times V_{DD} \quad (\text{for } 51\text{-k}\Omega R_{\text{IRQ}} \text{ on TSC2007}). \end{aligned}$$

Similarly, $V_B \approx 0.016 \times V_{DD}$ for 90-k Ω R_{IRQ} on the TSC2007; or $V_B \approx 0.13 \times V_{DD}$ on the TSC2003 (where $R_{\text{IRQ}} = 10$ k Ω). In both these cases, V_B is much lower than the gate threshold; $\overline{\text{PENIRQ}}$ works well and performs as expected.

For very light or weak touch-on pressure, however, the panel R_{Touch} value may be high; in fact, R_{Touch} may be as high as 20 k Ω upon a weak touch. With such touch panels

and such weak touch, the TSC2003 would surely have trouble because its internal $\overline{\text{PENIRQ}}$ pull-up resistor R_{Touch} is relatively low (about 10 k Ω), and because the voltage at point B is:

$$V_B \approx \frac{V_{DD}}{R_{\text{IRQ}} + R_{\text{Touch}}} \times R_{\text{Touch}} = \frac{V_{DD}}{10000 + 20000} \times 20000 = 0.67 \times V_{DD}.$$

Obviously, the voltage $0.67 \times V_{DD}$ at V_B is too high, and it cannot trigger the $\overline{\text{PENIRQ}}$. You have to apply significant pressure on such a panel to allow the TSC2003 to sense the touch.

Under the same weak touch, however, the TSC2007 has a clear advantage. The problem described above on the TSC2003 cannot occur because the TSC2007 has a much higher internal pull-up resistor in its $\overline{\text{PENIRQ}}$ circuit. Under the previous same example, V_B on the TSC2007 is either $0.28 \times V_{DD}$ (for 51-k Ω R_{IRQ}) or $0.18 \times V_{DD}$ (for 90-k Ω R_{IRQ}); both values are much lower than the gate threshold. The $\overline{\text{PENIRQ}}$ works correctly and reliably even with a very weak touch.

For some touch panels, the R_{Touch} resistance under a very weak touch may be very high and very close to the resistance without any touch. For example, if R_{Touch} is approximately ≥ 100 k Ω , then the TSC2007, with $R_{\text{IRQ}} = 90$ k Ω , may still have difficulty detecting it, since from Equation 1, $V_B = 0.526 \times V_{DD}$.

$\overline{\text{PENIRQ}}$ transient state

If you monitor the TSC2007 $\overline{\text{PENIRQ}}$ signal, you may notice that when a touch remains on the panel and when the host is reading touch data (such as X, Y, Z1, or Z2), the $\overline{\text{PENIRQ}}$ may return high shortly and then go back to low again before the TSC sends out the touch data over the I²C bus. This situation is illustrated by Figure 5 and Figure 6.

To explain these types of glitches in the $\overline{\text{PENIRQ}}$, we must first understand the function of the switches Q1 and Q2 in the $\overline{\text{PENIRQ}}$ functional block diagram (see Figure 4).

In some older TSC devices, such as the ADS7843, it is a concern or problem that a so-called ADC Convert Error caused by the $\overline{\text{PENIRQ}}$ circuit may occur. Refer to the section, Operation of $\overline{\text{PENIRQ}}$, in Reference 4.

Figure 5. $\overline{\text{PENIRQ}}$ goes high briefly before touch data are sent via I²C

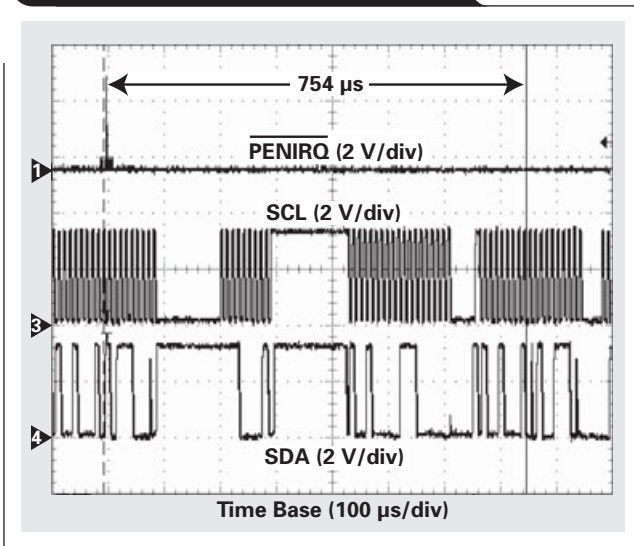

Figure 6. $\overline{\text{PENIRQ}}$ details while reading data

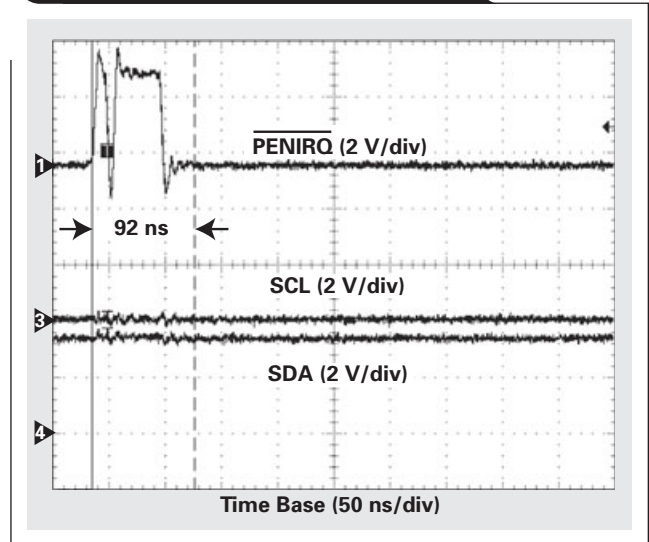
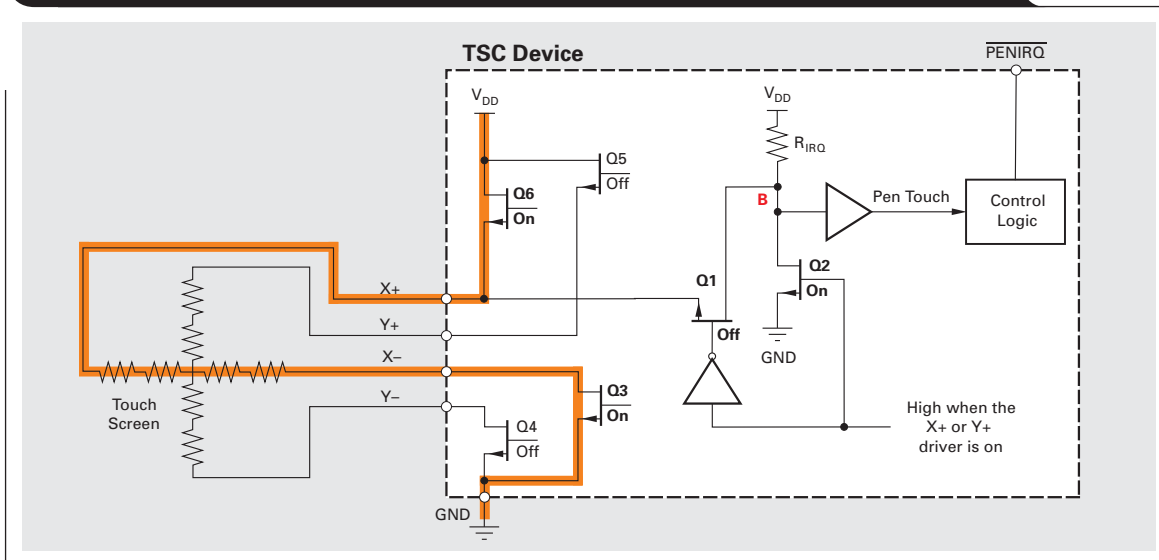

Figure 7. Disable $\overline{\text{PENIRQ}}$ when TSC X touch driver on (driver current in orange)

When a TSC driver is on (that is, the X driver is on), V_{DD} is added on the X+ and X- of the touch panel, and the driving current flows from X+ to X-. Therefore, to eliminate the ADC error caused by the internal $\overline{\text{PENIRQ}}$ circuit, the advanced $\overline{\text{PENIRQ}}$ detect circuit (see Figure 4) automatically turns off Q1 and turns on Q2. This means $\overline{\text{PENIRQ}}$ is disabled whenever the TSC X or Y driver is on, and the analog-to-digital converter is sampling the X data, as shown in Figure 7.

When a touch driver is on, the $\overline{\text{PENIRQ}}$ is disabled with Q1 off and Q2 on; there is no $\overline{\text{PENIRQ}}$ current that runs to the panel, and point B is connected to ground through Q2, as shown in Figure 7. The $\overline{\text{PENIRQ}}$ then remains low.

After finishing the touch-data acquisition process and turning off the touch driver (that is, Q3 and Q6 change from on to off), the TSC should again enable the $\overline{\text{PENIRQ}}$ by turning Q2 off and turning Q1 on. By the nature of material differences, there is a certain transient time when either Q1 or Q2 changes from on to off (or from off to on). This means there is a deviation or timing difference between Q1 and Q2 on the respective transient times. If Q2 has been turned off but Q1 has not yet been turned on completely, point B may neither be connected to X+ (through Q1) nor to ground (through Q2). Therefore, point B is pulled high by R_{IRQ} , during which time $\overline{\text{PENIRQ}}$ jumps high as shown in Figure 5 and Figure 6.

Such glitches at $\overline{\text{PENIRQ}}$ may become wider or narrower while the touch is moving at different locations. Nevertheless, they occur very briefly and quickly (usually in nano-seconds), and should not affect the $\overline{\text{PENIRQ}}$ function.

Power-up default state

To ensure that the TSC2003 $\overline{\text{PENIRQ}}$ is enabled after device power-up, the host may send a dummy read command to the TSC to enable the $\overline{\text{PENIRQ}}$; that is, the command sets the PD0 bit in the command byte to zero, or $\text{PD0} = 0$.

The TSC2007 $\overline{\text{PENIRQ}}$ default state after device power-up is automatically enabled. Thus, it is not necessary to implement any specific software command or initialization process with the TSC2007.

Conclusion

Understanding the function and operating principles of the pen-interrupt function, or $\overline{\text{PENIRQ}}$, can help users to quickly understand the TSC200x states, and therefore properly use the device and debug the system when needed. This article provides details on $\overline{\text{PENIRQ}}$ operation and behavior for the TSC2003 and TSC2007 devices. With information about how to make the sensitive $\overline{\text{PENIRQ}}$ more reliable, users can select the proper touch panel and TSC device for their specific applications.

Table 2. $\overline{\text{PENIRQ}}$ differences between TSC2003 and TSC2007

	TSC2003 $\overline{\text{PENIRQ}}$	TSC2007 $\overline{\text{PENIRQ}}$
Internal $\overline{\text{PENIRQ}}$ Pull-up R_{IRQ}	$R_{\text{IRQ}} = 10 \text{ k}\Omega$	$R_{\text{IRQ}} = 51 \text{ k}\Omega$ or $90 \text{ k}\Omega$, programmable
Power-up Default $\overline{\text{PENIRQ}}$ State	Recommended: Issue a software command to ensure that $\overline{\text{PENIRQ}}$ is enabled.	$\overline{\text{PENIRQ}}$ is automatically enabled after device power-up.

The $\overline{\text{PENIRQ}}$ circuit shown in Figure 4 detects touch on the panel when enabled, and the $\overline{\text{PENIRQ}}$ signal reflects whether the voltage at point B is greater or less than the gate threshold, thereby indicating the pen status.

Without the control of the host software, $\overline{\text{PENIRQ}}$ is always high when there is no touch and low when touched. With the host sends commands to read touch data, a TSC touch driver turns on to convert the touch data or turns off when the data conversion process completes. Therefore, the $\overline{\text{PENIRQ}}$ function must be disabled while the touch driver is on and enabled after the touch driver is off. As a result of the switch on/off transient timing, there may also be short glitches on the $\overline{\text{PENIRQ}}$ signal.

Note the slight differences between the $\overline{\text{PENIRQ}}$ on the TSC2003 and the TSC2007, as summarized in Table 2.

References

For more information related to this article, you can download an Acrobat Reader file at www-s.ti.com/sc/techlit/litnumber and replace "litnumber" with the **TI Lit. #** for the materials listed below.

Document Title	TI Lit. #
1. "TSC2003 I ² C Touch Screen Controller," data sheetsbas162
2. "TSC2007 1.2V to 3.6V, 12-Bit, Nanopower, 4-Wire Micro Touch Screen Controller with I ² C™ Interface," Datasheetsbas405
3. Fang, W. (July, 2007), "Migrating from TSC2003 to TSC2007," Application reportslaa364
4. Osgood, S., CK Ong, and R. Downs (April, 2000), "Touch Screen Controller Tips," Application Reportsbaa036

Related Web sites

dataconverter.ti.com

IMPORTANT NOTICE

Texas Instruments Incorporated and its subsidiaries (TI) reserve the right to make corrections, modifications, enhancements, improvements, and other changes to its products and services at any time and to discontinue any product or service without notice. Customers should obtain the latest relevant information before placing orders and should verify that such information is current and complete. All products are sold subject to TI's terms and conditions of sale supplied at the time of order acknowledgment.

TI warrants performance of its hardware products to the specifications applicable at the time of sale in accordance with TI's standard warranty. Testing and other quality control techniques are used to the extent TI deems necessary to support this warranty. Except where mandated by government requirements, testing of all parameters of each product is not necessarily performed.

TI assumes no liability for applications assistance or customer product design. Customers are responsible for their products and applications using TI components. To minimize the risks associated with customer products and applications, customers should provide adequate design and operating safeguards.

TI does not warrant or represent that any license, either express or implied, is granted under any TI patent right, copyright, mask work right, or other TI intellectual property right relating to any combination, machine, or process in which TI products or services are used. Information published by TI regarding third-party products or services does not constitute a license from TI to use such products or services or a warranty or endorsement thereof. Use of such information may require a license from a third party under the patents or other intellectual property of the third party, or a license from TI under the patents or other intellectual property of TI.

Reproduction of information in TI data books or data sheets is permissible only if reproduction is without alteration and is accompanied by all associated warranties, conditions, limitations, and notices. Reproduction of this information with alteration is an unfair and deceptive business practice. TI is not responsible or liable for such altered documentation.

Resale of TI products or services with statements different from or beyond the parameters stated by TI for that product or service voids all express and any implied warranties for the associated TI product or service and is an unfair and deceptive business practice. TI is not responsible or liable for any such statements.

Following are URLs where you can obtain information on other Texas Instruments products and application solutions:

Products

Amplifiers	amplifier.ti.com
Data Converters	dataconverter.ti.com
DSP	dsp.ti.com
Interface	interface.ti.com
Logic	logic.ti.com
Power Management	power.ti.com
Microcontrollers	microcontroller.ti.com

Applications

Audio	www.ti.com/audio
Automotive	www.ti.com/automotive
Broadband	www.ti.com/broadband
Digital control	www.ti.com/digitalcontrol
Military	www.ti.com/military
Optical Networking	www.ti.com/opticalnetwork
Security	www.ti.com/security
Telephony	www.ti.com/telephony
Video & Imaging	www.ti.com/video
Wireless	www.ti.com/wireless

TI Worldwide Technical Support

Internet

TI Semiconductor Product Information Center Home Page
support.ti.com

TI Semiconductor KnowledgeBase Home Page
support.ti.com/sc/knowledgebase

Product Information Centers

Americas

Phone	+1(972) 644-5580	Fax	+1(972) 927-6377
Internet/Email	support.ti.com/sc/pic/americas.htm		

Europe, Middle East, and Africa

Phone

European Free Call	00800-ASK-TEXAS (00800 275 83927)
--------------------	--------------------------------------

International	+49 (0) 8161 80 2121
---------------	----------------------

Russian Support	+7 (4) 95 98 10 701
-----------------	---------------------

Note: The European Free Call (Toll Free) number is not active in all countries. If you have technical difficulty calling the free call number, please use the international number above.

Fax	+(49) (0) 8161 80 2045
Internet	support.ti.com/sc/pic/euro.htm

Japan

Fax

International	+81-3-3344-5317	Domestic	0120-81-0036
---------------	-----------------	----------	--------------

Internet/Email	support.ti.com/sc/pic/japan.htm
----------------	--

International	support.ti.com/sc/pic/japan.htm
Domestic	www.tij.co.jp/pic

Asia

Phone

International	+886-2-23786800
---------------	-----------------

Domestic	Toll-Free Number
----------	------------------

Australia	1-800-999-084	Malaysia	1-800-80-3973
-----------	---------------	----------	---------------

China	800-820-8682	New Zealand	0800-446-934
-------	--------------	-------------	--------------

Hong Kong	800-96-5941	Philippines	1-800-765-7404
-----------	-------------	-------------	----------------

India	+91-80-41381665 (Toll)	Singapore	800-886-1028
-------	------------------------	-----------	--------------

Indonesia	001-803-8861-1006	Taiwan	0800-006800
-----------	-------------------	--------	-------------

Korea	080-551-2804	Thailand	001-800-886-0010
-------	--------------	----------	------------------

Fax	+886-2-2378-6808	Email	tiasia@ti.com
Internet	support.ti.com/sc/pic/asia.htm		ti-china@ti.com

C010208

Safe Harbor Statement: This publication may contain forward-looking statements that involve a number of risks and uncertainties. These "forward-looking statements" are intended to qualify for the safe harbor from liability established by the Private Securities Litigation Reform Act of 1995. These forward-looking statements generally can be identified by phrases such as TI or its management "believes," "expects," "anticipates," "foresees," "forecasts," "estimates" or other words or phrases of similar import. Similarly, such statements herein that describe the company's products, business strategy, outlook, objectives, plans, intentions or goals also are forward-looking statements. All such forward-looking statements are subject to certain risks and uncertainties that could cause actual results to differ materially from those in forward-looking statements. Please refer to TI's most recent Form 10-K for more information on the risks and uncertainties that could materially affect future results of operations. We disclaim any intention or obligation to update any forward-looking statements as a result of developments occurring after the date of this publication.

Trademarks: All trademarks are the property of their respective owners.

Mailing Address: Texas Instruments
Post Office Box 655303
Dallas, Texas 75265

© 2008 Texas Instruments Incorporated