

LP5811 Synchronous Boost 4-Channel RGBW LED Driver Register Map

Technical Reference Manual



Literature Number: SNVU925
OCTOBER 2024

Table of Contents



Read This First	5
About This Manual.....	5
Notational Conventions.....	5
Glossary.....	5
Related Documentation.....	5
Support Resources.....	5
1 Introduction/Feature Overview	6
1.1 Overview.....	6
2 Register Maps	8
2.1 Register Map Table.....	9
2.2 Device_Enable Registers.....	15
2.3 Config Registers.....	16
2.4 Command Registers.....	23
2.5 LED_Enable Registers.....	25
2.6 Fault_Clear Registers.....	26
2.7 Reset Registers.....	27
2.8 Manual_DC Registers.....	28
2.9 Manual_PWM Registers.....	31
2.10 Autonomous_DC Registers.....	34
2.11 LED_0_Autonomous_Animation Registers.....	37
2.12 LED_1_Autonomous_Animation Registers.....	53
2.13 LED_2_Autonomous_Animation Registers.....	69
2.14 LED_3_Autonomous_Animation Registers.....	85
2.15 Flag Registers.....	101
Revision History	106

This page intentionally left blank.



About This Manual

This Technical Reference Manual (TRM) details the register maps of LP5811.

The TRM should not be considered a substitute for the data sheet, rather a companion guide that should be used alongside the device-specific data sheet to understand the details to program the device. The primary purpose of the TRM is to abstract the programming registers of the device from the data manual. This allows the data sheet to outline the high-level features of the device without unnecessary information about register descriptions.

Notational Conventions

This document uses the following conventions.

- Hexadecimal numbers can be shown with the suffix h or the prefix 0x. For example, the following number is 40 hexadecimal (decimal 64): 40h or 0x40.
- Registers in this document are shown in figures and described in tables.
 - Each register figure shows a rectangle divided into fields that represent the fields of the register. Each field is labeled with its bit name, its beginning and ending bit numbers above, and its read/write properties with default reset value below. A legend explains the notation used for the properties.
 - Reserved bits in a register figure can have one of multiple meanings:
 - Not implemented on the device
 - Reserved for future device expansion
 - Reserved for TI testing
 - Reserved configurations of the device that are not supported
 - Writing nondefault values to the Reserved bits could cause unexpected behavior and should be avoided.

Glossary

[TI Glossary](#) This glossary lists and explains terms, acronyms, and definitions.

Related Documentation

For a complete listing of related documentation and development-support tools, visit the Texas Instruments website at <http://www.ti.com>.

SNVSCC4A *LP5811 Synchronous Boost 4-Channel RGBW LED Driver With Autonomous Control* describes the data sheet of the LP5811 device.

Support Resources

[TI E2E™ support forums](#) are an engineer's go-to source for fast, verified answers and design help — straight from the experts. Search existing answers or ask your own question to get the quick design help you need.

Linked content is provided "AS IS" by the respective contributors. They do not constitute TI specifications and do not necessarily reflect TI's views; see TI's [Terms of Use](#).

Trademarks

TI E2E™ is a trademark of Texas Instruments.
All trademarks are the property of their respective owners.



1.1 Overview

The LP5811 is a synchronous boost 4-Channel RGBW LED driver with autonomous animation engine control. The device can support 1.8 V minimum start-up voltage and 0.5 V to 5.5 V input voltage range during operation. The integrated synchronous boost converter can output 3 V to 5.5 V, to provide enough forward voltage of LEDs.

The LP5811 has ultra-low operation current at active mode, consuming 0.4 mA when LED maximum current setting is 25.5 mA. If all LEDs are turned off, the device enters standby state to reduce power consumption with data retained. When 'chip_enable' bit setting is 0, initial state is entered with minimum power consumption to save power.

The LP5811 supports both analog dimming and PWM dimming. In analog dimming, the output current of each LED can be adjusted with 256 steps. In PWM dimming, the integrated 8-bit configurable PWM generator enables smooth brightness dimming control. Optional exponential PWM dimming can be activated for individual LED to achieve a human-eye-friendly visual performance.

The LP5811 integrates autonomous animation engine, with no need for brightness control commands from controller. Each LED has an individual animation engine which can be configured through the related registers. The device can generate a 6 MHz clock signal, which synchronizes the lighting effects among multiple devices.

The LP5811 has 4 different material versions with different I2C chip address. Up to 4 LP581x devices can be connected to the same I2C bus and controlled individually.

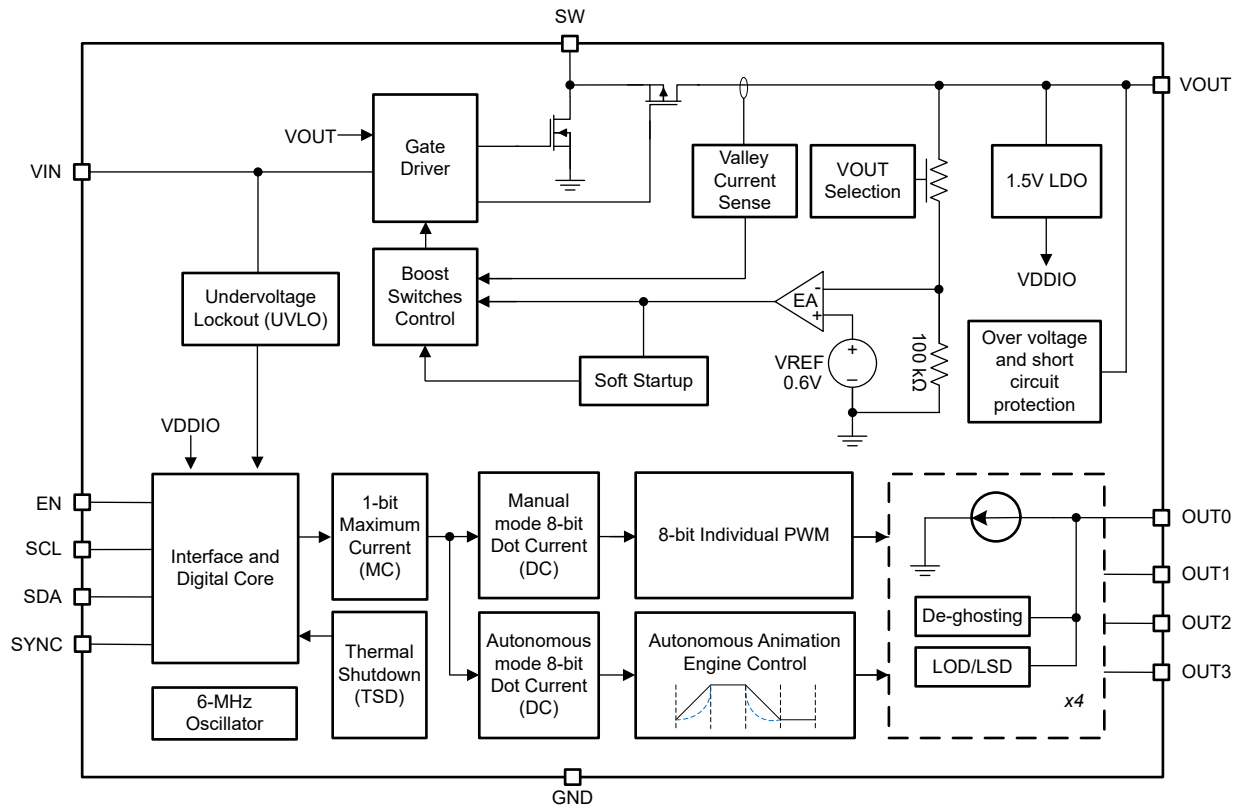

Figure 1-1. Device Block Diagram



This section shows the detailed register maps of LP5811.

2.1 Register Map Table	9
2.2 Device_Enable Registers	15
2.3 Config Registers	16
2.4 Command Registers	23
2.5 LED_Enable Registers	25
2.6 Fault_Clear Registers	26
2.7 Reset Registers	27
2.8 Manual_DC Registers	28
2.9 Manual_PWM Registers	31
2.10 Autonomous_DC Registers	34
2.11 LED_0_Autonomous_Animation Registers	37
2.12 LED_1_Autonomous_Animation Registers	53
2.13 LED_2_Autonomous_Animation Registers	69
2.14 LED_3_Autonomous_Animation Registers	85
2.15 Flag Registers	101

2.1 Register Map Table

This section provides a summary of the register maps.

Table 2-1. Register Section/Block Access Type Codes

Access Type	Code	Description
Read Type		
R	R	Read
RC	R C	Read to Clear
R-0	R -0	Read Returns 0
Write Type		
W	W	Write
W1C	W 1C	W 1 to clear
Reset or Default Value		
-n		Value after reset or the default value

Register Acronym	Address	Type	D7	D6	D5	D4	D3	D2	D1	D0	Default	
Device_Enable Register												
Chip_en	000h	R/W	Reserved							chip_en	00h	
Config Registers												
Dev_Config_0	001h	R/W	Reserved			boost_vout				max_curr ent	00h	
Dev_Config_1	002h	R/W	pwm_fre	led_mode		Reserved				00h		
Dev_Config_2	003h	R/W	Reserved									E4h
Dev_Config_3	004h	R/W	Reserved					auto_en_3	auto_en_2	auto_en_1	auto_en_0	00h
Dev_Config_4	005h	R/W	Reserved									00h
Dev_Config_5	006h	R/W	Reserved					exp_en_3	exp_en_2	exp_en_1	exp_en_0	00h
Dev_Config_6	007h	R/W	Reserved									00h
Dev_Config_7	008h	R/W	phase_align_3		phase_align_2		phase_align_1		phase_align_0		00h	
Dev_Config_8	009h	R/W	Reserved									00h
Dev_Config_9	00Ah	R/W	Reserved									00h
Dev_Config_10	00Bh	R/W	Reserved									00h
Dev_Config_11	00Ch	R/W	Reserved						vsync_ou t_en	blank_time		00h
Dev_Config_12	00Dh	R/W	vmid_sel		clamp_se l	clamp_di s	lod_actio n	lsd_actio n	lsd_threshold		08h	
Command Registers												
CMD_Update	010h	W1C	update_command									00h
CMD_Start	011h	W1C	start_command									00h
CMD_Stop	012h	W1C	stop_command									00h
CMD_Pause	013h	W1C	pause_command									00h
CMD_Continue	014h	W1C	continue_command									00h
led_enable Registers												
led_en_1	020h	R/W	Reserved				led_en_3	led_en_2	led_en_1	led_en_0	00h	
led_en_2	021h	R/W	Reserved									00h
Fault_Clear Register												

Register Acronym	Address	Type	D7	D6	D5	D4	D3	D2	D1	D0	Default	
Fault_Clear	022h	W1C	Reserved					tsd_clear	lsd_clear	lod_clear	00h	
Reset Register												
Reset	023h	W1C	sw_reset								00h	
Manual_DC Registers												
Manual_DC_0	030h	R/W	manual_dc_0								00h	
Manual_DC_1	031h	R/W	manual_dc_1								00h	
Manual_DC_2	032h	R/W	manual_dc_2								00h	
Manual_DC_3	033h	R/W	manual_dc_3								00h	
Manual_PWM Registers												
Manual_PWM_0	040h	R/W	manual_pwm_0								00h	
Manual_PWM_1	041h	R/W	manual_pwm_1								00h	
Manual_PWM_2	042h	R/W	manual_pwm_2								00h	
Manual_PWM_3	043h	R/W	manual_pwm_3								00h	
Autonomous_DC Registers												
Auto_DC_0	050h	R/W	auto_dc_0								00h	
Auto_DC_1	051h	R/W	auto_dc_1								00h	
Auto_DC_2	052h	R/W	auto_dc_2								00h	
Auto_DC_3	053h	R/W	auto_dc_3								00h	
LED_0_Autonomous_Animation Registers												
LED_0_Auto_Pause	080h	R/W	led_0_pause_start				led_0_pause_stop				00h	
LED_0_Auto_Playback	081h	R/W	Reserved		led_0_aeu_num		LED_0_pt			00h		
LED_0_AEU1_PWM_1	082h	R/W	led_0_aeu1_pwm1								00h	
LED_0_AEU1_PWM_2	083h	R/W	led_0_aeu1_pwm2								00h	
LED_0_AEU1_PWM_3	084h	R/W	led_0_aeu1_pwm3								00h	
LED_0_AEU1_PWM_4	085h	R/W	led_0_aeu1_pwm4								00h	
LED_0_AEU1_PWM_5	086h	R/W	led_0_aeu1_pwm5								00h	
LED_0_AEU1_T12	087h	R/W	led_0_aeu1_t2				led_0_aeu1_t1				00h	
LED_0_AEU1_T34	088h	R/W	led_0_aeu1_t4				led_0_aeu1_t3				00h	
LED_0_AEU1_Playback	089h	R/W	Reserved							led_0_aeu1_pt		00h
LED_0_AEU2_PWM_1	08Ah	R/W	led_0_aeu2_pwm1								00h	
LED_0_AEU2_PWM_2	08Bh	R/W	led_0_aeu2_pwm2								00h	
LED_0_AEU2_PWM_3	08Ch	R/W	led_0_aeu2_pwm3								00h	
LED_0_AEU2_PWM_4	08Dh	R/W	led_0_aeu2_pwm4								00h	
LED_0_AEU2_PWM_5	08Eh	R/W	led_0_aeu2_pwm5								00h	
LED_0_AEU2_T12	08Fh	R/W	led_0_aeu2_t2				led_0_aeu2_t1				00h	
LED_0_AEU2_T34	090h	R/W	led_0_aeu2_t4				led_0_aeu2_t3				00h	

Register Acronym	Address	Type	D7	D6	D5	D4	D3	D2	D1	D0	Default	
LED_0_AEU2_Play back	091h	R/W	Reserved						led_0_aeu2_pt		00h	
LED_0_AEU3_PWM_1	092h	R/W	led_0_aeu3_pwm1									00h
LED_0_AEU3_PWM_2	093h	R/W	led_0_aeu3_pwm2									00h
LED_0_AEU3_PWM_3	094h	R/W	led_0_aeu3_pwm3									00h
LED_0_AEU3_PWM_4	095h	R/W	led_0_aeu3_pwm4									00h
LED_0_AEU3_PWM_5	096h	R/W	led_0_aeu3_pwm5									00h
LED_0_AEU3_T12	097h	R/W	led_0_aeu3_t2				led_0_aeu3_t1				00h	
LED_0_AEU3_T34	098h	R/W	led_0_aeu3_t4				led_0_aeu3_t3				00h	
LED_0_AEU3_Play back	099h	R/W	Reserved						led_0_aeu3_pt		00h	
LED_1 Autonomous Animation Registers												
LED_1_Auto_Pause	09Ah	R/W	led_1_pause_start				led_1_pause_stop				00h	
LED_1_Auto_Playback	09Bh	R/W	Reserved		led_1_aeu_num		led_1_pt			00h		
LED_1_AEU1_PWM_1	09Ch	R/W	led_1_aeu1_pwm1									00h
LED_1_AEU1_PWM_2	09Dh	R/W	led_1_aeu1_pwm2									00h
LED_1_AEU1_PWM_3	09Eh	R/W	led_1_aeu1_pwm3									00h
LED_1_AEU1_PWM_4	09Fh	R/W	led_1_aeu1_pwm4									00h
LED_1_AEU1_PWM_5	0A0h	R/W	led_1_aeu1_pwm5									00h
LED_1_AEU1_T12	0A1h	R/W	led_1_aeu1_t2				led_1_aeu1_t1				00h	
LED_1_AEU1_T34	0A2h	R/W	led_1_aeu1_t4				led_1_aeu1_t3				00h	
LED_1_AEU1_Play back	0A3h	R/W	Reserved						led_1_aeu1_pt		00h	
LED_1_AEU2_PWM_1	0A4h	R/W	led_1_aeu2_pwm1									00h
LED_1_AEU2_PWM_2	0A5h	R/W	led_1_aeu2_pwm2									00h
LED_1_AEU2_PWM_3	0A6h	R/W	led_1_aeu2_pwm3									00h
LED_1_AEU2_PWM_4	0A7h	R/W	led_1_aeu2_pwm4									00h
LED_1_AEU2_PWM_5	0A8h	R/W	led_1_aeu2_pwm5									00h
LED_1_AEU2_T12	0A9h	R/W	led_1_aeu1_t2				led_1_aeu1_t1				00h	
LED_1_AEU2_T34	0AAh	R/W	led_1_aeu1_t4				led_1_aeu1_t3				00h	
LED_1_AEU2_Play back	0ABh	R/W	Reserved						led_1_aeu2_pt		00h	
LED_1_AEU3_PWM_1	0ACh	R/W	led_1_aeu3_pwm1									00h
LED_1_AEU3_PWM_2	0ADh	R/W	led_1_aeu3_pwm2									00h

Register Acronym	Address	Type	D7	D6	D5	D4	D3	D2	D1	D0	Default	
LED_1_AEU3_PWM_3	0AEh	R/W	led_1_aeu3_pwm3									00h
LED_1_AEU3_PWM_4	0AFh	R/W	led_1_aeu3_pwm4									00h
LED_1_AEU3_PWM_5	0B0h	R/W	led_1_aeu3_pwm5									00h
LED_1_AEU3_T12	0B1h	R/W	led_1_aeu3_t2				led_1_aeu3_t1				00h	
LED_1_AEU3_T34	0B2h	R/W	led_1_aeu3_t4				led_1_aeu3_t3				00h	
LED_1_AEU3_Play back	0B3h	R/W	Reserved							led_1_aeu3_pt		00h
LED_2 Autonomous Animation Registers												
LED_2_Auto_Pause	0B4h	R/W	led_2_pause_start				led_2_pause_stop				00h	
LED_2_Auto_Playback	0B5h	R/W	Reserved		led_2_aeu_num		led_2_pt			00h		
LED_2_AEU1_PWM_1	0B6h	R/W	led_2_aeu1_pwm1									00h
LED_2_AEU1_PWM_2	0B7h	R/W	led_2_aeu1_pwm2									00h
LED_2_AEU1_PWM_3	0B7h	R/W	led_2_aeu1_pwm3									00h
LED_2_AEU1_PWM_4	0B9h	R/W	led_2_aeu1_pwm4									00h
LED_2_AEU1_PWM_5	0BAh	R/W	led_2_aeu1_pwm5									00h
LED_2_AEU1_T12	0BBh	R/W	led_2_aeu1_t2				led_2_aeu1_t1				00h	
LED_2_AEU1_T34	0BCh	R/W	led_2_aeu1_t4				led_2_aeu1_t3				00h	
LED_2_AEU1_Play back	0BDh	R/W	Reserved							led_2_aeu1_pt		00h
LED_2_AEU2_PWM_1	0BEh	R/W	led_2_aeu2_pwm1									00h
LED_2_AEU2_PWM_2	0BFh	R/W	led_2_aeu2_pwm2									00h
LED_2_AEU2_PWM_3	0C0h	R/W	led_2_aeu2_pwm3									00h
LED_2_AEU2_PWM_4	0C1h	R/W	led_2_aeu2_pwm4									00h
LED_2_AEU2_PWM_5	0C2h	R/W	led_2_aeu2_pwm5									00h
LED_2_AEU2_T12	0C3h	R/W	led_2_aeu2_t2				led_2_aeu2_t1				00h	
LED_2_AEU2_T34	0C4h	R/W	led_2_aeu2_t4				led_2_aeu2_t3				00h	
LED_2_AEU2_Play back	0C5h	R/W	Reserved							led_2_aeu2_pt		00h
LED_2_AEU3_PWM_1	0C6h	R/W	led_2_aeu3_pwm1									00h
LED_2_AEU3_PWM_2	0C7h	R/W	led_2_aeu3_pwm2									00h
LED_2_AEU3_PWM_3	0C8h	R/W	led_2_aeu3_pwm3									00h
LED_2_AEU3_PWM_4	0C9h	R/W	led_2_aeu3_pwm4									00h
LED_2_AEU3_PWM_5	0CAh	R/W	led_2_aeu3_pwm5									00h

Register Acronym	Address	Type	D7	D6	D5	D4	D3	D2	D1	D0	Default	
LED_2_AEU3_T12	0CBh	R/W	led_2_aeu3_t2				led_2_aeu3_t1					00h
LED_2_AEU3_T34	0CCh	R/W	led_2_aeu3_t4				led_2_aeu3_t3					00h
LED_2_AEU3_Play back	0CDh	R/W	Reserved							led_2_aeu3_pt		00h
LED_3 Autonomous Animation Registers												
LED_3_Auto_Paus e	0CEh	R/W	led_3_pause_start				led_3_pause_stop					00h
LED_3_Auto_Playb ack	0CFh	R/W	Reserved		led_3_aeu_num		led_3_pt				00h	
LED_3_AEU1_PWM _1	0D0h	R/W	led_3_aeu1_pwm1									00h
LED_3_AEU1_PWM _2	0D1h	R/W	led_3_aeu1_pwm2									00h
LED_3_AEU1_PWM _3	0D2h	R/W	led_3_aeu1_pwm3									00h
LED_3_AEU1_PWM _4	0D3h	R/W	led_3_aeu1_pwm4									00h
LED_3_AEU1_PWM _5	0D4h	R/W	led_3_aeu1_pwm5									00h
LED_3_AEU1_T12	0D5h	R/W	led_3_aeu1_t2				led_3_aeu1_t1					00h
LED_3_AEU1_T34	0D6h	R/W	led_3_aeu1_t4				led_3_aeu1_t3					00h
LED_3_AEU1_Play back	0D7h	R/W	Reserved							led_3_aeu1_pt		00h
LED_3_AEU2_PWM _1	0D8h	R/W	led_3_aeu2_pwm1									00h
LED_3_AEU2_PWM _2	0D9h	R/W	led_3_aeu2_pwm2									00h
LED_3_AEU2_PWM _3	0DAh	R/W	led_3_aeu2_pwm3									00h
LED_3_AEU2_PWM _4	0DBh	R/W	led_3_aeu2_pwm4									00h
LED_3_AEU2_PWM _5	0DCh	R/W	led_3_aeu2_pwm5									00h
LED_3_AEU2_T12	0DDh	R/W	led_3_aeu2_t2				led_3_aeu2_t1					00h
LED_3_AEU2_T34	0DEh	R/W	led_3_aeu2_t4				led_3_aeu2_t3					00h
LED_3_AEU2_Play back	0DFh	R/W	Reserved							led_3_aeu2_pt		00h
LED_3_AEU3_PWM _1	0E0h	R/W	led_3_aeu3_pwm1									00h
LED_3_AEU3_PWM _2	0E1h	R/W	led_3_aeu3_pwm2									00h
LED_3_AEU3_PWM _3	0E2h	R/W	led_3_aeu3_pwm3									00h
LED_3_AEU3_PWM _4	0E3h	R/W	led_3_aeu3_pwm4									00h
LED_3_AEU3_PWM _5	0E4h	R/W	led_3_aeu3_pwm5									00h
LED_3_AEU3_T12	0E5h	R/W	led_3_aeu3_t2				led_3_aeu3_t1					00h
LED_3_AEU3_T34	0E6h	R/W	led_3_aeu3_t4				led_3_aeu3_t3					00h
LED_3_AEU3_Play back	0E7h	R/W	Reserved							led_3_aeu3_pt		00h
Flag Registers												

Register Acronym	Address	Type	D7	D6	D5	D4	D3	D2	D1	D0	Default
TSD_Config_Status	300h	R	Reserved						tsd_Statu s	config_er r_status	00h
LOD_Status_0	301h	R	Reserved				lod_statu s_3	lod_statu s_2	lod_statu s_1	lod_statu s_0	00h
LOD_Status_1	302h	R	Reserved								00h
LSD_Status_0	303h	R	Reserved				lsd_statu s_3	lsd_statu s_2	lsd_statu s_1	lsd_statu s_0	00h
LSD_Status_1	304h	R	Reserved								00h
Auto_PWM_0	305h	R	pwm_auto_0								00h
Auto_PWM_1	306h	R	pwm_auto_1								00h
Auto_PWM_2	307h	R	pwm_auto_2								00h
Auto_PWM_3	308h	R	pwm_auto_3								00h
AEP_Status_0	315h	R	Reserved		aep_status_1			aep_status_0			3Fh
AEP_Status_1	316h	R	Reserved		aep_status_3			aep_status_2			3Fh

2.2 Device_Enable Registers

Table 2-2 lists the memory-mapped registers for the Device_Enable registers. All register offset addresses not listed in Table 2-2 should be considered as reserved locations and the register contents should not be modified.

Table 2-2. DEVICE_ENABLE Registers

Offset	Acronym	Register Name	Section
0h	Chip_EN	Enable the internal circuits	Go

2.2.1 Chip_EN Register (Offset = 0h) [Reset = 00h]

Chip_EN is shown in Figure 2-1 and described in Table 2-3.

Return to the [Summary Table](#).

Figure 2-1. Chip_EN Register

7	6	5	4	3	2	1	0
RESERVED							chip_en
R-0h							R/W-0h

Table 2-3. Chip_EN Register Field Descriptions

Bit	Field	Type	Reset	Description
7-1	RESERVED	R	0h	Reserved
0	chip_en	R/W	0h	Enable the internal circuits 0h = Disable 1h = Enable

2.3 Config Registers

Table 2-4 lists the memory-mapped registers for the Config registers. All register offset addresses not listed in Table 2-4 should be considered as reserved locations and the register contents should not be modified.

Table 2-4. CONFIG Registers

Offset	Acronym	Register Name	Section
1h	Dev_Config_0	Device configuration register 0, including max current sinks current and boost output settings	Go
2h	Dev_Config_1	Device configuration register 1, including LED configuration and PWM frequency settings	Go
3h	Dev_Config_2	Device configuration register 2, reserved	
4h	Dev_Config_3	Device configuration register 3, including autonomous enable settings for LED_0 to LED_3	Go
5h	Dev_Config_4	Device configuration register 4, reserved	
6h	Dev_Config_5	Device configuration register 5, including exponential curve enable settings for LED_0 to LED_3	Go
7h	Dev_Config_6	Device configuration register 6, reserved	
8h	Dev_Config_7	Device configuration register 7, including phase shift settings for LED_0 to LED_3	Go
9h	Dev_Config_8	Device configuration register 8, reserved	
Ah	Dev_Config_9	Device configuration register 9, reserved	
Bh	Dev_Config_10	Device configuration register 10, reserved	
Ch	Dev_Config_11	Device configuration register 11, including line change time and VSYNC settings	Go
Dh	Dev_Config_12	Device configuration register 12, including threshold and action settings for LOD, LSD and clamp	Go

2.3.1 Dev_Config_0 Register (Offset = 1h) [Reset = 00h]

Dev_Config_0 is shown in Figure 2-2 and described in Table 2-5.

Return to the [Summary Table](#).

Figure 2-2. Dev_Config_0 Register

7	6	5	4	3	2	1	0
RESERVED		boost_vout					max_current
R-0h		R/W-0h					R/W-0h

Table 2-5. Dev_Config_0 Register Field Descriptions

Bit	Field	Type	Reset	Description
7-6	RESERVED	R	0h	Reserved
5-1	boost_vout	R/W	0h	Boost output voltage with 0.1 V step from 3 V to 5.5 V 0h = 3 V 1h = 3.1 V 2h = 3.2 V 3h = 3.3 V 4h = 3.4 V ... 18h = 5.4 V 19h = 5.5 V 2Ah = 5.5 V (max VOUT, values above 2Ah have the same effect) ... 1Fh = 5.5V

Table 2-5. Dev_Config_0 Register Field Descriptions (continued)

Bit	Field	Type	Reset	Description
0	max_current	R/W	0h	Max output current setting 0h = 25.5mA 1h = 51mA

2.3.2 Dev_Config_1 Register (Offset = 2h) [Reset = 00h]

Dev_Config_1 is shown in [Figure 2-3](#) and described in [Table 2-6](#).

Return to the [Summary Table](#).

Figure 2-3. Dev_Config_1 Register

7	6	5	4	3	2	1	0
pwm_fre	led_mode		RESERVED				
R/W-0h	R/W-0h		R-0h				

Table 2-6. Dev_Config_1 Register Field Descriptions

Bit	Field	Type	Reset	Description
7	pwm_fre	R/W	0h	PWM dimming frequency setting 0h = 24kHz 1h = 12kHz
6-4	led_mode	R/W	0h	LED mode configuration 0h = Direct drive mode
3-0	RESERVED	R	0h	Reserved

2.3.3 Dev_Config_2 Register (Offset = 3h) [Reset = 00h]

Dev_Config_2 is shown in [Figure 2-4](#) and described in [Table 2-7](#).

Return to the [Summary Table](#).

Figure 2-4. Dev_Config_2 Register

7	6	5	4	3	2	1	0
RESERVED							
R-0h							

Table 2-7. Dev_Config_2 Register Field Descriptions

Bit	Field	Type	Reset	Description
7-0	RESERVED	R	0h	Reserved

2.3.4 Dev_Config_3 Register (Offset = 4h) [Reset = 00h]

Dev_Config_3 is shown in [Figure 2-5](#) and described in [Table 2-8](#).

Return to the [Summary Table](#).

Figure 2-5. Dev_Config_3 Register

7	6	5	4	3	2	1	0
RESERVED				auto_en_3	auto_en_2	auto_en_1	auto_en_0
R-0h				R/W-0h	R/W-0h	R/W-0h	R/W-0h

Table 2-8. Dev_Config_3 Register Field Descriptions

Bit	Field	Type	Reset	Description
7-4	RESERVED	R	0h	Reserved
3	auto_en_3	R/W	0h	LED_3 autonomous control enable 0h = Disabled, LED in manual mode 1h = Enabled, LED in autonomous mode
2	auto_en_2	R/W	0h	LED_2 autonomous control enable 0h = Disabled, LED in manual mode 1h = Enabled, LED in autonomous mode
1	auto_en_1	R/W	0h	LED_1 autonomous control enable 0h = Disabled, LED in manual mode 1h = Enabled, LED in autonomous mode
0	auto_en_0	R/W	0h	LED_0 autonomous control enable 0h = Disabled, LED in manual mode 1h = Enabled, LED in autonomous mode

2.3.5 Dev_Config_4 Register (Offset = 5h) [Reset = 00h]

Dev_Config_4 is shown in [Figure 2-6](#) and described in [Table 2-9](#).

Return to the [Summary Table](#).

Figure 2-6. Dev_Config_4 Register

7	6	5	4	3	2	1	0
RESERVED							
R-0h							

Table 2-9. Dev_Config_4 Register Field Descriptions

Bit	Field	Type	Reset	Description
7-0	RESERVED	R	0h	Reserved

2.3.6 Dev_Config_5 Register (Offset = 6h) [Reset = 00h]

Dev_Config_5 is shown in [Figure 2-7](#) and described in [Table 2-10](#).

Return to the [Summary Table](#).

Figure 2-7. Dev_Config_5 Register

7	6	5	4	3	2	1	0
RESERVED				exp_en_3	exp_en_2	exp_en_1	exp_en_0
R-0h				R/W-0h	R/W-0h	R/W-0h	R/W-0h

Table 2-10. Dev_Config_5 Register Field Descriptions

Bit	Field	Type	Reset	Description
7-4	RESERVED	R	0h	Reserved
3	exp_en_3	R/W	0h	LED_3 exponential dimming enable 0h = Disabled, LED PWM dimming with linear curve 1h = Enabled, LED PWM dimming with exponential curve
2	exp_en_2	R/W	0h	LED_2 exponential dimming enable 0h = Disabled, LED PWM dimming with linear curve 1h = Enabled, LED PWM dimming with exponential curve

Table 2-10. Dev_Config_5 Register Field Descriptions (continued)

Bit	Field	Type	Reset	Description
1	exp_en_1	R/W	0h	LED_1 exponential dimming enable 0h = Disabled, LED PWM dimming with linear curve 1h = Enabled, LED PWM dimming with exponential curve
0	exp_en_0	R/W	0h	LED_0 exponential dimming enable 0h = Disabled, LED PWM dimming with linear curve 1h = Enabled, LED PWM dimming with exponential curve

2.3.7 Dev_Config_6 Register (Offset = 7h) [Reset = 00h]

Dev_Config_6 is shown in [Figure 2-8](#) and described in [Table 2-11](#).

Return to the [Summary Table](#).

Figure 2-8. Dev_Config_6 Register

7	6	5	4	3	2	1	0
RESERVED							
R-0h							

Table 2-11. Dev_Config_6 Register Field Descriptions

Bit	Field	Type	Reset	Description
7-0	RESERVED	R	0h	Reserved

2.3.8 Dev_Config_7 Register (Offset = 8h) [Reset = 00h]

Dev_Config_7 is shown in [Figure 2-9](#) and described in [Table 2-12](#).

Return to the [Summary Table](#).

Figure 2-9. Dev_Config_7 Register

7	6	5	4	3	2	1	0
phase_align_3		phase_align_2		phase_align_1		phase_align_0	
R/W-0h		R/W-0h		R/W-0h		R/W-0h	

Table 2-12. Dev_Config_7 Register Field Descriptions

Bit	Field	Type	Reset	Description
7-6	phase_align_3	R/W	0h	LED_3 PWM phase align method 0h = Forward align 1h = Forward align 2h = Middle align 3h = Backward align
5-4	phase_align_2	R/W	0h	LED_2 PWM phase align method 0h = Forward align 1h = Forward align 2h = Middle align 3h = Backward align
3-2	phase_align_1	R/W	0h	LED_1 PWM phase align method 0h = Forward align 1h = Forward align 2h = Middle align 3h = Backward align

Table 2-12. Dev_Config_7 Register Field Descriptions (continued)

Bit	Field	Type	Reset	Description
1-0	phase_align_0	R/W	0h	LED_0 PWM phase align method 0h = Forward align 1h = Forward align 2h = Middle align 3h = Backward align

2.3.9 Dev_Config_8 Register (Offset = 9h) [Reset = 00h]

Dev_Config_8 is shown in [Figure 2-10](#) and described in [Table 2-13](#).

Return to the [Summary Table](#).

Figure 2-10. Dev_Config_8 Register

7	6	5	4	3	2	1	0
RESERVED							
R-0h							

Table 2-13. Dev_Config_8 Register Field Descriptions

Bit	Field	Type	Reset	Description
7-0	RESERVED	R	0h	Reserved

2.3.10 Dev_Config_9 Register (Offset = Ah) [Reset = 00h]

Dev_Config_9 is shown in [Figure 2-11](#) and described in [Table 2-14](#).

Return to the [Summary Table](#).

Figure 2-11. Dev_Config_9 Register

7	6	5	4	3	2	1	0
RESERVED							
R-0h							

Table 2-14. Dev_Config_9 Register Field Descriptions

Bit	Field	Type	Reset	Description
7-0	RESERVED	R	0h	Reserved

2.3.11 Dev_Config_10 Register (Offset = Bh) [Reset = 00h]

Dev_Config_10 is shown in [Figure 2-12](#) and described in [Table 2-15](#).

Return to the [Summary Table](#).

Figure 2-12. Dev_Config_10 Register

7	6	5	4	3	2	1	0
RESERVED							
R-0h							

Table 2-15. Dev_Config_10 Register Field Descriptions

Bit	Field	Type	Reset	Description
7-0	RESERVED	R	0h	Reserved

2.3.12 Dev_Config_11 Register (Offset = Ch) [Reset = 00h]

Dev_Config_11 is shown in [Figure 2-13](#) and described in [Table 2-16](#).

Return to the [Summary Table](#).

Figure 2-13. Dev_Config_11 Register

7	6	5	4	3	2	1	0
RESERVED					vsync_out_en	blank_time	
R-0h					R/W-0h	R/W-0h	

Table 2-16. Dev_Config_11 Register Field Descriptions

Bit	Field	Type	Reset	Description
7-3	RESERVED	R	0h	Reserved
2	vsync_out_en	R/W	0h	Vsync used as output to export internal oscillator clock 0h = Vsync is input 1h = Vsync is output
1-0	blank_time	R/W	0h	Line change time 0h = 1us 1h = 1.3us 2h = 1.7us 3h = 2us

2.3.13 Dev_Config_12 Register (Offset = Dh) [Reset = 08h]

Dev_Config_12 is shown in [Figure 2-14](#) and described in [Table 2-17](#).

Return to the [Summary Table](#).

Figure 2-14. Dev_Config_12 Register

7	6	5	4	3	2	1	0
vmid_sel	clamp_sel	clamp_dis	lod_action	lsd_action	lsd_threshold		
R/W-0h	R/W-0h	R/W-0h	R/W-1h	R/W-0h	R/W-0h		

Table 2-17. Dev_Config_12 Register Field Descriptions

Bit	Field	Type	Reset	Description
7-6	vmid_sel	R/W	0h	Clamp voltage selection 0h = VOUT-1.1V 1h = VOUT-1.3V 2h = VOUT-1.5V 3h = VOUT-1.7V
5	clamp_sel	R/W	0h	Clamp behavior selection 0h = Clamp the OUTs only during line change time 1h = Clamp the OUTs once current sink turns off
4	clamp_dis	R/W	0h	Clamp behavior disable 0h = Enable clamp 1h = Disable clamp
3	lod_action	R/W	1h	Action when LED open fault happens 0h = No action 1h = Shutdown current sink
2	lsd_action	R/W	0h	Action when LED short fault happens 0h = No action 1h = All OUTs shut down

Table 2-17. Dev_Config_12 Register Field Descriptions (continued)

Bit	Field	Type	Reset	Description
1-0	lsd_threshold	R/W	0h	LSD threshold 0h = 0.35 * VOUT 1h = 0.45 * VOUT 2h = 0.55 * VOUT 3h = 0.65 * VOUT

2.4 Command Registers

Table 2-18 lists the memory-mapped registers for the Command registers. All register offset addresses not listed in Table 2-18 should be considered as reserved locations and the register contents should not be modified.

Table 2-18. COMMAND Registers

Offset	Acronym	Register Name	Section
10h	CMD_Update	Configuration update command	Go
11h	CMD_Start	Autonomous animation start command	Go
12h	CMD_Stop	Autonomous animation stop command	Go
13h	CMD_Pause	Autonomous animation pause command	Go
14h	CMD_Continue	Autonomous animation continue command	Go

2.4.1 CMD_Update Register (Offset = 10h) [Reset = 00h]

CMD_Update is shown in Figure 2-15 and described in Table 2-19.

Return to the [Summary Table](#).

Figure 2-15. CMD_Update Register

7	6	5	4	3	2	1	0
update_cmd							
W1C-0h							

Table 2-19. CMD_Update Register Field Descriptions

Bit	Field	Type	Reset	Description
7-0	update_cmd	W1C	0h	Configuration update command: registers001h to 00Bh will ONLY be effective by sending this command Write 55h to send this command

2.4.2 CMD_Start Register (Offset = 11h) [Reset = 00h]

CMD_Start is shown in Figure 2-16 and described in Table 2-20.

Return to the [Summary Table](#).

Figure 2-16. CMD_Start Register

7	6	5	4	3	2	1	0
start_cmd							
W1C-0h							

Table 2-20. CMD_Start Register Field Descriptions

Bit	Field	Type	Reset	Description
7-0	start_cmd	W1C	0h	Send start_cmd to start autonomous control or restart with the latest setting Write FFh to send this command

2.4.3 CMD_Stop Register (Offset = 12h) [Reset = 00h]

CMD_Stop is shown in Figure 2-17 and described in Table 2-21.

Return to the [Summary Table](#).

Figure 2-17. CMD_Stop Register

7	6	5	4	3	2	1	0
stop_cmd							
W1C-0h							

Table 2-21. CMD_Stop Register Field Descriptions

Bit	Field	Type	Reset	Description
7-0	stop_cmd	W1C	0h	Stop LED current status immediately, and go back to INITIAL state Write AAh to send this command

2.4.4 CMD_Pause Register (Offset = 13h) [Reset = 00h]

CMD_Pause is shown in [Figure 2-18](#) and described in [Table 2-22](#).

Return to the [Summary Table](#).

Figure 2-18. CMD_Pause Register

7	6	5	4	3	2	1	0
pause_cmd							
W1C-0h							

Table 2-22. CMD_Pause Register Field Descriptions

Bit	Field	Type	Reset	Description
7-0	pause_cmd	W1C	0h	Pause autonomous control at the current state, keep Internal sloper register unchanged, but the scan keeps going-on using the previous calculated pwm data Write 33h to send this command

2.4.5 CMD_Continue Register (Offset = 14h) [Reset = 00h]

CMD_Continue is shown in [Figure 2-19](#) and described in [Table 2-23](#).

Return to the [Summary Table](#).

Figure 2-19. CMD_Continue Register

7	6	5	4	3	2	1	0
continue_cmd							
W1C-0h							

Table 2-23. CMD_Continue Register Field Descriptions

Bit	Field	Type	Reset	Description
7-0	continue_cmd	W1C	0h	Continue autonomous control Write CCh to send this command

2.5 LED_Enable Registers

Table 2-24 lists the memory-mapped registers for the LED_Enable registers. All register offset addresses not listed in Table 2-24 should be considered as reserved locations and the register contents should not be modified.

Table 2-24. LED_ENABLE Registers

Offset	Acronym	Register Name	Section
20h	LED_EN_1	Enable the LEDs of LED_0 to LED_3	Go

2.5.1 LED_EN_1 Register (Offset = 20h) [Reset = 00h]

LED_EN_1 is shown in Figure 2-20 and described in Table 2-25.

Return to the [Summary Table](#).

Figure 2-20. LED_EN_1 Register

7	6	5	4	3	2	1	0
RESERVED				led_en_3	led_en_2	led_en_1	led_en_0
R-0h				R/W-0h	R/W-0h	R/W-0h	R/W-0h

Table 2-25. LED_EN_1 Register Field Descriptions

Bit	Field	Type	Reset	Description
7-4	RESERVED	R	0h	Reserved
3	led_en_3	R/W	0h	LED_3 Enable 0h = Disabled 1h = Enabled
2	led_en_2	R/W	0h	LED_2 Enable 0h = Disabled 1h = Enabled
1	led_en_1	R/W	0h	LED_1 Enable 0h = Disabled 1h = Enabled
0	led_en_0	R/W	0h	LED_0 Enable 0h = Disabled 1h = Enabled

2.6 Fault_Clear Registers

Table 2-26 lists the memory-mapped registers for the Fault_Clear registers. All register offset addresses not listed in Table 2-26 should be considered as reserved locations and the register contents should not be modified.

Table 2-26. FAULT_CLEAR Registers

Offset	Acronym	Register Name	Section
22h	Fault_Clear	Clear the LOD/LSD/TSD flats	Go

2.6.1 Fault_Clear Register (Offset = 22h) [Reset = 00h]

Fault_Clear is shown in Figure 2-21 and described in Table 2-27.

Return to the [Summary Table](#).

Figure 2-21. Fault_Clear Register

7	6	5	4	3	2	1	0
RESERVED					tsd_clear	lsd_clear	lod_clear
R-0h					W1C-0h	W1C-0h	W1C-0h

Table 2-27. Fault_Clear Register Field Descriptions

Bit	Field	Type	Reset	Description
7-3	RESERVED	R	0h	Reserved
2	tsd_clear	W1C	0h	TSD Fault Status Clear Write 1 to clear and read back 0
1	lsd_clear	W1C	0h	LSD Fault Status Clear Write 1 to clear and read back 0
0	lod_clear	W1C	0h	LOD Fault Status Clear Write 1 to clear and read back 0

2.7 Reset Registers

Table 2-28 lists the memory-mapped registers for the Reset registers. All register offset addresses not listed in Table 2-28 should be considered as reserved locations and the register contents should not be modified.

Table 2-28. RESET Registers

Offset	Acronym	Register Name	Section
23h	Reset	Software reset	Go

2.7.1 Reset Register (Offset = 23h) [Reset = 00h]

Reset is shown in Figure 2-22 and described in Table 2-29.

Return to the [Summary Table](#).

Figure 2-22. Reset Register

7	6	5	4	3	2	1	0
sw_reset							
W1C-0h							

Table 2-29. Reset Register Field Descriptions

Bit	Field	Type	Reset	Description
7-0	sw_reset	W1C	0h	Software reset Write 66h to reset

2.8 Manual_DC Registers

Table 2-30 lists the memory-mapped registers for the Manual_DC registers. All register offset addresses not listed in Table 2-30 should be considered as reserved locations and the register contents should not be modified.

Table 2-30. MANUAL_DC Registers

Offset	Acronym	Register Name	Section
30h	Manual_DC_0	LED_0 current setting in manual mode	Go
31h	Manual_DC_1	LED_1 current setting in manual mode	Go
32h	Manual_DC_2	LED_2 current setting in manual mode	Go
33h	Manual_DC_3	LED_3 current setting in manual mode	Go

2.8.1 Manual_DC_0 Register (Offset = 30h) [Reset = 00h]

Manual_DC_0 is shown in Figure 2-23 and described in Table 2-31.

Return to the [Summary Table](#).

Figure 2-23. Manual_DC_0 Register

7	6	5	4	3	2	1	0
manual_dc_0							
R/W-0h							

Table 2-31. Manual_DC_0 Register Field Descriptions

Bit	Field	Type	Reset	Description
7-0	manual_dc_0	R/W	0h	LED_0 current setting in manual mode 0h = 0 1h = 0.39% 2h = 0.78% ... 80h = 50.2% ... FDh = 99.2% FEh = 99.6% FFh = 100%

2.8.2 Manual_DC_1 Register (Offset = 31h) [Reset = 00h]

Manual_DC_1 is shown in Figure 2-24 and described in Table 2-32.

Return to the [Summary Table](#).

Figure 2-24. Manual_DC_1 Register

7	6	5	4	3	2	1	0
manual_dc_1							
R/W-0h							

Table 2-32. Manual_DC_1 Register Field Descriptions

Bit	Field	Type	Reset	Description
7-0	manual_dc_1	R/W	0h	LED_1 current setting in manual mode 0h = 0 1h = 0.39% 2h = 0.78% ... 80h = 50.2% ... FDh = 99.2% FEh = 99.6% FFh = 100%

2.8.3 Manual_DC_2 Register (Offset = 32h) [Reset = 00h]

Manual_DC_2 is shown in [Figure 2-25](#) and described in [Table 2-33](#).

Return to the [Summary Table](#).

Figure 2-25. Manual_DC_2 Register

7	6	5	4	3	2	1	0
manual_dc_2							
R/W-0h							

Table 2-33. Manual_DC_2 Register Field Descriptions

Bit	Field	Type	Reset	Description
7-0	manual_dc_2	R/W	0h	LED_2 current setting in manual mode 0h = 0 1h = 0.39% 2h = 0.78% ... 80h = 50.2% ... FDh = 99.2% FEh = 99.6% FFh = 100%

2.8.4 Manual_DC_3 Register (Offset = 33h) [Reset = 00h]

Manual_DC_3 is shown in [Figure 2-26](#) and described in [Table 2-34](#).

Return to the [Summary Table](#).

Figure 2-26. Manual_DC_3 Register

7	6	5	4	3	2	1	0
manual_dc_3							
R/W-0h							

Table 2-34. Manual_DC_3 Register Field Descriptions

Bit	Field	Type	Reset	Description
7-0	manual_dc_3	R/W	0h	LED_3 current setting in manual mode 0h = 0 1h = 0.39% 2h = 0.78% ... 80h = 50.2% ... FDh = 99.2% FEh = 99.6% FFh = 100%

2.9 Manual_PWM Registers

Table 2-35 lists the memory-mapped registers for the Manual_PWM registers. All register offset addresses not listed in Table 2-35 should be considered as reserved locations and the register contents should not be modified.

Table 2-35. MANUAL_PWM Registers

Offset	Acronym	Register Name	Section
40h	Manual_PWM_0	LED_0 PWM setting in manual mode	Go
41h	Manual_PWM_1	LED_1 PWM setting in manual mode	Go
42h	Manual_PWM_2	LED_2 PWM setting in manual mode	Go
43h	Manual_PWM_3	LED_3 PWM setting in manual mode	Go

2.9.1 Manual_PWM_0 Register (Offset = 40h) [Reset = 00h]

Manual_PWM_0 is shown in Figure 2-27 and described in Table 2-36.

Return to the [Summary Table](#).

Figure 2-27. Manual_PWM_0 Register

7	6	5	4	3	2	1	0
manual_pwm_0							
R/W-0h							

Table 2-36. Manual_PWM_0 Register Field Descriptions

Bit	Field	Type	Reset	Description
7-0	manual_pwm_0	R/W	0h	LED_0 PWM setting in manual mode 0h = 0 1h = 0.39% 2h = 0.78% ... 80h = 50.2% ... FDh = 99.2% FEh = 99.6% FFh = 100%

2.9.2 Manual_PWM_1 Register (Offset = 41h) [Reset = 00h]

Manual_PWM_1 is shown in Figure 2-28 and described in Table 2-37.

Return to the [Summary Table](#).

Figure 2-28. Manual_PWM_1 Register

7	6	5	4	3	2	1	0
manual_pwm_1							
R/W-0h							

Table 2-37. Manual_PWM_1 Register Field Descriptions

Bit	Field	Type	Reset	Description
7-0	manual_pwm_1	R/W	0h	LED_1 PWM setting in manual mode 0h = 0 1h = 0.39% 2h = 0.78% ... 80h = 50.2% ... FDh = 99.2% FEh = 99.6% FFh = 100%

2.9.3 Manual_PWM_2 Register (Offset = 42h) [Reset = 00h]

Manual_PWM_2 is shown in [Figure 2-29](#) and described in [Table 2-38](#).

Return to the [Summary Table](#).

Figure 2-29. Manual_PWM_2 Register

7	6	5	4	3	2	1	0
manual_pwm_2							
R/W-0h							

Table 2-38. Manual_PWM_2 Register Field Descriptions

Bit	Field	Type	Reset	Description
7-0	manual_pwm_2	R/W	0h	LED_2 PWM setting in manual mode 0h = 0 1h = 0.39% 2h = 0.78% ... 80h = 50.2% ... FDh = 99.2% FEh = 99.6% FFh = 100%

2.9.4 Manual_PWM_3 Register (Offset = 43h) [Reset = 00h]

Manual_PWM_3 is shown in [Figure 2-30](#) and described in [Table 2-39](#).

Return to the [Summary Table](#).

Figure 2-30. Manual_PWM_3 Register

7	6	5	4	3	2	1	0
manual_pwm_3							
R/W-0h							

Table 2-39. Manual_PWM_3 Register Field Descriptions

Bit	Field	Type	Reset	Description
7-0	manual_pwm_3	R/W	0h	LED_3 PWM setting in manual mode 0h = 0 1h = 0.39% 2h = 0.78% ... 80h = 50.2% ... FDh = 99.2% FEh = 99.6% FFh = 100%

2.10 Autonomous_DC Registers

Table 2-40 lists the memory-mapped registers for the Autonomous_DC registers. All register offset addresses not listed in Table 2-40 should be considered as reserved locations and the register contents should not be modified.

Table 2-40. AUTONOMOUS_DC Registers

Offset	Acronym	Register Name	Section
50h	Auto_DC_0	LED_0 current setting in autonomous mode	Go
51h	Auto_DC_1	LED_1 current setting in autonomous mode	Go
52h	Auto_DC_2	LED_2 current setting in autonomous mode	Go
53h	Auto_DC_3	LED_3 current setting in autonomous mode	Go

2.10.1 Auto_DC_0 Register (Offset = 50h) [Reset = 00h]

Auto_DC_0 is shown in Figure 2-31 and described in Table 2-41.

Return to the [Summary Table](#).

Figure 2-31. Auto_DC_0 Register

7	6	5	4	3	2	1	0
auto_dc_0							
R/W-0h							

Table 2-41. Auto_DC_0 Register Field Descriptions

Bit	Field	Type	Reset	Description
7-0	auto_dc_0	R/W	0h	LED_0 current setting in autonomous mode 0h = 0 1h = 0.39% 2h = 0.78% ... 80h = 50.2% ... FDh = 99.2% FEh = 99.6% FFh = 100%

2.10.2 Auto_DC_1 Register (Offset = 51h) [Reset = 00h]

Auto_DC_1 is shown in Figure 2-32 and described in Table 2-42.

Return to the [Summary Table](#).

Figure 2-32. Auto_DC_1 Register

7	6	5	4	3	2	1	0
auto_dc_1							
R/W-0h							

Table 2-42. Auto_DC_1 Register Field Descriptions

Bit	Field	Type	Reset	Description
7-0	auto_dc_1	R/W	0h	LED_1 current setting in autonomous mode 0h = 0 1h = 0.39% 2h = 0.78% ... 80h = 50.2% ... FDh = 99.2% FEh = 99.6% FFh = 100%

2.10.3 Auto_DC_2 Register (Offset = 52h) [Reset = 00h]

Auto_DC_2 is shown in [Figure 2-33](#) and described in [Table 2-43](#).

Return to the [Summary Table](#).

Figure 2-33. Auto_DC_2 Register

7	6	5	4	3	2	1	0
auto_dc_2							
R/W-0h							

Table 2-43. Auto_DC_2 Register Field Descriptions

Bit	Field	Type	Reset	Description
7-0	auto_dc_2	R/W	0h	LED_2 current setting in autonomous mode 0h = 0 1h = 0.39% 2h = 0.78% ... 80h = 50.2% ... FDh = 99.2% FEh = 99.6% FFh = 100%

2.10.4 Auto_DC_3 Register (Offset = 53h) [Reset = 00h]

Auto_DC_3 is shown in [Figure 2-34](#) and described in [Table 2-44](#).

Return to the [Summary Table](#).

Figure 2-34. Auto_DC_3 Register

7	6	5	4	3	2	1	0
auto_dc_3							
R/W-0h							

Table 2-44. Auto_DC_3 Register Field Descriptions

Bit	Field	Type	Reset	Description
7-0	auto_dc_3	R/W	0h	LED_3 current setting in autonomous mode 0h = 0 1h = 0.39% 2h = 0.78% ... 80h = 50.2% ... FDh = 99.2% FEh = 99.6% FFh = 100%

2.11 LED_0_Autonomous_Animation Registers

Table 2-45 lists the memory-mapped registers for the LED_0_Autonomous_Animation registers. All register offset addresses not listed in Table 2-45 should be considered as reserved locations and the register contents should not be modified.

Table 2-45. LED_0_AUTONOMOUS_ANIMATION Registers

Offset	Acronym	Register Name	Section
80h	LED_0_Auto_Pause	Animation pause time at the start and the end of LED_0	Go
81h	LED_0_Auto_Playback	Animation pattern playback times of LED_0 and active AEU number setting	Go
82h	LED_0_AEU1_PWM_1	PWM setting of LED_0 AEU1_PWM1	Go
83h	LED_0_AEU1_PWM_2	PWM setting of LED_0 AEU1_PWM2	Go
84h	LED_0_AEU1_PWM_3	PWM setting of LED_0 AEU1_PWM3	Go
85h	LED_0_AEU1_PWM_4	PWM setting of LED_0 AEU1_PWM4	Go
86h	LED_0_AEU1_PWM_5	PWM setting of LED_0 AEU1_PWM5	Go
87h	LED_0_AEU1_T12	Slope time setting of LED_0 AEU1_T1 and AEU1_T2	Go
88h	LED_0_AEU1_T34	Slope time setting of LED_0 AEU1_T3 and AEU1_T4	Go
89h	LED_0_AEU1_Playback	AEU1 pattern playback times of LED_0	Go
8Ah	LED_0_AEU2_PWM_1	PWM setting of LED_0 AEU2_PWM1	Go
8Bh	LED_0_AEU2_PWM_2	PWM setting of LED_0 AEU2_PWM2	Go
8Ch	LED_0_AEU2_PWM_3	PWM setting of LED_0 AEU2_PWM3	Go
8Dh	LED_0_AEU2_PWM_4	PWM setting of LED_0 AEU2_PWM4	Go
8Eh	LED_0_AEU2_PWM_5	PWM setting of LED_0 AEU2_PWM5	Go
8Fh	LED_0_AEU2_T12	Slope time setting of LED_0 AEU2_T1 and AEU2_T2	Go
90h	LED_0_AEU2_T34	Slope time setting of LED_0 AEU2_T3 and AEU2_T4	Go
91h	LED_0_AEU2_Playback	AEU2 pattern playback times of LED_0	Go
92h	LED_0_AEU3_PWM_1	PWM setting of LED_0 AEU3_PWM1	Go
93h	LED_0_AEU3_PWM_2	PWM setting of LED_0 AEU3_PWM2	Go
94h	LED_0_AEU3_PWM_3	PWM setting of LED_0 AEU3_PWM3	Go
95h	LED_0_AEU3_PWM_4	PWM setting of LED_0 AEU3_PWM4	Go
96h	LED_0_AEU3_PWM_5	PWM setting of LED_0 AEU3_PWM5	Go
97h	LED_0_AEU3_T12	Slope time setting of LED_0 AEU3_T1 and AEU3_T2	Go
98h	LED_0_AEU3_T34	Slope time setting of LED_0 AEU3_T3 and AEU3_T4	Go
99h	LED_0_AEU3_Playback	AEU3 pattern playback times of LED_0	Go

2.11.1 LED_0_Auto_Pause Register (Offset = 80h) [Reset = 00h]

LED_0_Auto_Pause is shown in Figure 2-35 and described in Table 2-46.

Return to the [Summary Table](#).

Figure 2-35. LED_0_Auto_Pause Register

7	6	5	4	3	2	1	0
led_0_tp_ts				led_0_tp_te			
R/W-0h				R/W-0h			

Table 2-46. LED_0_Auto_Pause Register Field Descriptions

Bit	Field	Type	Reset	Description
7-4	led_0_tp_ts	R/W	0h	Animation pause time at the start of LED_0 0h = no pause time 1h = 0.09s 2h = 0.18s 3h = 0.36s 4h = 0.54s 5h = 0.80s 6h = 1.07s 7h = 1.52s 8h = 2.06s 9h = 2.50s Ah = 3.04s Bh = 4.02s Ch = 5.01s Dh = 5.99s Eh = 7.06s Fh = 8.05s
3-0	led_0_tp_te	R/W	0h	Animation pause time at the end of LED_0 0h = no pause time 1h = 0.09s 2h = 0.18s 3h = 0.36s 4h = 0.54s 5h = 0.80s 6h = 1.07s 7h = 1.52s 8h = 2.06s 9h = 2.50s Ah = 3.04s Bh = 4.02s Ch = 5.01s Dh = 5.99s Eh = 7.06s Fh = 8.05s

2.11.2 LED_0_Auto_Playback Register (Offset = 81h) [Reset = 00h]

LED_0_Auto_Playback is shown in [Figure 2-36](#) and described in [Table 2-47](#).

Return to the [Summary Table](#).

Figure 2-36. LED_0_Auto_Playback Register

7	6	5	4	3	2	1	0
RESERVED		led_0_aeu_num		led_0_pt			
R-0h		R/W-0h		R/W-0h			

Table 2-47. LED_0_Auto_Playback Register Field Descriptions

Bit	Field	Type	Reset	Description
7-6	RESERVED	R	0h	Reserved
5-4	led_0_aeu_num	R/W	0h	Active AEU number of LED_0 selection 0h = only use AEU1 1h = use AEU1 and AEU2 2h = use AEU1, AEU2 and AEU3 3h = use AEU1, AEU2 and AEU3 (the same as 2h)

Table 2-47. LED_0_Auto_Playback Register Field Descriptions (continued)

Bit	Field	Type	Reset	Description
3-0	led_0_pt	R/W	0h	Animation pattern playback times of LED_0 0h = 0 times 1h = 1 times 2h = 2 times 3h = 3 times 4h = 4 times 5h = 5 times 6h = 6 times 7h = 7 times 8h = 8 times 9h = 9 times Ah = 10 times Bh = 11 times Ch = 12 times Dh = 13 times Eh = 14 times Fh = infinite times

2.11.3 LED_0_AEU1_PWM_1 Register (Offset = 82h) [Reset = 00h]

LED_0_AEU1_PWM_1 is shown in [Figure 2-37](#) and described in [Table 2-48](#).

Return to the [Summary Table](#).

Figure 2-37. LED_0_AEU1_PWM_1 Register

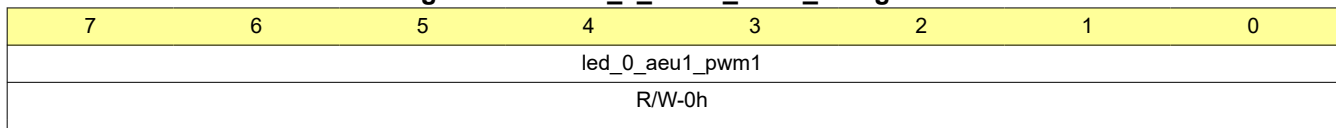

Table 2-48. LED_0_AEU1_PWM_1 Register Field Descriptions

Bit	Field	Type	Reset	Description
7-0	led_0_aeu1_pwm1	R/W	0h	AEU1_PWM1 setting of LED_0 0h = 0 1h = 0.39% 2h = 0.78% ... 80h = 50.2% ... FDh = 99.2% FEh = 99.6% FFh = 100%

2.11.4 LED_0_AEU1_PWM_2 Register (Offset = 83h) [Reset = 00h]

LED_0_AEU1_PWM_2 is shown in [Figure 2-38](#) and described in [Table 2-49](#).

Return to the [Summary Table](#).

Figure 2-38. LED_0_AEU1_PWM_2 Register

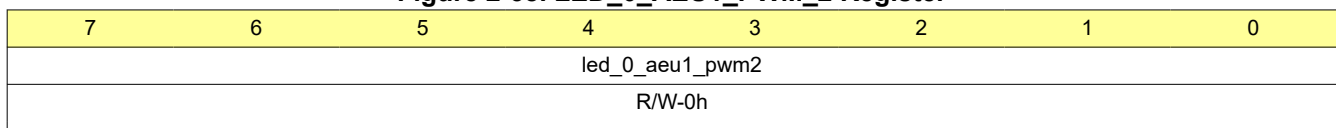

Table 2-49. LED_0_AEU1_PWM_2 Register Field Descriptions

Bit	Field	Type	Reset	Description
7-0	led_0_aeu1_pwm2	R/W	0h	AEU1_PWM2 setting of LED_0 0h = 0 1h = 0.39% 2h = 0.78% ... 80h = 50.2% ... FDh = 99.2% FEh = 99.6% FFh = 100%

2.11.5 LED_0_AEU1_PWM_3 Register (Offset = 84h) [Reset = 00h]

LED_0_AEU1_PWM_3 is shown in [Figure 2-39](#) and described in [Table 2-50](#).

Return to the [Summary Table](#).

Figure 2-39. LED_0_AEU1_PWM_3 Register

7	6	5	4	3	2	1	0
led_0_aeu1_pwm3							
R/W-0h							

Table 2-50. LED_0_AEU1_PWM_3 Register Field Descriptions

Bit	Field	Type	Reset	Description
7-0	led_0_aeu1_pwm3	R/W	0h	AEU1_PWM3 setting of LED_0 0h = 0 1h = 0.39% 2h = 0.78% ... 80h = 50.2% ... FDh = 99.2% FEh = 99.6% FFh = 100%

2.11.6 LED_0_AEU1_PWM_4 Register (Offset = 85h) [Reset = 00h]

LED_0_AEU1_PWM_4 is shown in [Figure 2-40](#) and described in [Table 2-51](#).

Return to the [Summary Table](#).

Figure 2-40. LED_0_AEU1_PWM_4 Register

7	6	5	4	3	2	1	0
led_0_aeu1_pwm4							
R/W-0h							

Table 2-51. LED_0_AEU1_PWM_4 Register Field Descriptions

Bit	Field	Type	Reset	Description
7-0	led_0_aeu1_pwm4	R/W	0h	AEU1_PWM4 setting of LED_0 0h = 0 1h = 0.39% 2h = 0.78% ... 80h = 50.2% ... FDh = 99.2% FEh = 99.6% FFh = 100%

2.11.7 LED_0_AEU1_PWM_5 Register (Offset = 86h) [Reset = 00h]

LED_0_AEU1_PWM_5 is shown in [Figure 2-41](#) and described in [Table 2-52](#).

Return to the [Summary Table](#).

Figure 2-41. LED_0_AEU1_PWM_5 Register

7	6	5	4	3	2	1	0
led_0_aeu1_pwm5							
R/W-0h							

Table 2-52. LED_0_AEU1_PWM_5 Register Field Descriptions

Bit	Field	Type	Reset	Description
7-0	led_0_aeu1_pwm5	R/W	0h	AEU1_PWM5 setting of LED_0 0h = 0 1h = 0.39% 2h = 0.78% ... 80h = 50.2% ... FDh = 99.2% FEh = 99.6% FFh = 100%

2.11.8 LED_0_AEU1_T12 Register (Offset = 87h) [Reset = 00h]

LED_0_AEU1_T12 is shown in [Figure 2-42](#) and described in [Table 2-53](#).

Return to the [Summary Table](#).

Figure 2-42. LED_0_AEU1_T12 Register

7	6	5	4	3	2	1	0
led_0_aeu1_t2				led_0_aeu1_t1			
R/W-0h				R/W-0h			

Table 2-53. LED_0_AEU1_T12 Register Field Descriptions

Bit	Field	Type	Reset	Description
7-4	led_0_aeu1_t2	R/W	0h	AEU1_T2 slope time setting of LED_0 0h = no pause time 1h = 0.09s 2h = 0.18s 3h = 0.36s 4h = 0.54s 5h = 0.80s 6h = 1.07s 7h = 1.52s 8h = 2.06s 9h = 2.50s Ah = 3.04s Bh = 4.02s Ch = 5.01s Dh = 5.99s Eh = 7.06s Fh = 8.05s
3-0	led_0_aeu1_t1	R/W	0h	AEU1_T1 slope time setting of LED_0 0h = no pause time 1h = 0.09s 2h = 0.18s 3h = 0.36s 4h = 0.54s 5h = 0.80s 6h = 1.07s 7h = 1.52s 8h = 2.06s 9h = 2.50s Ah = 3.04s Bh = 4.02s Ch = 5.01s Dh = 5.99s Eh = 7.06s Fh = 8.05s

2.11.9 LED_0_AEU1_T34 Register (Offset = 88h) [Reset = 00h]

LED_0_AEU1_T34 is shown in [Figure 2-43](#) and described in [Table 2-54](#).

Return to the [Summary Table](#).

Figure 2-43. LED_0_AEU1_T34 Register

7	6	5	4	3	2	1	0
led_0_aeu1_t4				led_0_aeu1_t3			
R/W-0h				R/W-0h			

Table 2-54. LED_0_AEU1_T34 Register Field Descriptions

Bit	Field	Type	Reset	Description
7-4	led_0_aeu1_t4	R/W	0h	AEU1_T4 slope time setting of LED_0 0h = no pause time 1h = 0.09s 2h = 0.18s 3h = 0.36s 4h = 0.54s 5h = 0.80s 6h = 1.07s 7h = 1.52s 8h = 2.06s 9h = 2.50s Ah = 3.04s Bh = 4.02s Ch = 5.01s Dh = 5.99s Eh = 7.06s Fh = 8.05s
3-0	led_0_aeu1_t3	R/W	0h	AEU1_T3 slope time setting of LED_0 0h = no pause time 1h = 0.09s 2h = 0.18s 3h = 0.36s 4h = 0.54s 5h = 0.80s 6h = 1.07s 7h = 1.52s 8h = 2.06s 9h = 2.50s Ah = 3.04s Bh = 4.02s Ch = 5.01s Dh = 5.99s Eh = 7.06s Fh = 8.05s

2.11.10 LED_0_AEU1_Playback Register (Offset = 89h) [Reset = 00h]

LED_0_AEU1_Playback is shown in [Figure 2-44](#) and described in [Table 2-55](#).

Return to the [Summary Table](#).

Figure 2-44. LED_0_AEU1_Playback Register

7	6	5	4	3	2	1	0
RESERVED						led_0_aeu1_pt	
R-0h						R/W-0h	

Table 2-55. LED_0_AEU1_Playback Register Field Descriptions

Bit	Field	Type	Reset	Description
7-2	RESERVED	R	0h	Reserved
1-0	led_0_aeu1_pt	R/W	0h	AEU1 pattern playback times of LED_0 0h = 0 time 1h = 1 time 2h = 2 times 3h = Infinite times

2.11.11 LED_0_AEU2_PWM_1 Register (Offset = 8Ah) [Reset = 00h]

LED_0_AEU2_PWM_1 is shown in [Figure 2-45](#) and described in [Table 2-56](#).

Return to the [Summary Table](#).

Figure 2-45. LED_0_AEU2_PWM_1 Register

7	6	5	4	3	2	1	0
led_0_aeu2_pwm1							
R/W-0h							

Table 2-56. LED_0_AEU2_PWM_1 Register Field Descriptions

Bit	Field	Type	Reset	Description
7-0	led_0_aeu2_pwm1	R/W	0h	AEU2_PWM1 setting of LED_0 0h = 0 1h = 0.39% 2h = 0.78% ... 80h = 50.2% ... FDh = 99.2% FEh = 99.6% FFh = 100%

2.11.12 LED_0_AEU2_PWM_2 Register (Offset = 8Bh) [Reset = 00h]

LED_0_AEU2_PWM_2 is shown in [Figure 2-46](#) and described in [Table 2-57](#).

Return to the [Summary Table](#).

Figure 2-46. LED_0_AEU2_PWM_2 Register

7	6	5	4	3	2	1	0
led_0_aeu2_pwm2							
R/W-0h							

Table 2-57. LED_0_AEU2_PWM_2 Register Field Descriptions

Bit	Field	Type	Reset	Description
7-0	led_0_aeu2_pwm2	R/W	0h	AEU2_PWM2 setting of LED_0 0h = 0 1h = 0.39% 2h = 0.78% ... 80h = 50.2% ... FDh = 99.2% FEh = 99.6% FFh = 100%

2.11.13 LED_0_AEU2_PWM_3 Register (Offset = 8Ch) [Reset = 00h]

LED_0_AEU2_PWM_3 is shown in [Figure 2-47](#) and described in [Table 2-58](#).

Return to the [Summary Table](#).

Figure 2-47. LED_0_AEU2_PWM_3 Register

7	6	5	4	3	2	1	0
led_0_aeu2_pwm3							
R/W-0h							

Table 2-58. LED_0_AEU2_PWM_3 Register Field Descriptions

Bit	Field	Type	Reset	Description
7-0	led_0_aeu2_pwm3	R/W	0h	AEU2_PWM3 setting of LED_0 0h = 0 1h = 0.39% 2h = 0.78% ... 80h = 50.2% ... FDh = 99.2% FEh = 99.6% FFh = 100%

2.11.14 LED_0_AEU2_PWM_4 Register (Offset = 8Dh) [Reset = 00h]

LED_0_AEU2_PWM_4 is shown in [Figure 2-48](#) and described in [Table 2-59](#).

Return to the [Summary Table](#).

Figure 2-48. LED_0_AEU2_PWM_4 Register

7	6	5	4	3	2	1	0
led_0_aeu2_pwm4							
R/W-0h							

Table 2-59. LED_0_AEU2_PWM_4 Register Field Descriptions

Bit	Field	Type	Reset	Description
7-0	led_0_aeu2_pwm4	R/W	0h	AEU2_PWM4 setting of LED_0 0h = 0 1h = 0.39% 2h = 0.78% ... 80h = 50.2% ... FDh = 99.2% FEh = 99.6% FFh = 100%

2.11.15 LED_0_AEU2_PWM_5 Register (Offset = 8Eh) [Reset = 00h]

LED_0_AEU2_PWM_5 is shown in [Figure 2-49](#) and described in [Table 2-60](#).

Return to the [Summary Table](#).

Figure 2-49. LED_0_AEU2_PWM_5 Register

7	6	5	4	3	2	1	0
led_0_aeu2_pwm5							
R/W-0h							

Table 2-60. LED_0_AEU2_PWM_5 Register Field Descriptions

Bit	Field	Type	Reset	Description
7-0	led_0_aeu2_pwm5	R/W	0h	AEU2_PWM5 setting of LED_0 0h = 0 1h = 0.39% 2h = 0.78% ... 80h = 50.2% ... FDh = 99.2% FEh = 99.6% FFh = 100%

2.11.16 LED_0_AEU2_T12 Register (Offset = 8Fh) [Reset = 00h]

 LED_0_AEU2_T12 is shown in [Figure 2-50](#) and described in [Table 2-61](#).

 Return to the [Summary Table](#).

Figure 2-50. LED_0_AEU2_T12 Register

7	6	5	4	3	2	1	0
led_0_aeu2_t2				led_0_aeu2_t1			
R/W-0h				R/W-0h			

Table 2-61. LED_0_AEU2_T12 Register Field Descriptions

Bit	Field	Type	Reset	Description
7-4	led_0_aeu2_t2	R/W	0h	AEU2_T2 slope time setting of LED_0 0h = no pause time 1h = 0.09s 2h = 0.18s 3h = 0.36s 4h = 0.54s 5h = 0.80s 6h = 1.07s 7h = 1.52s 8h = 2.06s 9h = 2.50s Ah = 3.04s Bh = 4.02s Ch = 5.01s Dh = 5.99s Eh = 7.06s Fh = 8.05s
3-0	led_0_aeu2_t1	R/W	0h	AEU2_T1 slope time setting of LED_0 0h = no pause time 1h = 0.09s 2h = 0.18s 3h = 0.36s 4h = 0.54s 5h = 0.80s 6h = 1.07s 7h = 1.52s 8h = 2.06s 9h = 2.50s Ah = 3.04s Bh = 4.02s Ch = 5.01s Dh = 5.99s Eh = 7.06s Fh = 8.05s

2.11.17 LED_0_AEU2_T34 Register (Offset = 90h) [Reset = 00h]

LED_0_AEU2_T34 is shown in [Figure 2-51](#) and described in [Table 2-62](#).

Return to the [Summary Table](#).

Figure 2-51. LED_0_AEU2_T34 Register

7	6	5	4	3	2	1	0
led_0_aeu2_t4				led_0_aeu2_t3			
R/W-0h				R/W-0h			

Table 2-62. LED_0_AEU2_T34 Register Field Descriptions

Bit	Field	Type	Reset	Description
7-4	led_0_aeu2_t4	R/W	0h	AEU2_T4 slope time setting of LED_0 0h = no pause time 1h = 0.09s 2h = 0.18s 3h = 0.36s 4h = 0.54s 5h = 0.80s 6h = 1.07s 7h = 1.52s 8h = 2.06s 9h = 2.50s Ah = 3.04s Bh = 4.02s Ch = 5.01s Dh = 5.99s Eh = 7.06s Fh = 8.05s
3-0	led_0_aeu2_t3	R/W	0h	AEU2_T3 slope time setting of LED_0 0h = no pause time 1h = 0.09s 2h = 0.18s 3h = 0.36s 4h = 0.54s 5h = 0.80s 6h = 1.07s 7h = 1.52s 8h = 2.06s 9h = 2.50s Ah = 3.04s Bh = 4.02s Ch = 5.01s Dh = 5.99s Eh = 7.06s Fh = 8.05s

2.11.18 LED_0_AEU2_Playback Register (Offset = 91h) [Reset = 00h]

LED_0_AEU2_Playback is shown in [Figure 2-52](#) and described in [Table 2-63](#).

Return to the [Summary Table](#).

Figure 2-52. LED_0_AEU2_Playback Register

7	6	5	4	3	2	1	0
RESERVED						led_0_aeu2_pt	
R-0h						R/W-0h	

Table 2-63. LED_0_AEU2_Playback Register Field Descriptions

Bit	Field	Type	Reset	Description
7-2	RESERVED	R	0h	Reserved
1-0	led_0_aeu2_pt	R/W	0h	AEU2 pattern playback times of LED_0 0h = 0 time 1h = 1 time 2h = 2 times 3h = Infinite times

2.11.19 LED_0_AEU3_PWM_1 Register (Offset = 92h) [Reset = 00h]

LED_0_AEU3_PWM_1 is shown in [Figure 2-53](#) and described in [Table 2-64](#).

Return to the [Summary Table](#).

Figure 2-53. LED_0_AEU3_PWM_1 Register

7	6	5	4	3	2	1	0
led_0_aeu3_pwm1							
R/W-0h							

Table 2-64. LED_0_AEU3_PWM_1 Register Field Descriptions

Bit	Field	Type	Reset	Description
7-0	led_0_aeu3_pwm1	R/W	0h	AEU3_PWM1 setting of LED_0 0h = 0 1h = 0.39% 2h = 0.78% ... 80h = 50.2% ... FDh = 99.2% FEh = 99.6% FFh = 100%

2.11.20 LED_0_AEU3_PWM_2 Register (Offset = 93h) [Reset = 00h]

LED_0_AEU3_PWM_2 is shown in [Figure 2-54](#) and described in [Table 2-65](#).

Return to the [Summary Table](#).

Figure 2-54. LED_0_AEU3_PWM_2 Register

7	6	5	4	3	2	1	0
led_0_aeu3_pwm2							
R/W-0h							

Table 2-65. LED_0_AEU3_PWM_2 Register Field Descriptions

Bit	Field	Type	Reset	Description
7-0	led_0_aeu3_pwm2	R/W	0h	AEU3_PWM2 setting of LED_0 0h = 0 1h = 0.39% 2h = 0.78% ... 80h = 50.2% ... FDh = 99.2% FEh = 99.6% FFh = 100%

2.11.21 LED_0_AEU3_PWM_3 Register (Offset = 94h) [Reset = 00h]

LED_0_AEU3_PWM_3 is shown in [Figure 2-55](#) and described in [Table 2-66](#).

Return to the [Summary Table](#).

Figure 2-55. LED_0_AEU3_PWM_3 Register

7	6	5	4	3	2	1	0
led_0_aeu3_pwm3							
R/W-0h							

Table 2-66. LED_0_AEU3_PWM_3 Register Field Descriptions

Bit	Field	Type	Reset	Description
7-0	led_0_aeu3_pwm3	R/W	0h	AEU3_PWM3 setting of LED_0 0h = 0 1h = 0.39% 2h = 0.78% ... 80h = 50.2% ... FDh = 99.2% FEh = 99.6% FFh = 100%

2.11.22 LED_0_AEU3_PWM_4 Register (Offset = 95h) [Reset = 00h]

LED_0_AEU3_PWM_4 is shown in [Figure 2-56](#) and described in [Table 2-67](#).

Return to the [Summary Table](#).

Figure 2-56. LED_0_AEU3_PWM_4 Register

7	6	5	4	3	2	1	0
led_0_aeu3_pwm4							
R/W-0h							

Table 2-67. LED_0_AEU3_PWM_4 Register Field Descriptions

Bit	Field	Type	Reset	Description
7-0	led_0_aeu3_pwm4	R/W	0h	AEU3_PWM4 setting of LED_0 0h = 0 1h = 0.39% 2h = 0.78% ... 80h = 50.2% ... FDh = 99.2% FEh = 99.6% FFh = 100%

2.11.23 LED_0_AEU3_PWM_5 Register (Offset = 96h) [Reset = 00h]

LED_0_AEU3_PWM_5 is shown in [Figure 2-57](#) and described in [Table 2-68](#).

Return to the [Summary Table](#).

Figure 2-57. LED_0_AEU3_PWM_5 Register

7	6	5	4	3	2	1	0
led_0_aeu3_pwm5							
R/W-0h							

Figure 2-57. LED_0_AEU3_PWM_5 Register (continued)
Table 2-68. LED_0_AEU3_PWM_5 Register Field Descriptions

Bit	Field	Type	Reset	Description
7-0	led_0_aeu3_pwm5	R/W	0h	AEU3_PWM5 setting of LED_0 0h = 0 1h = 0.39% 2h = 0.78% ... 80h = 50.2% ... FDh = 99.2% FEh = 99.6% FFh = 100%

2.11.24 LED_0_AEU3_T12 Register (Offset = 97h) [Reset = 00h]

LED_0_AEU3_T12 is shown in [Figure 2-58](#) and described in [Table 2-69](#).

Return to the [Summary Table](#).

Figure 2-58. LED_0_AEU3_T12 Register

7	6	5	4	3	2	1	0
led_0_aeu3_t2				led_0_aeu3_t1			
R/W-0h				R/W-0h			

Table 2-69. LED_0_AEU3_T12 Register Field Descriptions

Bit	Field	Type	Reset	Description
7-4	led_0_aeu3_t2	R/W	0h	AEU3_T2 slope time setting of LED_0 0h = no pause time 1h = 0.09s 2h = 0.18s 3h = 0.36s 4h = 0.54s 5h = 0.80s 6h = 1.07s 7h = 1.52s 8h = 2.06s 9h = 2.50s Ah = 3.04s Bh = 4.02s Ch = 5.01s Dh = 5.99s Eh = 7.06s Fh = 8.05s

Table 2-69. LED_0_AEU3_T12 Register Field Descriptions (continued)

Bit	Field	Type	Reset	Description
3-0	led_0_aeu3_t1	R/W	0h	AEU3_T1 slope time setting of LED_0 0h = no pause time 1h = 0.09s 2h = 0.18s 3h = 0.36s 4h = 0.54s 5h = 0.80s 6h = 1.07s 7h = 1.52s 8h = 2.06s 9h = 2.50s Ah = 3.04s Bh = 4.02s Ch = 5.01s Dh = 5.99s Eh = 7.06s Fh = 8.05s

2.11.25 LED_0_AEU3_T34 Register (Offset = 98h) [Reset = 00h]

LED_0_AEU3_T34 is shown in [Figure 2-59](#) and described in [Table 2-70](#).

Return to the [Summary Table](#).

Figure 2-59. LED_0_AEU3_T34 Register

7	6	5	4	3	2	1	0
led_0_aeu3_t4				led_0_aeu3_t3			
R/W-0h				R/W-0h			

Table 2-70. LED_0_AEU3_T34 Register Field Descriptions

Bit	Field	Type	Reset	Description
7-4	led_0_aeu3_t4	R/W	0h	AEU3_T4 slope time setting of LED_0 0h = no pause time 1h = 0.09s 2h = 0.18s 3h = 0.36s 4h = 0.54s 5h = 0.80s 6h = 1.07s 7h = 1.52s 8h = 2.06s 9h = 2.50s Ah = 3.04s Bh = 4.02s Ch = 5.01s Dh = 5.99s Eh = 7.06s Fh = 8.05s

Table 2-70. LED_0_AEU3_T34 Register Field Descriptions (continued)

Bit	Field	Type	Reset	Description
3-0	led_0_aeu3_t3	R/W	0h	AEU3_T3 slope time setting of LED_0 0h = no pause time 1h = 0.09s 2h = 0.18s 3h = 0.36s 4h = 0.54s 5h = 0.80s 6h = 1.07s 7h = 1.52s 8h = 2.06s 9h = 2.50s Ah = 3.04s Bh = 4.02s Ch = 5.01s Dh = 5.99s Eh = 7.06s Fh = 8.05s

2.11.26 LED_0_AEU3_Playback Register (Offset = 99h) [Reset = 00h]

LED_0_AEU3_Playback is shown in [Figure 2-60](#) and described in [Table 2-71](#).

Return to the [Summary Table](#).

Figure 2-60. LED_0_AEU3_Playback Register

7	6	5	4	3	2	1	0
RESERVED						led_0_aeu3_pt	
R-0h						R/W-0h	

Table 2-71. LED_0_AEU3_Playback Register Field Descriptions

Bit	Field	Type	Reset	Description
7-2	RESERVED	R	0h	Reserved
1-0	led_0_aeu3_pt	R/W	0h	AEU3 pattern playback times of LED_0 0h = 0 time 1h = 1 time 2h = 2 times 3h = Infinite times

2.12 LED_1_Autonomous_Animation Registers

Table 2-72 lists the memory-mapped registers for the LED_1_Autonomous_Animation registers. All register offset addresses not listed in Table 2-72 should be considered as reserved locations and the register contents should not be modified.

Table 2-72. LED_1_AUTONOMOUS_ANIMATION Registers

Offset	Acronym	Register Name	Section
9Ah	LED_1_Auto_Pause	Animation pause time at the start and the end of LED_1	Go
9Bh	LED_1_Auto_Playback	Animation pattern playback times of LED_1 and active AEU number setting	Go
9Ch	LED_1_AEU1_PWM_1	PWM setting of LED_1 AEU1_PWM1	Go
9Dh	LED_1_AEU1_PWM_2	PWM setting of LED_1 AEU1_PWM2	Go
9Eh	LED_1_AEU1_PWM_3	PWM setting of LED_1 AEU1_PWM3	Go
9Fh	LED_1_AEU1_PWM_4	PWM setting of LED_1 AEU1_PWM4	Go
A0h	LED_1_AEU1_PWM_5	PWM setting of LED_1 AEU1_PWM5	Go
A1h	LED_1_AEU1_T12	Slope time setting of LED_1 AEU1_T1 and AEU1_T2	Go
A2h	LED_1_AEU1_T34	Slope time setting of LED_1 AEU1_T3 and AEU1_T4	Go
A3h	LED_1_AEU1_Playback	AEU1 pattern playback times of LED_1	Go
A4h	LED_1_AEU2_PWM_1	PWM setting of LED_1 AEU2_PWM1	Go
A5h	LED_1_AEU2_PWM_2	PWM setting of LED_1 AEU2_PWM2	Go
A6h	LED_1_AEU2_PWM_3	PWM setting of LED_1 AEU2_PWM3	Go
A7h	LED_1_AEU2_PWM_4	PWM setting of LED_1 AEU2_PWM4	Go
A8h	LED_1_AEU2_PWM_5	PWM setting of LED_1 AEU2_PWM5	Go
A9h	LED_1_AEU2_T12	Slope time setting of LED_1 AEU2_T1 and AEU2_T2	Go
AAh	LED_1_AEU2_T34	Slope time setting of LED_1 AEU2_T3 and AEU2_T4	Go
ABh	LED_1_AEU2_Playback	AEU2 pattern playback times of LED_1	Go
ACH	LED_1_AEU3_PWM_1	PWM setting of LED_1 AEU3_PWM1	Go
ADh	LED_1_AEU3_PWM_2	PWM setting of LED_1 AEU3_PWM2	Go
Aeh	LED_1_AEU3_PWM_3	PWM setting of LED_1 AEU3_PWM3	Go
Afh	LED_1_AEU3_PWM_4	PWM setting of LED_1 AEU3_PWM4	Go
B0h	LED_1_AEU3_PWM_5	PWM setting of LED_1 AEU3_PWM5	Go
B1h	LED_1_AEU3_T12	Slope time setting of LED_1 AEU3_T1 and AEU3_T2	Go
B2h	LED_1_AEU3_T34	Slope time setting of LED_1 AEU3_T3 and AEU3_T4	Go
B3h	LED_1_AEU3_Playback	AEU3 pattern playback times of LED_1	Go

2.12.1 LED_1_Auto_Pause Register (Offset = 9Ah) [Reset = 00h]

LED_1_Auto_Pause is shown in Figure 2-61 and described in Table 2-73.

Return to the [Summary Table](#).

Figure 2-61. LED_1_Auto_Pause Register

7	6	5	4	3	2	1	0
led_1_tp_ts				led_1_tp_te			
R/W-0h				R/W-0h			

Table 2-73. LED_1_Auto_Pause Register Field Descriptions

Bit	Field	Type	Reset	Description
7-4	led_1_tp_ts	R/W	0h	Animation pause time at the start of LED_1 0h = no pause time 1h = 0.09s 2h = 0.18s 3h = 0.36s 4h = 0.54s 5h = 0.80s 6h = 1.07s 7h = 1.52s 8h = 2.06s 9h = 2.50s Ah = 3.04s Bh = 4.02s Ch = 5.01s Dh = 5.99s Eh = 7.06s Fh = 8.05s
3-0	led_1_tp_te	R/W	0h	Animation pause time at the end of LED_1 0h = no pause time 1h = 0.09s 2h = 0.18s 3h = 0.36s 4h = 0.54s 5h = 0.80s 6h = 1.07s 7h = 1.52s 8h = 2.06s 9h = 2.50s Ah = 3.04s Bh = 4.02s Ch = 5.01s Dh = 5.99s Eh = 7.06s Fh = 8.05s

2.12.2 LED_1_Auto_Playback Register (Offset = 9Bh) [Reset = 00h]

LED_1_Auto_Playback is shown in [Figure 2-62](#) and described in [Table 2-74](#).

Return to the [Summary Table](#).

Figure 2-62. LED_1_Auto_Playback Register

7	6	5	4	3	2	1	0
RESERVED		led_1_aeu_num		led_1_pt			
R-0h		R/W-0h		R/W-0h			

Table 2-74. LED_1_Auto_Playback Register Field Descriptions

Bit	Field	Type	Reset	Description
7-6	RESERVED	R	0h	Reserved
5-4	led_1_aeu_num	R/W	0h	Active AEU number of LED_1 selection 0h = only use AEU1 1h = use AEU1 and AEU2 2h = use AEU1, AEU2 and AEU3 3h = use AEU1, AEU2 and AEU3 (the same as 2h)

Table 2-74. LED_1_Auto_Playback Register Field Descriptions (continued)

Bit	Field	Type	Reset	Description
3-0	led_1_pt	R/W	0h	Animation pattern playback times of LED_1 0h = 0 times 1h = 1 times 2h = 2 times 3h = 3 times 4h = 4 times 5h = 5 times 6h = 6 times 7h = 7 times 8h = 8 times 9h = 9 times Ah = 10 times Bh = 11 times Ch = 12 times Dh = 13 times Eh = 14 times Fh = infinite times

2.12.3 LED_1_AEU1_PWM_1 Register (Offset = 9Ch) [Reset = 00h]

LED_1_AEU1_PWM_1 is shown in [Figure 2-63](#) and described in [Table 2-75](#).

Return to the [Summary Table](#).

Figure 2-63. LED_1_AEU1_PWM_1 Register

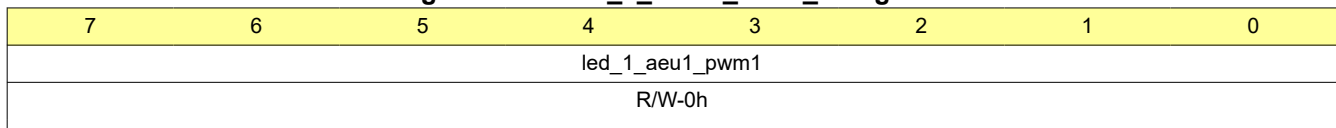

Table 2-75. LED_1_AEU1_PWM_1 Register Field Descriptions

Bit	Field	Type	Reset	Description
7-0	led_1_aeu1_pwm1	R/W	0h	AEU1_PWM1 setting of LED_1 0h = 0 1h = 0.39% 2h = 0.78% ... 80h = 50.2% ... FDh = 99.2% FEh = 99.6% FFh = 100%

2.12.4 LED_1_AEU1_PWM_2 Register (Offset = 9Dh) [Reset = 00h]

LED_1_AEU1_PWM_2 is shown in [Figure 2-64](#) and described in [Table 2-76](#).

Return to the [Summary Table](#).

Figure 2-64. LED_1_AEU1_PWM_2 Register

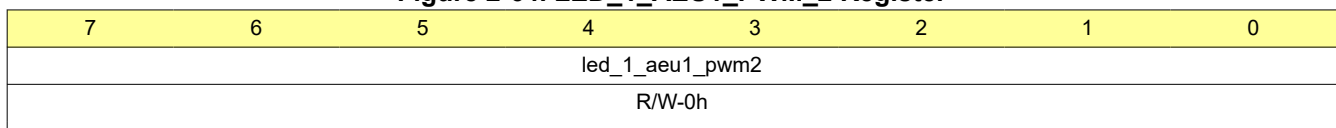

Table 2-76. LED_1_AEU1_PWM_2 Register Field Descriptions

Bit	Field	Type	Reset	Description
7-0	led_1_aeu1_pwm2	R/W	0h	AEU1_PWM2 setting of LED_1 0h = 0 1h = 0.39% 2h = 0.78% ... 80h = 50.2% ... FDh = 99.2% FEh = 99.6% FFh = 100%

2.12.5 LED_1_AEU1_PWM_3 Register (Offset = 9Eh) [Reset = 00h]

LED_1_AEU1_PWM_3 is shown in [Figure 2-65](#) and described in [Table 2-77](#).

Return to the [Summary Table](#).

Figure 2-65. LED_1_AEU1_PWM_3 Register

7	6	5	4	3	2	1	0
led_1_aeu1_pwm3							
R/W-0h							

Table 2-77. LED_1_AEU1_PWM_3 Register Field Descriptions

Bit	Field	Type	Reset	Description
7-0	led_1_aeu1_pwm3	R/W	0h	AEU1_PWM3 setting of LED_1 0h = 0 1h = 0.39% 2h = 0.78% ... 80h = 50.2% ... FDh = 99.2% FEh = 99.6% FFh = 100%

2.12.6 LED_1_AEU1_PWM_4 Register (Offset = 9Fh) [Reset = 00h]

LED_1_AEU1_PWM_4 is shown in [Figure 2-66](#) and described in [Table 2-78](#).

Return to the [Summary Table](#).

Figure 2-66. LED_1_AEU1_PWM_4 Register

7	6	5	4	3	2	1	0
led_1_aeu1_pwm4							
R/W-0h							

Table 2-78. LED_1_AEU1_PWM_4 Register Field Descriptions

Bit	Field	Type	Reset	Description
7-0	led_1_aeu1_pwm4	R/W	0h	AEU1_PWM4 setting of LED_1 0h = 0 1h = 0.39% 2h = 0.78% ... 80h = 50.2% ... FDh = 99.2% FEh = 99.6% FFh = 100%

2.12.7 LED_1_AEU1_PWM_5 Register (Offset = A0h) [Reset = 00h]

LED_1_AEU1_PWM_5 is shown in [Figure 2-67](#) and described in [Table 2-79](#).

Return to the [Summary Table](#).

Figure 2-67. LED_1_AEU1_PWM_5 Register

7	6	5	4	3	2	1	0
led_1_aeu1_pwm5							
R/W-0h							

Table 2-79. LED_1_AEU1_PWM_5 Register Field Descriptions

Bit	Field	Type	Reset	Description
7-0	led_1_aeu1_pwm5	R/W	0h	AEU1_PWM5 setting of LED_1 0h = 0 1h = 0.39% 2h = 0.78% ... 80h = 50.2% ... FDh = 99.2% FEh = 99.6% FFh = 100%

2.12.8 LED_1_AEU1_T12 Register (Offset = A1h) [Reset = 00h]

LED_1_AEU1_T12 is shown in [Figure 2-68](#) and described in [Table 2-80](#).

Return to the [Summary Table](#).

Figure 2-68. LED_1_AEU1_T12 Register

7	6	5	4	3	2	1	0
led_1_aeu1_t2				led_1_aeu1_t1			
R/W-0h				R/W-0h			

Table 2-80. LED_1_AEU1_T12 Register Field Descriptions

Bit	Field	Type	Reset	Description
7-4	led_1_aeu1_t2	R/W	0h	AEU1_T2 slope time setting of LED_1 0h = no pause time 1h = 0.09s 2h = 0.18s 3h = 0.36s 4h = 0.54s 5h = 0.80s 6h = 1.07s 7h = 1.52s 8h = 2.06s 9h = 2.50s Ah = 3.04s Bh = 4.02s Ch = 5.01s Dh = 5.99s Eh = 7.06s Fh = 8.05s
3-0	led_1_aeu1_t1	R/W	0h	AEU1_T1 slope time setting of LED_1 0h = no pause time 1h = 0.09s 2h = 0.18s 3h = 0.36s 4h = 0.54s 5h = 0.80s 6h = 1.07s 7h = 1.52s 8h = 2.06s 9h = 2.50s Ah = 3.04s Bh = 4.02s Ch = 5.01s Dh = 5.99s Eh = 7.06s Fh = 8.05s

2.12.9 LED_1_AEU1_T34 Register (Offset = A2h) [Reset = 00h]

LED_1_AEU1_T34 is shown in [Figure 2-69](#) and described in [Table 2-81](#).

Return to the [Summary Table](#).

Figure 2-69. LED_1_AEU1_T34 Register

7	6	5	4	3	2	1	0
led_1_aeu1_t4				led_1_aeu1_t3			
R/W-0h				R/W-0h			

Table 2-81. LED_1_AEU1_T34 Register Field Descriptions

Bit	Field	Type	Reset	Description
7-4	led_1_aeu1_t4	R/W	0h	AEU1_T4 slope time setting of LED_1 0h = no pause time 1h = 0.09s 2h = 0.18s 3h = 0.36s 4h = 0.54s 5h = 0.80s 6h = 1.07s 7h = 1.52s 8h = 2.06s 9h = 2.50s Ah = 3.04s Bh = 4.02s Ch = 5.01s Dh = 5.99s Eh = 7.06s Fh = 8.05s
3-0	led_1_aeu1_t3	R/W	0h	AEU1_T3 slope time setting of LED_1 0h = no pause time 1h = 0.09s 2h = 0.18s 3h = 0.36s 4h = 0.54s 5h = 0.80s 6h = 1.07s 7h = 1.52s 8h = 2.06s 9h = 2.50s Ah = 3.04s Bh = 4.02s Ch = 5.01s Dh = 5.99s Eh = 7.06s Fh = 8.05s

2.12.10 LED_1_AEU1_Playback Register (Offset = A3h) [Reset = 00h]

LED_1_AEU1_Playback is shown in [Figure 2-70](#) and described in [Table 2-82](#).

Return to the [Summary Table](#).

Figure 2-70. LED_1_AEU1_Playback Register

7	6	5	4	3	2	1	0
RESERVED						led_1_aeu1_pt	
R-0h						R/W-0h	

Table 2-82. LED_1_AEU1_Playback Register Field Descriptions

Bit	Field	Type	Reset	Description
7-2	RESERVED	R	0h	Reserved
1-0	led_1_aeu1_pt	R/W	0h	AEU1 pattern playback times of LED_1 0h = 0 time 1h = 1 time 2h = 2 times 3h = Infinite times

2.12.11 LED_1_AEU2_PWM_1 Register (Offset = A4h) [Reset = 00h]

LED_1_AEU2_PWM_1 is shown in [Figure 2-71](#) and described in [Table 2-83](#).

Return to the [Summary Table](#).

Figure 2-71. LED_1_AEU2_PWM_1 Register

7	6	5	4	3	2	1	0
led_1_aeu2_pwm1							
R/W-0h							

Table 2-83. LED_1_AEU2_PWM_1 Register Field Descriptions

Bit	Field	Type	Reset	Description
7-0	led_1_aeu2_pwm1	R/W	0h	AEU2_PWM1 setting of LED_1 0h = 0 1h = 0.39% 2h = 0.78% ... 80h = 50.2% ... FDh = 99.2% FEh = 99.6% FFh = 100%

2.12.12 LED_1_AEU2_PWM_2 Register (Offset = A5h) [Reset = 00h]

LED_1_AEU2_PWM_2 is shown in [Figure 2-72](#) and described in [Table 2-84](#).

Return to the [Summary Table](#).

Figure 2-72. LED_1_AEU2_PWM_2 Register

7	6	5	4	3	2	1	0
led_1_aeu2_pwm2							
R/W-0h							

Table 2-84. LED_1_AEU2_PWM_2 Register Field Descriptions

Bit	Field	Type	Reset	Description
7-0	led_1_aeu2_pwm2	R/W	0h	AEU2_PWM2 setting of LED_1 0h = 0 1h = 0.39% 2h = 0.78% ... 80h = 50.2% ... FDh = 99.2% FEh = 99.6% FFh = 100%

2.12.13 LED_1_AEU2_PWM_3 Register (Offset = A6h) [Reset = 00h]

LED_1_AEU2_PWM_3 is shown in [Figure 2-73](#) and described in [Table 2-85](#).

Return to the [Summary Table](#).

Figure 2-73. LED_1_AEU2_PWM_3 Register

7	6	5	4	3	2	1	0
led_1_aeu2_pwm3							
R/W-0h							

Table 2-85. LED_1_AEU2_PWM_3 Register Field Descriptions

Bit	Field	Type	Reset	Description
7-0	led_1_aeu2_pwm3	R/W	0h	AEU2_PWM3 setting of LED_1 0h = 0 1h = 0.39% 2h = 0.78% ... 80h = 50.2% ... FDh = 99.2% FEh = 99.6% FFh = 100%

2.12.14 LED_1_AEU2_PWM_4 Register (Offset = A7h) [Reset = 00h]

LED_1_AEU2_PWM_4 is shown in [Figure 2-74](#) and described in [Table 2-86](#).

Return to the [Summary Table](#).

Figure 2-74. LED_1_AEU2_PWM_4 Register

7	6	5	4	3	2	1	0
led_1_aeu2_pwm4							
R/W-0h							

Table 2-86. LED_1_AEU2_PWM_4 Register Field Descriptions

Bit	Field	Type	Reset	Description
7-0	led_1_aeu2_pwm4	R/W	0h	AEU2_PWM4 setting of LED_1 0h = 0 1h = 0.39% 2h = 0.78% ... 80h = 50.2% ... FDh = 99.2% FEh = 99.6% FFh = 100%

2.12.15 LED_1_AEU2_PWM_5 Register (Offset = A8h) [Reset = 00h]

LED_1_AEU2_PWM_5 is shown in [Figure 2-75](#) and described in [Table 2-87](#).

Return to the [Summary Table](#).

Figure 2-75. LED_1_AEU2_PWM_5 Register

7	6	5	4	3	2	1	0
led_1_aeu2_pwm5							
R/W-0h							

Table 2-87. LED_1_AEU2_PWM_5 Register Field Descriptions

Bit	Field	Type	Reset	Description
7-0	led_1_aeu2_pwm5	R/W	0h	AEU2_PWM5 setting of LED_1 0h = 0 1h = 0.39% 2h = 0.78% ... 80h = 50.2% ... FDh = 99.2% FEh = 99.6% FFh = 100%

2.12.16 LED_1_AEU2_T12 Register (Offset = A9h) [Reset = 00h]

LED_1_AEU2_T12 is shown in [Figure 2-76](#) and described in [Table 2-88](#).

Return to the [Summary Table](#).

Figure 2-76. LED_1_AEU2_T12 Register

7	6	5	4	3	2	1	0
led_1_aeu2_t2				led_1_aeu2_t1			
R/W-0h				R/W-0h			

Table 2-88. LED_1_AEU2_T12 Register Field Descriptions

Bit	Field	Type	Reset	Description
7-4	led_1_aeu2_t2	R/W	0h	AEU2_T2 slope time setting of LED_1 0h = no pause time 1h = 0.09s 2h = 0.18s 3h = 0.36s 4h = 0.54s 5h = 0.80s 6h = 1.07s 7h = 1.52s 8h = 2.06s 9h = 2.50s Ah = 3.04s Bh = 4.02s Ch = 5.01s Dh = 5.99s Eh = 7.06s Fh = 8.05s
3-0	led_1_aeu2_t1	R/W	0h	AEU2_T1 slope time setting of LED_1 0h = no pause time 1h = 0.09s 2h = 0.18s 3h = 0.36s 4h = 0.54s 5h = 0.80s 6h = 1.07s 7h = 1.52s 8h = 2.06s 9h = 2.50s Ah = 3.04s Bh = 4.02s Ch = 5.01s Dh = 5.99s Eh = 7.06s Fh = 8.05s

2.12.17 LED_1_AEU2_T34 Register (Offset = AAh) [Reset = 00h]

LED_1_AEU2_T34 is shown in [Figure 2-77](#) and described in [Table 2-89](#).

Return to the [Summary Table](#).

Figure 2-77. LED_1_AEU2_T34 Register

7	6	5	4	3	2	1	0
led_1_aeu2_t4				led_1_aeu2_t3			
R/W-0h				R/W-0h			

Table 2-89. LED_1_AEU2_T34 Register Field Descriptions

Bit	Field	Type	Reset	Description
7-4	led_1_aeu2_t4	R/W	0h	AEU2_T4 slope time setting of LED_1 0h = no pause time 1h = 0.09s 2h = 0.18s 3h = 0.36s 4h = 0.54s 5h = 0.80s 6h = 1.07s 7h = 1.52s 8h = 2.06s 9h = 2.50s Ah = 3.04s Bh = 4.02s Ch = 5.01s Dh = 5.99s Eh = 7.06s Fh = 8.05s
3-0	led_1_aeu2_t3	R/W	0h	AEU2_T3 slope time setting of LED_1 0h = no pause time 1h = 0.09s 2h = 0.18s 3h = 0.36s 4h = 0.54s 5h = 0.80s 6h = 1.07s 7h = 1.52s 8h = 2.06s 9h = 2.50s Ah = 3.04s Bh = 4.02s Ch = 5.01s Dh = 5.99s Eh = 7.06s Fh = 8.05s

2.12.18 LED_1_AEU2_Playback Register (Offset = ABh) [Reset = 00h]

LED_1_AEU2_Playback is shown in [Figure 2-78](#) and described in [Table 2-90](#).

Return to the [Summary Table](#).

Figure 2-78. LED_1_AEU2_Playback Register

7	6	5	4	3	2	1	0
RESERVED						led_1_aeu2_pt	
R-0h						R/W-0h	

Table 2-90. LED_1_AEU2_Playback Register Field Descriptions

Bit	Field	Type	Reset	Description
7-2	RESERVED	R	0h	Reserved
1-0	led_1_aeu2_pt	R/W	0h	AEU2 pattern playback times of LED_1 0h = 0 time 1h = 1 time 2h = 2 times 3h = Infinite times

2.12.19 LED_1_AEU3_PWM_1 Register (Offset = ACh) [Reset = 00h]

LED_1_AEU3_PWM_1 is shown in [Figure 2-79](#) and described in [Table 2-91](#).

Return to the [Summary Table](#).

Figure 2-79. LED_1_AEU3_PWM_1 Register

7	6	5	4	3	2	1	0
led_1_aeu3_pwm1							
R/W-0h							

Table 2-91. LED_1_AEU3_PWM_1 Register Field Descriptions

Bit	Field	Type	Reset	Description
7-0	led_1_aeu3_pwm1	R/W	0h	AEU3_PWM1 setting of LED_1 0h = 0 1h = 0.39% 2h = 0.78% ... 80h = 50.2% ... FDh = 99.2% FEh = 99.6% FFh = 100%

2.12.20 LED_1_AEU3_PWM_2 Register (Offset = ADh) [Reset = 00h]

LED_1_AEU3_PWM_2 is shown in [Figure 2-80](#) and described in [Table 2-92](#).

Return to the [Summary Table](#).

Figure 2-80. LED_1_AEU3_PWM_2 Register

7	6	5	4	3	2	1	0
led_1_aeu3_pwm2							
R/W-0h							

Table 2-92. LED_1_AEU3_PWM_2 Register Field Descriptions

Bit	Field	Type	Reset	Description
7-0	led_1_aeu3_pwm2	R/W	0h	AEU3_PWM2 setting of LED_1 0h = 0 1h = 0.39% 2h = 0.78% ... 80h = 50.2% ... FDh = 99.2% FEh = 99.6% FFh = 100%

2.12.21 LED_1_AEU3_PWM_3 Register (Offset = AEh) [Reset = 00h]

LED_1_AEU3_PWM_3 is shown in [Figure 2-81](#) and described in [Table 2-93](#).

Return to the [Summary Table](#).

Figure 2-81. LED_1_AEU3_PWM_3 Register

7	6	5	4	3	2	1	0
led_1_aeu3_pwm3							
R/W-0h							

Table 2-93. LED_1_AEU3_PWM_3 Register Field Descriptions

Bit	Field	Type	Reset	Description
7-0	led_1_aeu3_pwm3	R/W	0h	AEU3_PWM3 setting of LED_1 0h = 0 1h = 0.39% 2h = 0.78% ... 80h = 50.2% ... FDh = 99.2% FEh = 99.6% FFh = 100%

2.12.22 LED_1_AEU3_PWM_4 Register (Offset = AFh) [Reset = 00h]

LED_1_AEU3_PWM_4 is shown in [Figure 2-82](#) and described in [Table 2-94](#).

Return to the [Summary Table](#).

Figure 2-82. LED_1_AEU3_PWM_4 Register

7	6	5	4	3	2	1	0
led_1_aeu3_pwm4							
R/W-0h							

Table 2-94. LED_1_AEU3_PWM_4 Register Field Descriptions

Bit	Field	Type	Reset	Description
7-0	led_1_aeu3_pwm4	R/W	0h	AEU3_PWM4 setting of LED_1 0h = 0 1h = 0.39% 2h = 0.78% ... 80h = 50.2% ... FDh = 99.2% FEh = 99.6% FFh = 100%

2.12.23 LED_1_AEU3_PWM_5 Register (Offset = B0h) [Reset = 00h]

LED_1_AEU3_PWM_5 is shown in [Figure 2-83](#) and described in [Table 2-95](#).

Return to the [Summary Table](#).

Figure 2-83. LED_1_AEU3_PWM_5 Register

7	6	5	4	3	2	1	0
led_1_aeu3_pwm5							
R/W-0h							

Figure 2-83. LED_1_AEU3_PWM_5 Register (continued)
Table 2-95. LED_1_AEU3_PWM_5 Register Field Descriptions

Bit	Field	Type	Reset	Description
7-0	led_1_aeu3_pwm5	R/W	0h	AEU3_PWM5 setting of LED_1 0h = 0 1h = 0.39% 2h = 0.78% ... 80h = 50.2% ... FDh = 99.2% FEh = 99.6% FFh = 100%

2.12.24 LED_1_AEU3_T12 Register (Offset = B1h) [Reset = 00h]

LED_1_AEU3_T12 is shown in [Figure 2-84](#) and described in [Table 2-96](#).

Return to the [Summary Table](#).

Figure 2-84. LED_1_AEU3_T12 Register

7	6	5	4	3	2	1	0
led_1_aeu3_t2				led_1_aeu3_t1			
R/W-0h				R/W-0h			

Table 2-96. LED_1_AEU3_T12 Register Field Descriptions

Bit	Field	Type	Reset	Description
7-4	led_1_aeu3_t2	R/W	0h	AEU3_T2 slope time setting of LED_1 0h = no pause time 1h = 0.09s 2h = 0.18s 3h = 0.36s 4h = 0.54s 5h = 0.80s 6h = 1.07s 7h = 1.52s 8h = 2.06s 9h = 2.50s Ah = 3.04s Bh = 4.02s Ch = 5.01s Dh = 5.99s Eh = 7.06s Fh = 8.05s

Table 2-96. LED_1_AEU3_T12 Register Field Descriptions (continued)

Bit	Field	Type	Reset	Description
3-0	led_1_aeu3_t1	R/W	0h	AEU3_T1 slope time setting of LED_1 0h = no pause time 1h = 0.09s 2h = 0.18s 3h = 0.36s 4h = 0.54s 5h = 0.80s 6h = 1.07s 7h = 1.52s 8h = 2.06s 9h = 2.50s Ah = 3.04s Bh = 4.02s Ch = 5.01s Dh = 5.99s Eh = 7.06s Fh = 8.05s

2.12.25 LED_1_AEU3_T34 Register (Offset = B2h) [Reset = 00h]

LED_1_AEU3_T34 is shown in [Figure 2-85](#) and described in [Table 2-97](#).

Return to the [Summary Table](#).

Figure 2-85. LED_1_AEU3_T34 Register

7	6	5	4	3	2	1	0
led_1_aeu3_t4				led_1_aeu3_t3			
R/W-0h				R/W-0h			

Table 2-97. LED_1_AEU3_T34 Register Field Descriptions

Bit	Field	Type	Reset	Description
7-4	led_1_aeu3_t4	R/W	0h	AEU3_T4 slope time setting of LED_1 0h = no pause time 1h = 0.09s 2h = 0.18s 3h = 0.36s 4h = 0.54s 5h = 0.80s 6h = 1.07s 7h = 1.52s 8h = 2.06s 9h = 2.50s Ah = 3.04s Bh = 4.02s Ch = 5.01s Dh = 5.99s Eh = 7.06s Fh = 8.05s

Table 2-97. LED_1_AEU3_T34 Register Field Descriptions (continued)

Bit	Field	Type	Reset	Description
3-0	led_1_aeu3_t3	R/W	0h	AEU3_T3 slope time setting of LED_1 0h = no pause time 1h = 0.09s 2h = 0.18s 3h = 0.36s 4h = 0.54s 5h = 0.80s 6h = 1.07s 7h = 1.52s 8h = 2.06s 9h = 2.50s Ah = 3.04s Bh = 4.02s Ch = 5.01s Dh = 5.99s Eh = 7.06s Fh = 8.05s

2.12.26 LED_1_AEU3_Playback Register (Offset = B3h) [Reset = 00h]

LED_1_AEU3_Playback is shown in [Figure 2-86](#) and described in [Table 2-98](#).

Return to the [Summary Table](#).

Figure 2-86. LED_1_AEU3_Playback Register

7	6	5	4	3	2	1	0
RESERVED						led_1_aeu3_pt	
R-0h						R/W-0h	

Table 2-98. LED_1_AEU3_Playback Register Field Descriptions

Bit	Field	Type	Reset	Description
7-2	RESERVED	R	0h	Reserved
1-0	led_1_aeu3_pt	R/W	0h	AEU3 pattern playback times of LED_1 0h = 0 time 1h = 1 time 2h = 2 times 3h = Infinite times

2.13 LED_2_Autonomous_Animation Registers

Table 2-99 lists the memory-mapped registers for the LED_2_Autonomous_Animation registers. All register offset addresses not listed in Table 2-99 should be considered as reserved locations and the register contents should not be modified.

Table 2-99. LED_2_AUTONOMOUS_ANIMATION Registers

Offset	Acronym	Register Name	Section
B4h	LED_2_Auto_Pause	Animation pause time at the start and the end of LED_2	Go
B5h	LED_2_Auto_Playback	Animation pattern playback times of LED_2 and active AEU number setting	Go
B6h	LED_2_AEU1_PWM_1	PWM setting of LED_2 AEU1_PWM1	Go
B7h	LED_2_AEU1_PWM_2	PWM setting of LED_2 AEU1_PWM2	Go
B8h	LED_2_AEU1_PWM_3	PWM setting of LED_2 AEU1_PWM3	Go
B9h	LED_2_AEU1_PWM_4	PWM setting of LED_2 AEU1_PWM4	Go
BAh	LED_2_AEU1_PWM_5	PWM setting of LED_2 AEU1_PWM5	Go
BBh	LED_2_AEU1_T12	Slope time setting of LED_2 AEU1_T1 and AEU1_T2	Go
BCh	LED_2_AEU1_T34	Slope time setting of LED_2 AEU1_T3 and AEU1_T4	Go
BDh	LED_2_AEU1_Playback	AEU1 pattern playback times of LED_2	Go
BEh	LED_2_AEU2_PWM_1	PWM setting of LED_2 AEU2_PWM1	Go
BFh	LED_2_AEU2_PWM_2	PWM setting of LED_2 AEU2_PWM2	Go
C0h	LED_2_AEU2_PWM_3	PWM setting of LED_2 AEU2_PWM3	Go
C1h	LED_2_AEU2_PWM_4	PWM setting of LED_2 AEU2_PWM4	Go
C2h	LED_2_AEU2_PWM_5	PWM setting of LED_2 AEU2_PWM5	Go
C3h	LED_2_AEU2_T12	Slope time setting of LED_2 AEU2_T1 and AEU2_T2	Go
C4h	LED_2_AEU2_T34	Slope time setting of LED_2 AEU2_T3 and AEU2_T4	Go
C5h	LED_2_AEU2_Playback	AEU2 pattern playback times of LED_2	Go
C6h	LED_2_AEU3_PWM_1	PWM setting of LED_2 AEU3_PWM1	Go
C7h	LED_2_AEU3_PWM_2	PWM setting of LED_2 AEU3_PWM2	Go
C8h	LED_2_AEU3_PWM_3	PWM setting of LED_2 AEU3_PWM3	Go
C9h	LED_2_AEU3_PWM_4	PWM setting of LED_2 AEU3_PWM4	Go
CAh	LED_2_AEU3_PWM_5	PWM setting of LED_2 AEU3_PWM5	Go
CBh	LED_2_AEU3_T12	Slope time setting of LED_2 AEU3_T1 and AEU3_T2	Go
CCh	LED_2_AEU3_T34	Slope time setting of LED_2 AEU3_T3 and AEU3_T4	Go
CDh	LED_2_AEU3_Playback	AEU3 pattern playback times of LED_2	Go

2.13.1 LED_2_Auto_Pause Register (Offset = B4h) [Reset = 00h]

LED_2_Auto_Pause is shown in Figure 2-87 and described in Table 2-100.

Return to the [Summary Table](#).

Figure 2-87. LED_2_Auto_Pause Register

7	6	5	4	3	2	1	0
led_2_tp_ts				led_2_tp_te			
R/W-0h				R/W-0h			

Table 2-100. LED_2_Auto_Pause Register Field Descriptions

Bit	Field	Type	Reset	Description
7-4	led_2_tp_ts	R/W	0h	Animation pause time at the start of LED_2 0h = no pause time 1h = 0.09s 2h = 0.18s 3h = 0.36s 4h = 0.54s 5h = 0.80s 6h = 1.07s 7h = 1.52s 8h = 2.06s 9h = 2.50s Ah = 3.04s Bh = 4.02s Ch = 5.01s Dh = 5.99s Eh = 7.06s Fh = 8.05s
3-0	led_2_tp_te	R/W	0h	Animation pause time at the end of LED_2 0h = no pause time 1h = 0.09s 2h = 0.18s 3h = 0.36s 4h = 0.54s 5h = 0.80s 6h = 1.07s 7h = 1.52s 8h = 2.06s 9h = 2.50s Ah = 3.04s Bh = 4.02s Ch = 5.01s Dh = 5.99s Eh = 7.06s Fh = 8.05s

2.13.2 LED_2_Auto_Playback Register (Offset = B5h) [Reset = 00h]

LED_2_Auto_Playback is shown in [Figure 2-88](#) and described in [Table 2-101](#).

Return to the [Summary Table](#).

Figure 2-88. LED_2_Auto_Playback Register

7	6	5	4	3	2	1	0
RESERVED		led_2_aeu_num		led_2_pt			
R-0h		R/W-0h		R/W-0h			

Table 2-101. LED_2_Auto_Playback Register Field Descriptions

Bit	Field	Type	Reset	Description
7-6	RESERVED	R	0h	Reserved
5-4	led_2_aeu_num	R/W	0h	Active AEU number of LED_2 selection 0h = only use AEU1 1h = use AEU1 and AEU2 2h = use AEU1, AEU2 and AEU3 3h = use AEU1, AEU2 and AEU3 (the same as 2h)

Table 2-101. LED_2_Auto_Playback Register Field Descriptions (continued)

Bit	Field	Type	Reset	Description
3-0	led_2_pt	R/W	0h	Animation pattern playback times of LED_2 0h = 0 times 1h = 1 times 2h = 2 times 3h = 3 times 4h = 4 times 5h = 5 times 6h = 6 times 7h = 7 times 8h = 8 times 9h = 9 times Ah = 10 times Bh = 11 times Ch = 12 times Dh = 13 times Eh = 14 times Fh = infinite times

2.13.3 LED_2_AEU1_PWM_1 Register (Offset = B6h) [Reset = 00h]

LED_2_AEU1_PWM_1 is shown in [Figure 2-89](#) and described in [Table 2-102](#).

Return to the [Summary Table](#).

Figure 2-89. LED_2_AEU1_PWM_1 Register

7	6	5	4	3	2	1	0
led_2_aeu1_pwm1							
R/W-0h							

Table 2-102. LED_2_AEU1_PWM_1 Register Field Descriptions

Bit	Field	Type	Reset	Description
7-0	led_2_aeu1_pwm1	R/W	0h	AEU1_PWM1 setting of LED_2 0h = 0 1h = 0.39% 2h = 0.78% ... 80h = 50.2% ... FDh = 99.2% FEh = 99.6% FFh = 100%

2.13.4 LED_2_AEU1_PWM_2 Register (Offset = B7h) [Reset = 00h]

LED_2_AEU1_PWM_2 is shown in [Figure 2-90](#) and described in [Table 2-103](#).

Return to the [Summary Table](#).

Figure 2-90. LED_2_AEU1_PWM_2 Register

7	6	5	4	3	2	1	0
led_2_aeu1_pwm2							
R/W-0h							

Table 2-103. LED_2_AEU1_PWM_2 Register Field Descriptions

Bit	Field	Type	Reset	Description
7-0	led_2_aeu1_pwm2	R/W	0h	AEU1_PWM2 setting of LED_2 0h = 0 1h = 0.39% 2h = 0.78% ... 80h = 50.2% ... FDh = 99.2% FEh = 99.6% FFh = 100%

2.13.5 LED_2_AEU1_PWM_3 Register (Offset = B8h) [Reset = 00h]

LED_2_AEU1_PWM_3 is shown in [Figure 2-91](#) and described in [Table 2-104](#).

Return to the [Summary Table](#).

Figure 2-91. LED_2_AEU1_PWM_3 Register

7	6	5	4	3	2	1	0
led_2_aeu1_pwm3							
R/W-0h							

Table 2-104. LED_2_AEU1_PWM_3 Register Field Descriptions

Bit	Field	Type	Reset	Description
7-0	led_2_aeu1_pwm3	R/W	0h	AEU1_PWM3 setting of LED_2 0h = 0 1h = 0.39% 2h = 0.78% ... 80h = 50.2% ... FDh = 99.2% FEh = 99.6% FFh = 100%

2.13.6 LED_2_AEU1_PWM_4 Register (Offset = B9h) [Reset = 00h]

LED_2_AEU1_PWM_4 is shown in [Figure 2-92](#) and described in [Table 2-105](#).

Return to the [Summary Table](#).

Figure 2-92. LED_2_AEU1_PWM_4 Register

7	6	5	4	3	2	1	0
led_2_aeu1_pwm4							
R/W-0h							

Table 2-105. LED_2_AEU1_PWM_4 Register Field Descriptions

Bit	Field	Type	Reset	Description
7-0	led_2_aeu1_pwm4	R/W	0h	AEU1_PWM4 setting of LED_2 0h = 0 1h = 0.39% 2h = 0.78% ... 80h = 50.2% ... FDh = 99.2% FEh = 99.6% FFh = 100%

2.13.7 LED_2_AEU1_PWM_5 Register (Offset = BAh) [Reset = 00h]

LED_2_AEU1_PWM_5 is shown in [Figure 2-93](#) and described in [Table 2-106](#).

Return to the [Summary Table](#).

Figure 2-93. LED_2_AEU1_PWM_5 Register

7	6	5	4	3	2	1	0
led_2_aeu1_pwm5							
R/W-0h							

Table 2-106. LED_2_AEU1_PWM_5 Register Field Descriptions

Bit	Field	Type	Reset	Description
7-0	led_2_aeu1_pwm5	R/W	0h	AEU1_PWM5 setting of LED_2 0h = 0 1h = 0.39% 2h = 0.78% ... 80h = 50.2% ... FDh = 99.2% FEh = 99.6% FFh = 100%

2.13.8 LED_2_AEU1_T12 Register (Offset = BBh) [Reset = 00h]

LED_2_AEU1_T12 is shown in [Figure 2-94](#) and described in [Table 2-107](#).

Return to the [Summary Table](#).

Figure 2-94. LED_2_AEU1_T12 Register

7	6	5	4	3	2	1	0
led_2_aeu1_t2				led_2_aeu1_t1			
R/W-0h				R/W-0h			

Table 2-107. LED_2_AEU1_T12 Register Field Descriptions

Bit	Field	Type	Reset	Description
7-4	led_2_aeu1_t2	R/W	0h	AEU1_T2 slope time setting of LED_2 0h = no pause time 1h = 0.09s 2h = 0.18s 3h = 0.36s 4h = 0.54s 5h = 0.80s 6h = 1.07s 7h = 1.52s 8h = 2.06s 9h = 2.50s Ah = 3.04s Bh = 4.02s Ch = 5.01s Dh = 5.99s Eh = 7.06s Fh = 8.05s
3-0	led_2_aeu1_t1	R/W	0h	AEU1_T1 slope time setting of LED_2 0h = no pause time 1h = 0.09s 2h = 0.18s 3h = 0.36s 4h = 0.54s 5h = 0.80s 6h = 1.07s 7h = 1.52s 8h = 2.06s 9h = 2.50s Ah = 3.04s Bh = 4.02s Ch = 5.01s Dh = 5.99s Eh = 7.06s Fh = 8.05s

2.13.9 LED_2_AEU1_T34 Register (Offset = BCh) [Reset = 00h]

LED_2_AEU1_T34 is shown in [Figure 2-95](#) and described in [Table 2-108](#).

Return to the [Summary Table](#).

Figure 2-95. LED_2_AEU1_T34 Register

7	6	5	4	3	2	1	0
led_2_aeu1_t4				led_2_aeu1_t3			
R/W-0h				R/W-0h			

Table 2-108. LED_2_AEU1_T34 Register Field Descriptions

Bit	Field	Type	Reset	Description
7-4	led_2_aeu1_t4	R/W	0h	AEU1_T4 slope time setting of LED_2 0h = no pause time 1h = 0.09s 2h = 0.18s 3h = 0.36s 4h = 0.54s 5h = 0.80s 6h = 1.07s 7h = 1.52s 8h = 2.06s 9h = 2.50s Ah = 3.04s Bh = 4.02s Ch = 5.01s Dh = 5.99s Eh = 7.06s Fh = 8.05s
3-0	led_2_aeu1_t3	R/W	0h	AEU1_T3 slope time setting of LED_2 0h = no pause time 1h = 0.09s 2h = 0.18s 3h = 0.36s 4h = 0.54s 5h = 0.80s 6h = 1.07s 7h = 1.52s 8h = 2.06s 9h = 2.50s Ah = 3.04s Bh = 4.02s Ch = 5.01s Dh = 5.99s Eh = 7.06s Fh = 8.05s

2.13.10 LED_2_AEU1_Playback Register (Offset = BDh) [Reset = 00h]

LED_2_AEU1_Playback is shown in [Figure 2-96](#) and described in [Table 2-109](#).

Return to the [Summary Table](#).

Figure 2-96. LED_2_AEU1_Playback Register

7	6	5	4	3	2	1	0
RESERVED						led_2_aeu1_pt	
R-0h						R/W-0h	

Table 2-109. LED_2_AEU1_Playback Register Field Descriptions

Bit	Field	Type	Reset	Description
7-2	RESERVED	R	0h	Reserved
1-0	led_2_aeu1_pt	R/W	0h	AEU1 pattern playback times of LED_2 0h = 0 time 1h = 1 time 2h = 2 times 3h = Infinite times

2.13.11 LED_2_AEU2_PWM_1 Register (Offset = BEh) [Reset = 00h]

LED_2_AEU2_PWM_1 is shown in [Figure 2-97](#) and described in [Table 2-110](#).

Return to the [Summary Table](#).

Figure 2-97. LED_2_AEU2_PWM_1 Register

7	6	5	4	3	2	1	0
led_2_aeu2_pwm1							
R/W-0h							

Table 2-110. LED_2_AEU2_PWM_1 Register Field Descriptions

Bit	Field	Type	Reset	Description
7-0	led_2_aeu2_pwm1	R/W	0h	AEU2_PWM1 setting of LED_2 0h = 0 1h = 0.39% 2h = 0.78% ... 80h = 50.2% ... FDh = 99.2% FEh = 99.6% FFh = 100%

2.13.12 LED_2_AEU2_PWM_2 Register (Offset = BFh) [Reset = 00h]

LED_2_AEU2_PWM_2 is shown in [Figure 2-98](#) and described in [Table 2-111](#).

Return to the [Summary Table](#).

Figure 2-98. LED_2_AEU2_PWM_2 Register

7	6	5	4	3	2	1	0
led_2_aeu2_pwm2							
R/W-0h							

Table 2-111. LED_2_AEU2_PWM_2 Register Field Descriptions

Bit	Field	Type	Reset	Description
7-0	led_2_aeu2_pwm2	R/W	0h	AEU2_PWM2 setting of LED_2 0h = 0 1h = 0.39% 2h = 0.78% ... 80h = 50.2% ... FDh = 99.2% FEh = 99.6% FFh = 100%

2.13.13 LED_2_AEU2_PWM_3 Register (Offset = C0h) [Reset = 00h]

LED_2_AEU2_PWM_3 is shown in [Figure 2-99](#) and described in [Table 2-112](#).

Return to the [Summary Table](#).

Figure 2-99. LED_2_AEU2_PWM_3 Register

7	6	5	4	3	2	1	0
led_2_aeu2_pwm3							
R/W-0h							

Table 2-112. LED_2_AEU2_PWM_3 Register Field Descriptions

Bit	Field	Type	Reset	Description
7-0	led_2_aeu2_pwm3	R/W	0h	AEU2_PWM3 setting of LED_2 0h = 0 1h = 0.39% 2h = 0.78% ... 80h = 50.2% ... FDh = 99.2% FEh = 99.6% FFh = 100%

2.13.14 LED_2_AEU2_PWM_4 Register (Offset = C1h) [Reset = 00h]

LED_2_AEU2_PWM_4 is shown in [Figure 2-100](#) and described in [Table 2-113](#).

Return to the [Summary Table](#).

Figure 2-100. LED_2_AEU2_PWM_4 Register

7	6	5	4	3	2	1	0
led_2_aeu2_pwm4							
R/W-0h							

Table 2-113. LED_2_AEU2_PWM_4 Register Field Descriptions

Bit	Field	Type	Reset	Description
7-0	led_2_aeu2_pwm4	R/W	0h	AEU2_PWM4 setting of LED_2 0h = 0 1h = 0.39% 2h = 0.78% ... 80h = 50.2% ... FDh = 99.2% FEh = 99.6% FFh = 100%

2.13.15 LED_2_AEU2_PWM_5 Register (Offset = C2h) [Reset = 00h]

LED_2_AEU2_PWM_5 is shown in [Figure 2-101](#) and described in [Table 2-114](#).

Return to the [Summary Table](#).

Figure 2-101. LED_2_AEU2_PWM_5 Register

7	6	5	4	3	2	1	0
led_2_aeu2_pwm5							
R/W-0h							

Table 2-114. LED_2_AEU2_PWM_5 Register Field Descriptions

Bit	Field	Type	Reset	Description
7-0	led_2_aeu2_pwm5	R/W	0h	AEU2_PWM5 setting of LED_2 0h = 0 1h = 0.39% 2h = 0.78% ... 80h = 50.2% ... FDh = 99.2% FEh = 99.6% FFh = 100%

2.13.16 LED_2_AEU2_T12 Register (Offset = C3h) [Reset = 00h]

 LED_2_AEU2_T12 is shown in [Figure 2-102](#) and described in [Table 2-115](#).

 Return to the [Summary Table](#).

Figure 2-102. LED_2_AEU2_T12 Register

7	6	5	4	3	2	1	0
led_2_aeu2_t2				led_2_aeu2_t1			
R/W-0h				R/W-0h			

Table 2-115. LED_2_AEU2_T12 Register Field Descriptions

Bit	Field	Type	Reset	Description
7-4	led_2_aeu2_t2	R/W	0h	AEU2_T2 slope time setting of LED_2 0h = no pause time 1h = 0.09s 2h = 0.18s 3h = 0.36s 4h = 0.54s 5h = 0.80s 6h = 1.07s 7h = 1.52s 8h = 2.06s 9h = 2.50s Ah = 3.04s Bh = 4.02s Ch = 5.01s Dh = 5.99s Eh = 7.06s Fh = 8.05s
3-0	led_2_aeu2_t1	R/W	0h	AEU2_T1 slope time setting of LED_2 0h = no pause time 1h = 0.09s 2h = 0.18s 3h = 0.36s 4h = 0.54s 5h = 0.80s 6h = 1.07s 7h = 1.52s 8h = 2.06s 9h = 2.50s Ah = 3.04s Bh = 4.02s Ch = 5.01s Dh = 5.99s Eh = 7.06s Fh = 8.05s

2.13.17 LED_2_AEU2_T34 Register (Offset = C4h) [Reset = 00h]

LED_2_AEU2_T34 is shown in [Figure 2-103](#) and described in [Table 2-116](#).

Return to the [Summary Table](#).

Figure 2-103. LED_2_AEU2_T34 Register

7	6	5	4	3	2	1	0
led_2_aeu2_t4				led_2_aeu2_t3			
R/W-0h				R/W-0h			

Table 2-116. LED_2_AEU2_T34 Register Field Descriptions

Bit	Field	Type	Reset	Description
7-4	led_2_aeu2_t4	R/W	0h	AEU2_T4 slope time setting of LED_2 0h = no pause time 1h = 0.09s 2h = 0.18s 3h = 0.36s 4h = 0.54s 5h = 0.80s 6h = 1.07s 7h = 1.52s 8h = 2.06s 9h = 2.50s Ah = 3.04s Bh = 4.02s Ch = 5.01s Dh = 5.99s Eh = 7.06s Fh = 8.05s
3-0	led_2_aeu2_t3	R/W	0h	AEU2_T3 slope time setting of LED_2 0h = no pause time 1h = 0.09s 2h = 0.18s 3h = 0.36s 4h = 0.54s 5h = 0.80s 6h = 1.07s 7h = 1.52s 8h = 2.06s 9h = 2.50s Ah = 3.04s Bh = 4.02s Ch = 5.01s Dh = 5.99s Eh = 7.06s Fh = 8.05s

2.13.18 LED_2_AEU2_Playback Register (Offset = C5h) [Reset = 00h]

LED_2_AEU2_Playback is shown in [Figure 2-104](#) and described in [Table 2-117](#).

Return to the [Summary Table](#).

Figure 2-104. LED_2_AEU2_Playback Register

7	6	5	4	3	2	1	0
RESERVED						led_2_aeu2_pt	
R-0h						R/W-0h	

Table 2-117. LED_2_AEU2_Playback Register Field Descriptions

Bit	Field	Type	Reset	Description
7-2	RESERVED	R	0h	Reserved
1-0	led_2_aeu2_pt	R/W	0h	AEU2 pattern playback times of LED_2 0h = 0 time 1h = 1 time 2h = 2 times 3h = Infinite times

2.13.19 LED_2_AEU3_PWM_1 Register (Offset = C6h) [Reset = 00h]

LED_2_AEU3_PWM_1 is shown in [Figure 2-105](#) and described in [Table 2-118](#).

Return to the [Summary Table](#).

Figure 2-105. LED_2_AEU3_PWM_1 Register

7	6	5	4	3	2	1	0
led_2_aeu3_pwm1							
R/W-0h							

Table 2-118. LED_2_AEU3_PWM_1 Register Field Descriptions

Bit	Field	Type	Reset	Description
7-0	led_2_aeu3_pwm1	R/W	0h	AEU3_PWM1 setting of LED_2 0h = 0 1h = 0.39% 2h = 0.78% ... 80h = 50.2% ... FDh = 99.2% FEh = 99.6% FFh = 100%

2.13.20 LED_2_AEU3_PWM_2 Register (Offset = C7h) [Reset = 00h]

LED_2_AEU3_PWM_2 is shown in [Figure 2-106](#) and described in [Table 2-119](#).

Return to the [Summary Table](#).

Figure 2-106. LED_2_AEU3_PWM_2 Register

7	6	5	4	3	2	1	0
led_2_aeu3_pwm2							
R/W-0h							

Table 2-119. LED_2_AEU3_PWM_2 Register Field Descriptions

Bit	Field	Type	Reset	Description
7-0	led_2_aeu3_pwm2	R/W	0h	AEU3_PWM2 setting of LED_2 0h = 0 1h = 0.39% 2h = 0.78% ... 80h = 50.2% ... FDh = 99.2% FEh = 99.6% FFh = 100%

2.13.21 LED_2_AEU3_PWM_3 Register (Offset = C8h) [Reset = 00h]

LED_2_AEU3_PWM_3 is shown in [Figure 2-107](#) and described in [Table 2-120](#).

Return to the [Summary Table](#).

Figure 2-107. LED_2_AEU3_PWM_3 Register

7	6	5	4	3	2	1	0
led_2_aeu3_pwm3							
R/W-0h							

Table 2-120. LED_2_AEU3_PWM_3 Register Field Descriptions

Bit	Field	Type	Reset	Description
7-0	led_2_aeu3_pwm3	R/W	0h	AEU3_PWM3 setting of LED_2 0h = 0 1h = 0.39% 2h = 0.78% ... 80h = 50.2% ... FDh = 99.2% FEh = 99.6% FFh = 100%

2.13.22 LED_2_AEU3_PWM_4 Register (Offset = C9h) [Reset = 00h]

LED_2_AEU3_PWM_4 is shown in [Figure 2-108](#) and described in [Table 2-121](#).

Return to the [Summary Table](#).

Figure 2-108. LED_2_AEU3_PWM_4 Register

7	6	5	4	3	2	1	0
led_2_aeu3_pwm4							
R/W-0h							

Table 2-121. LED_2_AEU3_PWM_4 Register Field Descriptions

Bit	Field	Type	Reset	Description
7-0	led_2_aeu3_pwm4	R/W	0h	AEU3_PWM4 setting of LED_2 0h = 0 1h = 0.39% 2h = 0.78% ... 80h = 50.2% ... FDh = 99.2% FEh = 99.6% FFh = 100%

2.13.23 LED_2_AEU3_PWM_5 Register (Offset = CAh) [Reset = 00h]

LED_2_AEU3_PWM_5 is shown in [Figure 2-109](#) and described in [Table 2-122](#).

Return to the [Summary Table](#).

Figure 2-109. LED_2_AEU3_PWM_5 Register

7	6	5	4	3	2	1	0
led_2_aeu3_pwm5							
R/W-0h							

Figure 2-109. LED_2_AEU3_PWM_5 Register (continued)
Table 2-122. LED_2_AEU3_PWM_5 Register Field Descriptions

Bit	Field	Type	Reset	Description
7-0	led_2_aeu3_pwm5	R/W	0h	AEU3_PWM5 setting of LED_2 0h = 0 1h = 0.39% 2h = 0.78% ... 80h = 50.2% ... FDh = 99.2% FEh = 99.6% FFh = 100%

2.13.24 LED_2_AEU3_T12 Register (Offset = CBh) [Reset = 00h]

LED_2_AEU3_T12 is shown in [Figure 2-110](#) and described in [Table 2-123](#).

Return to the [Summary Table](#).

Figure 2-110. LED_2_AEU3_T12 Register

7	6	5	4	3	2	1	0
led_2_aeu3_t2				led_2_aeu3_t1			
R/W-0h				R/W-0h			

Table 2-123. LED_2_AEU3_T12 Register Field Descriptions

Bit	Field	Type	Reset	Description
7-4	led_2_aeu3_t2	R/W	0h	AEU3_T2 slope time setting of LED_2 0h = no pause time 1h = 0.09s 2h = 0.18s 3h = 0.36s 4h = 0.54s 5h = 0.80s 6h = 1.07s 7h = 1.52s 8h = 2.06s 9h = 2.50s Ah = 3.04s Bh = 4.02s Ch = 5.01s Dh = 5.99s Eh = 7.06s Fh = 8.05s

Table 2-123. LED_2_AEU3_T12 Register Field Descriptions (continued)

Bit	Field	Type	Reset	Description
3-0	led_2_aeu3_t1	R/W	0h	AEU3_T1 slope time setting of LED_2 0h = no pause time 1h = 0.09s 2h = 0.18s 3h = 0.36s 4h = 0.54s 5h = 0.80s 6h = 1.07s 7h = 1.52s 8h = 2.06s 9h = 2.50s Ah = 3.04s Bh = 4.02s Ch = 5.01s Dh = 5.99s Eh = 7.06s Fh = 8.05s

2.13.25 LED_2_AEU3_T34 Register (Offset = CCh) [Reset = 00h]

LED_2_AEU3_T34 is shown in [Figure 2-111](#) and described in [Table 2-124](#).

Return to the [Summary Table](#).

Figure 2-111. LED_2_AEU3_T34 Register

7	6	5	4	3	2	1	0
led_2_aeu3_t4				led_2_aeu3_t3			
R/W-0h				R/W-0h			

Table 2-124. LED_2_AEU3_T34 Register Field Descriptions

Bit	Field	Type	Reset	Description
7-4	led_2_aeu3_t4	R/W	0h	AEU3_T4 slope time setting of LED_2 0h = no pause time 1h = 0.09s 2h = 0.18s 3h = 0.36s 4h = 0.54s 5h = 0.80s 6h = 1.07s 7h = 1.52s 8h = 2.06s 9h = 2.50s Ah = 3.04s Bh = 4.02s Ch = 5.01s Dh = 5.99s Eh = 7.06s Fh = 8.05s

Table 2-124. LED_2_AEU3_T34 Register Field Descriptions (continued)

Bit	Field	Type	Reset	Description
3-0	led_2_aeu3_t3	R/W	0h	AEU3_T3 slope time setting of LED_2 0h = no pause time 1h = 0.09s 2h = 0.18s 3h = 0.36s 4h = 0.54s 5h = 0.80s 6h = 1.07s 7h = 1.52s 8h = 2.06s 9h = 2.50s Ah = 3.04s Bh = 4.02s Ch = 5.01s Dh = 5.99s Eh = 7.06s Fh = 8.05s

2.13.26 LED_2_AEU3_Playback Register (Offset = CDh) [Reset = 00h]

LED_2_AEU3_Playback is shown in [Figure 2-112](#) and described in [Table 2-125](#).

Return to the [Summary Table](#).

Figure 2-112. LED_2_AEU3_Playback Register

7	6	5	4	3	2	1	0
RESERVED						led_2_aeu3_pt	
R-0h						R/W-0h	

Table 2-125. LED_2_AEU3_Playback Register Field Descriptions

Bit	Field	Type	Reset	Description
7-2	RESERVED	R	0h	Reserved
1-0	led_2_aeu3_pt	R/W	0h	AEU3 pattern playback times of LED_2 0h = 0 time 1h = 1 time 2h = 2 times 3h = Infinite times

2.14 LED_3_Autonomous_Animation Registers

Table 2-126 lists the memory-mapped registers for the LED_3_Autonomous_Animation registers. All register offset addresses not listed in Table 2-126 should be considered as reserved locations and the register contents should not be modified.

Table 2-126. LED_3_AUTONOMOUS_ANIMATION Registers

Offset	Acronym	Register Name	Section
CEh	LED_3_Auto_Pause	Animation pause time at the start and the end of LED_3	Go
CFh	LED_3_Auto_Playback	Animation pattern playback times of LED_3 and active AEU number setting	Go
D0h	LED_3_AEU1_PWM_1	PWM setting of LED_3 AEU1_PWM1	Go
D1h	LED_3_AEU1_PWM_2	PWM setting of LED_3 AEU1_PWM2	Go
D2h	LED_3_AEU1_PWM_3	PWM setting of LED_3 AEU1_PWM3	Go
D3h	LED_3_AEU1_PWM_4	PWM setting of LED_3 AEU1_PWM4	Go
D4h	LED_3_AEU1_PWM_5	PWM setting of LED_3 AEU1_PWM5	Go
D5h	LED_3_AEU1_T12	Slope time setting of LED_3 AEU1_T1 and AEU1_T2	Go
D6h	LED_3_AEU1_T34	Slope time setting of LED_3 AEU1_T3 and AEU1_T4	Go
D7h	LED_3_AEU1_Playback	AEU1 pattern playback times of LED_3	Go
D8h	LED_3_AEU2_PWM_1	PWM setting of LED_3 AEU2_PWM1	Go
D9h	LED_3_AEU2_PWM_2	PWM setting of LED_3 AEU2_PWM2	Go
DAh	LED_3_AEU2_PWM_3	PWM setting of LED_3 AEU2_PWM3	Go
DBh	LED_3_AEU2_PWM_4	PWM setting of LED_3 AEU2_PWM4	Go
DCh	LED_3_AEU2_PWM_5	PWM setting of LED_3 AEU2_PWM5	Go
DDh	LED_3_AEU2_T12	Slope time setting of LED_3 AEU2_T1 and AEU2_T2	Go
DEh	LED_3_AEU2_T34	Slope time setting of LED_3 AEU2_T3 and AEU2_T4	Go
DFh	LED_3_AEU2_Playback	AEU2 pattern playback times of LED_3	Go
E0h	LED_3_AEU3_PWM_1	PWM setting of LED_3 AEU3_PWM1	Go
E1h	LED_3_AEU3_PWM_2	PWM setting of LED_3 AEU3_PWM2	Go
E2h	LED_3_AEU3_PWM_3	PWM setting of LED_3 AEU3_PWM3	Go
E3h	LED_3_AEU3_PWM_4	PWM setting of LED_3 AEU3_PWM4	Go
E4h	LED_3_AEU3_PWM_5	PWM setting of LED_3 AEU3_PWM5	Go
E5h	LED_3_AEU3_T12	Slope time setting of LED_3 AEU3_T1 and AEU3_T2	Go
E6h	LED_3_AEU3_T34	Slope time setting of LED_3 AEU3_T3 and AEU3_T4	Go
E7h	LED_3_AEU3_Playback	AEU3 pattern playback times of LED_3	Go

2.14.1 LED_3_Auto_Pause Register (Offset = CEh) [Reset = 00h]

LED_3_Auto_Pause is shown in Figure 2-113 and described in Table 2-127.

Return to the [Summary Table](#).

Figure 2-113. LED_3_Auto_Pause Register

7	6	5	4	3	2	1	0
led_3_tp_ts				led_3_tp_te			
R/W-0h				R/W-0h			

Table 2-127. LED_3_Auto_Pause Register Field Descriptions

Bit	Field	Type	Reset	Description
7-4	led_3_tp_ts	R/W	0h	Animation pause time at the start of LED_3 0h = no pause time 1h = 0.09s 2h = 0.18s 3h = 0.36s 4h = 0.54s 5h = 0.80s 6h = 1.07s 7h = 1.52s 8h = 2.06s 9h = 2.50s Ah = 3.04s Bh = 4.02s Ch = 5.01s Dh = 5.99s Eh = 7.06s Fh = 8.05s
3-0	led_3_tp_te	R/W	0h	Animation pause time at the end of LED_3 0h = no pause time 1h = 0.09s 2h = 0.18s 3h = 0.36s 4h = 0.54s 5h = 0.80s 6h = 1.07s 7h = 1.52s 8h = 2.06s 9h = 2.50s Ah = 3.04s Bh = 4.02s Ch = 5.01s Dh = 5.99s Eh = 7.06s Fh = 8.05s

2.14.2 LED_3_Auto_Playback Register (Offset = CFh) [Reset = 00h]

LED_3_Auto_Playback is shown in [Figure 2-114](#) and described in [Table 2-128](#).

Return to the [Summary Table](#).

Figure 2-114. LED_3_Auto_Playback Register

7	6	5	4	3	2	1	0
RESERVED		led_3_aeu_num		led_3_pt			
R-0h		R/W-0h		R/W-0h			

Table 2-128. LED_3_Auto_Playback Register Field Descriptions

Bit	Field	Type	Reset	Description
7-6	RESERVED	R	0h	Reserved
5-4	led_3_aeu_num	R/W	0h	Active AEU number of LED_3 selection 0h = only use AEU1 1h = use AEU1 and AEU2 2h = use AEU1, AEU2 and AEU3 3h = use AEU1, AEU2 and AEU3 (the same as 2h)

Table 2-128. LED_3_Auto_Playback Register Field Descriptions (continued)

Bit	Field	Type	Reset	Description
3-0	led_3_pt	R/W	0h	Animation pattern playback times of LED_3 0h = 0 times 1h = 1 times 2h = 2 times 3h = 3 times 4h = 4 times 5h = 5 times 6h = 6 times 7h = 7 times 8h = 8 times 9h = 9 times Ah = 10 times Bh = 11 times Ch = 12 times Dh = 13 times Eh = 14 times Fh = infinite times

2.14.3 LED_3_AEU1_PWM_1 Register (Offset = D0h) [Reset = 00h]

LED_3_AEU1_PWM_1 is shown in [Figure 2-115](#) and described in [Table 2-129](#).

Return to the [Summary Table](#).

Figure 2-115. LED_3_AEU1_PWM_1 Register

7	6	5	4	3	2	1	0
led_3_aeu1_pwm1							
R/W-0h							

Table 2-129. LED_3_AEU1_PWM_1 Register Field Descriptions

Bit	Field	Type	Reset	Description
7-0	led_3_aeu1_pwm1	R/W	0h	AEU1_PWM1 setting of LED_3 0h = 0 1h = 0.39% 2h = 0.78% ... 80h = 50.2% ... FDh = 99.2% FEh = 99.6% FFh = 100%

2.14.4 LED_3_AEU1_PWM_2 Register (Offset = D1h) [Reset = 00h]

LED_3_AEU1_PWM_2 is shown in [Figure 2-116](#) and described in [Table 2-130](#).

Return to the [Summary Table](#).

Figure 2-116. LED_3_AEU1_PWM_2 Register

7	6	5	4	3	2	1	0
led_3_aeu1_pwm2							
R/W-0h							

Table 2-130. LED_3_AEU1_PWM_2 Register Field Descriptions

Bit	Field	Type	Reset	Description
7-0	led_3_aeu1_pwm2	R/W	0h	AEU1_PWM2 setting of LED_3 0h = 0 1h = 0.39% 2h = 0.78% ... 80h = 50.2% ... FDh = 99.2% FEh = 99.6% FFh = 100%

2.14.5 LED_3_AEU1_PWM_3 Register (Offset = D2h) [Reset = 00h]

LED_3_AEU1_PWM_3 is shown in [Figure 2-117](#) and described in [Table 2-131](#).

Return to the [Summary Table](#).

Figure 2-117. LED_3_AEU1_PWM_3 Register

7	6	5	4	3	2	1	0
led_3_aeu1_pwm3							
R/W-0h							

Table 2-131. LED_3_AEU1_PWM_3 Register Field Descriptions

Bit	Field	Type	Reset	Description
7-0	led_3_aeu1_pwm3	R/W	0h	AEU1_PWM3 setting of LED_3 0h = 0 1h = 0.39% 2h = 0.78% ... 80h = 50.2% ... FDh = 99.2% FEh = 99.6% FFh = 100%

2.14.6 LED_3_AEU1_PWM_4 Register (Offset = D3h) [Reset = 00h]

LED_3_AEU1_PWM_4 is shown in [Figure 2-118](#) and described in [Table 2-132](#).

Return to the [Summary Table](#).

Figure 2-118. LED_3_AEU1_PWM_4 Register

7	6	5	4	3	2	1	0
led_3_aeu1_pwm4							
R/W-0h							

Table 2-132. LED_3_AEU1_PWM_4 Register Field Descriptions

Bit	Field	Type	Reset	Description
7-0	led_3_aeu1_pwm4	R/W	0h	AEU1_PWM4 setting of LED_3 0h = 0 1h = 0.39% 2h = 0.78% ... 80h = 50.2% ... FDh = 99.2% FEh = 99.6% FFh = 100%

2.14.7 LED_3_AEU1_PWM_5 Register (Offset = D4h) [Reset = 00h]

LED_3_AEU1_PWM_5 is shown in [Figure 2-119](#) and described in [Table 2-133](#).

Return to the [Summary Table](#).

Figure 2-119. LED_3_AEU1_PWM_5 Register

7	6	5	4	3	2	1	0
led_3_aeu1_pwm5							
R/W-0h							

Table 2-133. LED_3_AEU1_PWM_5 Register Field Descriptions

Bit	Field	Type	Reset	Description
7-0	led_3_aeu1_pwm5	R/W	0h	AEU1_PWM5 setting of LED_3 0h = 0 1h = 0.39% 2h = 0.78% ... 80h = 50.2% ... FDh = 99.2% FEh = 99.6% FFh = 100%

2.14.8 LED_3_AEU1_T12 Register (Offset = D5h) [Reset = 00h]

LED_3_AEU1_T12 is shown in [Figure 2-120](#) and described in [Table 2-134](#).

Return to the [Summary Table](#).

Figure 2-120. LED_3_AEU1_T12 Register

7	6	5	4	3	2	1	0
led_3_aeu1_t2				led_3_aeu1_t1			
R/W-0h				R/W-0h			

Table 2-134. LED_3_AEU1_T12 Register Field Descriptions

Bit	Field	Type	Reset	Description
7-4	led_3_aeu1_t2	R/W	0h	AEU1_T2 slope time setting of LED_3 0h = no pause time 1h = 0.09s 2h = 0.18s 3h = 0.36s 4h = 0.54s 5h = 0.80s 6h = 1.07s 7h = 1.52s 8h = 2.06s 9h = 2.50s Ah = 3.04s Bh = 4.02s Ch = 5.01s Dh = 5.99s Eh = 7.06s Fh = 8.05s
3-0	led_3_aeu1_t1	R/W	0h	AEU1_T1 slope time setting of LED_3 0h = no pause time 1h = 0.09s 2h = 0.18s 3h = 0.36s 4h = 0.54s 5h = 0.80s 6h = 1.07s 7h = 1.52s 8h = 2.06s 9h = 2.50s Ah = 3.04s Bh = 4.02s Ch = 5.01s Dh = 5.99s Eh = 7.06s Fh = 8.05s

2.14.9 LED_3_AEU1_T34 Register (Offset = D6h) [Reset = 00h]

LED_3_AEU1_T34 is shown in [Figure 2-121](#) and described in [Table 2-135](#).

Return to the [Summary Table](#).

Figure 2-121. LED_3_AEU1_T34 Register

7	6	5	4	3	2	1	0
led_3_aeu1_t4				led_3_aeu1_t3			
R/W-0h				R/W-0h			

Table 2-135. LED_3_AEU1_T34 Register Field Descriptions

Bit	Field	Type	Reset	Description
7-4	led_3_aeu1_t4	R/W	0h	AEU1_T4 slope time setting of LED_3 0h = no pause time 1h = 0.09s 2h = 0.18s 3h = 0.36s 4h = 0.54s 5h = 0.80s 6h = 1.07s 7h = 1.52s 8h = 2.06s 9h = 2.50s Ah = 3.04s Bh = 4.02s Ch = 5.01s Dh = 5.99s Eh = 7.06s Fh = 8.05s
3-0	led_3_aeu1_t3	R/W	0h	AEU1_T3 slope time setting of LED_3 0h = no pause time 1h = 0.09s 2h = 0.18s 3h = 0.36s 4h = 0.54s 5h = 0.80s 6h = 1.07s 7h = 1.52s 8h = 2.06s 9h = 2.50s Ah = 3.04s Bh = 4.02s Ch = 5.01s Dh = 5.99s Eh = 7.06s Fh = 8.05s

2.14.10 LED_3_AEU1_Playback Register (Offset = D7h) [Reset = 00h]

LED_3_AEU1_Playback is shown in [Figure 2-122](#) and described in [Table 2-136](#).

Return to the [Summary Table](#).

Figure 2-122. LED_3_AEU1_Playback Register

7	6	5	4	3	2	1	0
RESERVED						led_3_aeu1_pt	
R-0h						R/W-0h	

Table 2-136. LED_3_AEU1_Playback Register Field Descriptions

Bit	Field	Type	Reset	Description
7-2	RESERVED	R	0h	Reserved
1-0	led_3_aeu1_pt	R/W	0h	AEU1 pattern playback times of LED_3 0h = 0 time 1h = 1 time 2h = 2 times 3h = Infinite times

2.14.11 LED_3_AEU2_PWM_1 Register (Offset = D8h) [Reset = 00h]

LED_3_AEU2_PWM_1 is shown in [Figure 2-123](#) and described in [Table 2-137](#).

Return to the [Summary Table](#).

Figure 2-123. LED_3_AEU2_PWM_1 Register

7	6	5	4	3	2	1	0
led_3_aeu2_pwm1							
R/W-0h							

Table 2-137. LED_3_AEU2_PWM_1 Register Field Descriptions

Bit	Field	Type	Reset	Description
7-0	led_3_aeu2_pwm1	R/W	0h	AEU2_PWM1 setting of LED_3 0h = 0 1h = 0.39% 2h = 0.78% ... 80h = 50.2% ... FDh = 99.2% FEh = 99.6% FFh = 100%

2.14.12 LED_3_AEU2_PWM_2 Register (Offset = D9h) [Reset = 00h]

LED_3_AEU2_PWM_2 is shown in [Figure 2-124](#) and described in [Table 2-138](#).

Return to the [Summary Table](#).

Figure 2-124. LED_3_AEU2_PWM_2 Register

7	6	5	4	3	2	1	0
led_3_aeu2_pwm2							
R/W-0h							

Table 2-138. LED_3_AEU2_PWM_2 Register Field Descriptions

Bit	Field	Type	Reset	Description
7-0	led_3_aeu2_pwm2	R/W	0h	AEU2_PWM2 setting of LED_3 0h = 0 1h = 0.39% 2h = 0.78% ... 80h = 50.2% ... FDh = 99.2% FEh = 99.6% FFh = 100%

2.14.13 LED_3_AEU2_PWM_3 Register (Offset = DAh) [Reset = 00h]

LED_3_AEU2_PWM_3 is shown in [Figure 2-125](#) and described in [Table 2-139](#).

Return to the [Summary Table](#).

Figure 2-125. LED_3_AEU2_PWM_3 Register

7	6	5	4	3	2	1	0
led_3_aeu2_pwm3							
R/W-0h							

Table 2-139. LED_3_AEU2_PWM_3 Register Field Descriptions

Bit	Field	Type	Reset	Description
7-0	led_3_aeu2_pwm3	R/W	0h	AEU2_PWM3 setting of LED_3 0h = 0 1h = 0.39% 2h = 0.78% ... 80h = 50.2% ... FDh = 99.2% FEh = 99.6% FFh = 100%

2.14.14 LED_3_AEU2_PWM_4 Register (Offset = DBh) [Reset = 00h]

LED_3_AEU2_PWM_4 is shown in [Figure 2-126](#) and described in [Table 2-140](#).

Return to the [Summary Table](#).

Figure 2-126. LED_3_AEU2_PWM_4 Register

7	6	5	4	3	2	1	0
led_3_aeu2_pwm4							
R/W-0h							

Table 2-140. LED_3_AEU2_PWM_4 Register Field Descriptions

Bit	Field	Type	Reset	Description
7-0	led_3_aeu2_pwm4	R/W	0h	AEU2_PWM4 setting of LED_3 0h = 0 1h = 0.39% 2h = 0.78% ... 80h = 50.2% ... FDh = 99.2% FEh = 99.6% FFh = 100%

2.14.15 LED_3_AEU2_PWM_5 Register (Offset = DCh) [Reset = 00h]

LED_3_AEU2_PWM_5 is shown in [Figure 2-127](#) and described in [Table 2-141](#).

Return to the [Summary Table](#).

Figure 2-127. LED_3_AEU2_PWM_5 Register

7	6	5	4	3	2	1	0
led_3_aeu2_pwm5							
R/W-0h							

Table 2-141. LED_3_AEU2_PWM_5 Register Field Descriptions

Bit	Field	Type	Reset	Description
7-0	led_3_aeu2_pwm5	R/W	0h	AEU2_PWM5 setting of LED_3 0h = 0 1h = 0.39% 2h = 0.78% ... 80h = 50.2% ... FDh = 99.2% FEh = 99.6% FFh = 100%

2.14.16 LED_3_AEU2_T12 Register (Offset = DDh) [Reset = 00h]

 LED_3_AEU2_T12 is shown in [Figure 2-128](#) and described in [Table 2-142](#).

 Return to the [Summary Table](#).

Figure 2-128. LED_3_AEU2_T12 Register

7	6	5	4	3	2	1	0
led_3_aeu2_t2				led_3_aeu2_t1			
R/W-0h				R/W-0h			

Table 2-142. LED_3_AEU2_T12 Register Field Descriptions

Bit	Field	Type	Reset	Description
7-4	led_3_aeu2_t2	R/W	0h	AEU2_T2 slope time setting of LED_3 0h = no pause time 1h = 0.09s 2h = 0.18s 3h = 0.36s 4h = 0.54s 5h = 0.80s 6h = 1.07s 7h = 1.52s 8h = 2.06s 9h = 2.50s Ah = 3.04s Bh = 4.02s Ch = 5.01s Dh = 5.99s Eh = 7.06s Fh = 8.05s
3-0	led_3_aeu2_t1	R/W	0h	AEU2_T1 slope time setting of LED_3 0h = no pause time 1h = 0.09s 2h = 0.18s 3h = 0.36s 4h = 0.54s 5h = 0.80s 6h = 1.07s 7h = 1.52s 8h = 2.06s 9h = 2.50s Ah = 3.04s Bh = 4.02s Ch = 5.01s Dh = 5.99s Eh = 7.06s Fh = 8.05s

2.14.17 LED_3_AEU2_T34 Register (Offset = DEh) [Reset = 00h]

LED_3_AEU2_T34 is shown in [Figure 2-129](#) and described in [Table 2-143](#).

Return to the [Summary Table](#).

Figure 2-129. LED_3_AEU2_T34 Register

7	6	5	4	3	2	1	0
led_3_aeu2_t4				led_3_aeu2_t3			
R/W-0h				R/W-0h			

Table 2-143. LED_3_AEU2_T34 Register Field Descriptions

Bit	Field	Type	Reset	Description
7-4	led_3_aeu2_t4	R/W	0h	AEU2_T4 slope time setting of LED_3 0h = no pause time 1h = 0.09s 2h = 0.18s 3h = 0.36s 4h = 0.54s 5h = 0.80s 6h = 1.07s 7h = 1.52s 8h = 2.06s 9h = 2.50s Ah = 3.04s Bh = 4.02s Ch = 5.01s Dh = 5.99s Eh = 7.06s Fh = 8.05s
3-0	led_3_aeu2_t3	R/W	0h	AEU2_T3 slope time setting of LED_3 0h = no pause time 1h = 0.09s 2h = 0.18s 3h = 0.36s 4h = 0.54s 5h = 0.80s 6h = 1.07s 7h = 1.52s 8h = 2.06s 9h = 2.50s Ah = 3.04s Bh = 4.02s Ch = 5.01s Dh = 5.99s Eh = 7.06s Fh = 8.05s

2.14.18 LED_3_AEU2_Playback Register (Offset = DFh) [Reset = 00h]

LED_3_AEU2_Playback is shown in [Figure 2-130](#) and described in [Table 2-144](#).

Return to the [Summary Table](#).

Figure 2-130. LED_3_AEU2_Playback Register

7	6	5	4	3	2	1	0
RESERVED						led_3_aeu2_pt	
R-0h						R/W-0h	

Table 2-144. LED_3_AEU2_Playback Register Field Descriptions

Bit	Field	Type	Reset	Description
7-2	RESERVED	R	0h	Reserved
1-0	led_3_aeu2_pt	R/W	0h	AEU2 pattern playback times of LED_3 0h = 0 time 1h = 1 time 2h = 2 times 3h = Infinite times

2.14.19 LED_3_AEU3_PWM_1 Register (Offset = E0h) [Reset = 00h]

 LED_3_AEU3_PWM_1 is shown in [Figure 2-131](#) and described in [Table 2-145](#).

 Return to the [Summary Table](#).

Figure 2-131. LED_3_AEU3_PWM_1 Register

7	6	5	4	3	2	1	0
led_3_aeu3_pwm1							
R/W-0h							

Table 2-145. LED_3_AEU3_PWM_1 Register Field Descriptions

Bit	Field	Type	Reset	Description
7-0	led_3_aeu3_pwm1	R/W	0h	AEU3_PWM1 setting of LED_3 0h = 0 1h = 0.39% 2h = 0.78% ... 80h = 50.2% ... FDh = 99.2% FEh = 99.6% FFh = 100%

2.14.20 LED_3_AEU3_PWM_2 Register (Offset = E1h) [Reset = 00h]

 LED_3_AEU3_PWM_2 is shown in [Figure 2-132](#) and described in [Table 2-146](#).

 Return to the [Summary Table](#).

Figure 2-132. LED_3_AEU3_PWM_2 Register

7	6	5	4	3	2	1	0
led_3_aeu3_pwm2							
R/W-0h							

Table 2-146. LED_3_AEU3_PWM_2 Register Field Descriptions

Bit	Field	Type	Reset	Description
7-0	led_3_aeu3_pwm2	R/W	0h	AEU3_PWM2 setting of LED_3 0h = 0 1h = 0.39% 2h = 0.78% ... 80h = 50.2% ... FDh = 99.2% FEh = 99.6% FFh = 100%

2.14.21 LED_3_AEU3_PWM_3 Register (Offset = E2h) [Reset = 00h]

LED_3_AEU3_PWM_3 is shown in [Figure 2-133](#) and described in [Table 2-147](#).

Return to the [Summary Table](#).

Figure 2-133. LED_3_AEU3_PWM_3 Register

7	6	5	4	3	2	1	0
led_3_aeu3_pwm3							
R/W-0h							

Table 2-147. LED_3_AEU3_PWM_3 Register Field Descriptions

Bit	Field	Type	Reset	Description
7-0	led_3_aeu3_pwm3	R/W	0h	AEU3_PWM3 setting of LED_3 0h = 0 1h = 0.39% 2h = 0.78% ... 80h = 50.2% ... FDh = 99.2% FEh = 99.6% FFh = 100%

2.14.22 LED_3_AEU3_PWM_4 Register (Offset = E3h) [Reset = 00h]

LED_3_AEU3_PWM_4 is shown in [Figure 2-134](#) and described in [Table 2-148](#).

Return to the [Summary Table](#).

Figure 2-134. LED_3_AEU3_PWM_4 Register

7	6	5	4	3	2	1	0
led_3_aeu3_pwm4							
R/W-0h							

Table 2-148. LED_3_AEU3_PWM_4 Register Field Descriptions

Bit	Field	Type	Reset	Description
7-0	led_3_aeu3_pwm4	R/W	0h	AEU3_PWM4 setting of LED_3 0h = 0 1h = 0.39% 2h = 0.78% ... 80h = 50.2% ... FDh = 99.2% FEh = 99.6% FFh = 100%

2.14.23 LED_3_AEU3_PWM_5 Register (Offset = E4h) [Reset = 00h]

LED_3_AEU3_PWM_5 is shown in [Figure 2-135](#) and described in [Table 2-149](#).

Return to the [Summary Table](#).

Figure 2-135. LED_3_AEU3_PWM_5 Register

7	6	5	4	3	2	1	0
led_3_aeu3_pwm5							
R/W-0h							

Figure 2-135. LED_3_AEU3_PWM_5 Register (continued)
Table 2-149. LED_3_AEU3_PWM_5 Register Field Descriptions

Bit	Field	Type	Reset	Description
7-0	led_3_aeu3_pwm5	R/W	0h	AEU3_PWM5 setting of LED_3 0h = 0 1h = 0.39% 2h = 0.78% ... 80h = 50.2% ... FDh = 99.2% FEh = 99.6% FFh = 100%

2.14.24 LED_3_AEU3_T12 Register (Offset = E5h) [Reset = 00h]

LED_3_AEU3_T12 is shown in [Figure 2-136](#) and described in [Table 2-150](#).

Return to the [Summary Table](#).

Figure 2-136. LED_3_AEU3_T12 Register

7	6	5	4	3	2	1	0
led_3_aeu3_t2				led_3_aeu3_t1			
R/W-0h				R/W-0h			

Table 2-150. LED_3_AEU3_T12 Register Field Descriptions

Bit	Field	Type	Reset	Description
7-4	led_3_aeu3_t2	R/W	0h	AEU3_T2 slope time setting of LED_3 0h = no pause time 1h = 0.09s 2h = 0.18s 3h = 0.36s 4h = 0.54s 5h = 0.80s 6h = 1.07s 7h = 1.52s 8h = 2.06s 9h = 2.50s Ah = 3.04s Bh = 4.02s Ch = 5.01s Dh = 5.99s Eh = 7.06s Fh = 8.05s

Table 2-150. LED_3_AEU3_T12 Register Field Descriptions (continued)

Bit	Field	Type	Reset	Description
3-0	led_3_aeu3_t1	R/W	0h	AEU3_T1 slope time setting of LED_3 0h = no pause time 1h = 0.09s 2h = 0.18s 3h = 0.36s 4h = 0.54s 5h = 0.80s 6h = 1.07s 7h = 1.52s 8h = 2.06s 9h = 2.50s Ah = 3.04s Bh = 4.02s Ch = 5.01s Dh = 5.99s Eh = 7.06s Fh = 8.05s

2.14.25 LED_3_AEU3_T34 Register (Offset = E6h) [Reset = 00h]

LED_3_AEU3_T34 is shown in [Figure 2-137](#) and described in [Table 2-151](#).

Return to the [Summary Table](#).

Figure 2-137. LED_3_AEU3_T34 Register

7	6	5	4	3	2	1	0
led_3_aeu3_t4				led_3_aeu3_t3			
R/W-0h				R/W-0h			

Table 2-151. LED_3_AEU3_T34 Register Field Descriptions

Bit	Field	Type	Reset	Description
7-4	led_3_aeu3_t4	R/W	0h	AEU3_T4 slope time setting of LED_3 0h = no pause time 1h = 0.09s 2h = 0.18s 3h = 0.36s 4h = 0.54s 5h = 0.80s 6h = 1.07s 7h = 1.52s 8h = 2.06s 9h = 2.50s Ah = 3.04s Bh = 4.02s Ch = 5.01s Dh = 5.99s Eh = 7.06s Fh = 8.05s

Table 2-151. LED_3_AEU3_T34 Register Field Descriptions (continued)

Bit	Field	Type	Reset	Description
3-0	led_3_aeu3_t3	R/W	0h	AEU3_T3 slope time setting of LED_3 0h = no pause time 1h = 0.09s 2h = 0.18s 3h = 0.36s 4h = 0.54s 5h = 0.80s 6h = 1.07s 7h = 1.52s 8h = 2.06s 9h = 2.50s Ah = 3.04s Bh = 4.02s Ch = 5.01s Dh = 5.99s Eh = 7.06s Fh = 8.05s

2.14.26 LED_3_AEU3_Playback Register (Offset = E7h) [Reset = 00h]

LED_3_AEU3_Playback is shown in [Figure 2-138](#) and described in [Table 2-152](#).

Return to the [Summary Table](#).

Figure 2-138. LED_3_AEU3_Playback Register

7	6	5	4	3	2	1	0
RESERVED						led_3_aeu3_pt	
R-0h						R/W-0h	

Table 2-152. LED_3_AEU3_Playback Register Field Descriptions

Bit	Field	Type	Reset	Description
7-2	RESERVED	R	0h	Reserved
1-0	led_3_aeu3_pt	R/W	0h	AEU3 pattern playback times of LED_3 0h = 0 time 1h = 1 time 2h = 2 times 3h = Infinite times

2.15 Flag Registers

Table 2-153 lists the memory-mapped registers for the Flag registers. All register offset addresses not listed in Table 2-153 should be considered as reserved locations and the register contents should not be modified.

Table 2-153. FLAG Registers

Offset	Acronym	Register Name	Section
300h	TSD_Config_Status	Configuration fault and TSD flags	Go
301h	LOD_Status_0	LOD flags of LED_0 to LED_3	Go
302h	LOD_Status_1	Reserved	
303h	LSD_Status_0	LSD flags of LED_0 to LED_3	Go
304h	LSD_Status_1	Reserved	
305h	Auto_PWM_0	PWM value in autonomous mode of LED_0	Go
306h	Auto_PWM_1	PWM value in autonomous mode of LED_1	Go
307h	Auto_PWM_2	PWM value in autonomous mode of LED_2	Go
308h	Auto_PWM_3	PWM value in autonomous mode of LED_3	Go
315h	AEP_Status_0	Autonomous engine pattern status of LED_0 and LED_1	Go
316h	AEP_Status_1	Autonomous engine pattern status of LED_2 and LED_3	Go

2.15.1 TSD_Config_Status Register (Offset = 300h) [Reset = 00h]

TSD_Config_Status is shown in Figure 2-139 and described in Table 2-154.

Return to the [Summary Table](#).

Figure 2-139. TSD_Config_Status Register

7	6	5	4	3	2	1	0
RESERVED						tsd_status	config_err_status
R-0h						R-0h	R-0h

Table 2-154. TSD_Config_Status Register Field Descriptions

Bit	Field	Type	Reset	Description
7-2	RESERVED	R	0h	Reserved
1	tsd_status	R	0h	Boost/Linear TSD fault flag 0h = Boost/Linear TSD are not detected 1h = Boost/Linear TSD are detected
0	config_err_status	R	0h	Configuration fault flag 0h = LED_CONFIG and SCAN_ORDERx registers are properly set 1h = LED_CONFIG and SCAN_ORDERx registers are improperly set

2.15.2 LOD_Status_0 Register (Offset = 301h) [Reset = 00h]

LOD_Status_0 is shown in Figure 2-140 and described in Table 2-155.

Return to the [Summary Table](#).

Figure 2-140. LOD_Status_0 Register

7	6	5	4	3	2	1	0
RESERVED				lod_status_3	lod_status_2	lod_status_1	lod_status_0
R-0h				R-0h	R-0h	R-0h	R-0h

Table 2-155. LOD_Status_0 Register Field Descriptions

Bit	Field	Type	Reset	Description
7-4	RESERVED	R	0h	Reserved
3	lod_status_3	R	0h	LED_3 LOD status flag 0h = LOD fault is not detected 1h = LOD fault is detected
2	lod_status_2	R	0h	LED_2 LOD status flag 0h = LOD fault is not detected 1h = LOD fault is detected
1	lod_status_1	R	0h	LED_1 LOD status flag 0h = LOD fault is not detected 1h = LOD fault is detected
0	lod_status_0	R	0h	LED_0 LOD status flag 0h = LOD fault is not detected 1h = LOD fault is detected

2.15.3 LOD_Status_1 Register (Offset = 302h) [Reset = 00h]

LOD_Status_1 is shown in [Figure 2-141](#) and described in [Table 2-156](#).

Return to the [Summary Table](#).

Figure 2-141. LOD_Status_1 Register

7	6	5	4	3	2	1	0
RESERVED							
R-0h							

Table 2-156. LOD_Status_1 Register Field Descriptions

Bit	Field	Type	Reset	Description
7-0	RESERVED	R	0h	Reserved

2.15.4 LSD_Status_0 Register (Offset = 303h) [Reset = 00h]

LSD_Status_0 is shown in [Figure 2-142](#) and described in [Table 2-157](#).

Return to the [Summary Table](#).

Figure 2-142. LSD_Status_0 Register

7	6	5	4	3	2	1	0
RESERVED				lsd_status_3	lsd_status_2	lsd_status_1	lsd_status_0
R-0h				R-0h	R-0h	R-0h	R-0h

Table 2-157. LSD_Status_0 Register Field Descriptions

Bit	Field	Type	Reset	Description
7-4	RESERVED	R	0h	Reserved
3	lsd_status_3	R	0h	LED_3 LSD status flag 0h = LSD fault is not detected 1h = LSD fault is detected
2	lsd_status_2	R	0h	LED_2 LSD status flag 0h = LSD fault is not detected 1h = LSD fault is detected
1	lsd_status_1	R	0h	LED_1 LSD status flag 0h = LSD fault is not detected 1h = LSD fault is detected

Table 2-157. LSD_Status_0 Register Field Descriptions (continued)

Bit	Field	Type	Reset	Description
0	lsd_status_0	R	0h	LED_0 LSD status flag 0h = LSD fault is not detected 1h = LSD fault is detected

2.15.5 LSD_Status_1 Register (Offset = 304h) [Reset = 00h]

LSD_Status_1 is shown in [Figure 2-143](#) and described in [Table 2-158](#).

Return to the [Summary Table](#).

Figure 2-143. LSD_Status_1 Register

7	6	5	4	3	2	1	0
RESERVED							
R-0h							

Table 2-158. LSD_Status_1 Register Field Descriptions

Bit	Field	Type	Reset	Description
7-0	RESERVED	R	0h	Reserved

2.15.6 Auto_PWM_0 Register (Offset = 305h) [Reset = 00h]

Auto_PWM_0 is shown in [Figure 2-144](#) and described in [Table 2-159](#).

Return to the [Summary Table](#).

Figure 2-144. Auto_PWM_0 Register

7	6	5	4	3	2	1	0
pwm_auto_0							
R-0h							

Table 2-159. Auto_PWM_0 Register Field Descriptions

Bit	Field	Type	Reset	Description
7-0	pwm_auto_0	R	0h	PWM value in autonomous mode of LED_0, precise when pause the animation

2.15.7 Auto_PWM_1 Register (Offset = 306h) [Reset = 00h]

Auto_PWM_1 is shown in [Figure 2-145](#) and described in [Table 2-160](#).

Return to the [Summary Table](#).

Figure 2-145. Auto_PWM_1 Register

7	6	5	4	3	2	1	0
pwm_auto_1							
R-0h							

Table 2-160. Auto_PWM_1 Register Field Descriptions

Bit	Field	Type	Reset	Description
7-0	pwm_auto_1	R	0h	PWM value in autonomous mode of LED_1, precise when pause the animation

2.15.8 Auto_PWM_2 Register (Offset = 307h) [Reset = 00h]

Auto_PWM_2 is shown in [Figure 2-146](#) and described in [Table 2-161](#).

Return to the [Summary Table](#).

Figure 2-146. Auto_PWM_2 Register

7	6	5	4	3	2	1	0
pwm_auto_2							
R-0h							

Table 2-161. Auto_PWM_2 Register Field Descriptions

Bit	Field	Type	Reset	Description
7-0	pwm_auto_2	R	0h	PWM value in autonomous mode of LED_2, precise when pause the animation

2.15.9 Auto_PWM_3 Register (Offset = 308h) [Reset = 00h]

Auto_PWM_3 is shown in [Figure 2-147](#) and described in [Table 2-162](#).

Return to the [Summary Table](#).

Figure 2-147. Auto_PWM_3 Register

7	6	5	4	3	2	1	0
pwm_auto_3							
R-0h							

Table 2-162. Auto_PWM_3 Register Field Descriptions

Bit	Field	Type	Reset	Description
7-0	pwm_auto_3	R	0h	PWM value in autonomous mode of LED_3, precise when pause the animation

2.15.10 AEP_Status_0 Register (Offset = 315h) [Reset = 3Fh]

AEP_Status_0 is shown in [Figure 2-148](#) and described in [Table 2-163](#).

Return to the [Summary Table](#).

Figure 2-148. AEP_Status_0 Register

7	6	5	4	3	2	1	0
RESERVED		aep_status_1			aep_status_0		
R-0h		R-7h			R-7h		

Table 2-163. AEP_Status_0 Register Field Descriptions

Bit	Field	Type	Reset	Description
7-6	RESERVED	R	0h	Reserved
5-3	aep_status_1	R	7h	Autonomous engine pattern status of LED_1 0h = During APU1 1h = During AEU1 2h = During AEU2 3h = During AEU3 4h = During APU2 5/6/7h = Error

Table 2-163. AEP_Status_0 Register Field Descriptions (continued)

Bit	Field	Type	Reset	Description
2-0	aep_status_0	R	7h	Autonomous engine pattern status of LED_0 0h = During APU1 1h = During AEU1 2h = During AEU2 3h = During AEU3 4h = During APU2 5/6/7h = Error

2.15.11 AEP_Status_1 Register (Offset = 316h) [Reset = 3Fh]

AEP_Status_1 is shown in [Figure 2-149](#) and described in [Table 2-164](#).

Return to the [Summary Table](#).

Figure 2-149. AEP_Status_1 Register

7	6	5	4	3	2	1	0
RESERVED		aep_status_3			aep_status_2		
R-0h		R-7h			R-7h		

Table 2-164. AEP_Status_1 Register Field Descriptions

Bit	Field	Type	Reset	Description
7-6	RESERVED	R	0h	Reserved
5-3	aep_status_3	R	7h	Autonomous engine pattern status of LED_3 0h = During APU1 1h = During AEU1 2h = During AEU2 3h = During AEU3 4h = During APU2 5/6/7h = Error
2-0	aep_status_2	R	7h	Autonomous engine pattern status of LED_2 0h = During APU1 1h = During AEU1 2h = During AEU2 3h = During AEU3 4h = During APU2 5/6/7h = Error

Revision History



NOTE: Page numbers for previous revisions may differ from page numbers in the current version.

DATE	REVISION	NOTES
October 2024	*	Initial Release

IMPORTANT NOTICE AND DISCLAIMER

TI PROVIDES TECHNICAL AND RELIABILITY DATA (INCLUDING DATA SHEETS), DESIGN RESOURCES (INCLUDING REFERENCE DESIGNS), APPLICATION OR OTHER DESIGN ADVICE, WEB TOOLS, SAFETY INFORMATION, AND OTHER RESOURCES "AS IS" AND WITH ALL FAULTS, AND DISCLAIMS ALL WARRANTIES, EXPRESS AND IMPLIED, INCLUDING WITHOUT LIMITATION ANY IMPLIED WARRANTIES OF MERCHANTABILITY, FITNESS FOR A PARTICULAR PURPOSE OR NON-INFRINGEMENT OF THIRD PARTY INTELLECTUAL PROPERTY RIGHTS.

These resources are intended for skilled developers designing with TI products. You are solely responsible for (1) selecting the appropriate TI products for your application, (2) designing, validating and testing your application, and (3) ensuring your application meets applicable standards, and any other safety, security, regulatory or other requirements.

These resources are subject to change without notice. TI grants you permission to use these resources only for development of an application that uses the TI products described in the resource. Other reproduction and display of these resources is prohibited. No license is granted to any other TI intellectual property right or to any third party intellectual property right. TI disclaims responsibility for, and you will fully indemnify TI and its representatives against, any claims, damages, costs, losses, and liabilities arising out of your use of these resources.

TI's products are provided subject to [TI's Terms of Sale](#) or other applicable terms available either on [ti.com](https://www.ti.com) or provided in conjunction with such TI products. TI's provision of these resources does not expand or otherwise alter TI's applicable warranties or warranty disclaimers for TI products.

TI objects to and rejects any additional or different terms you may have proposed.

Mailing Address: Texas Instruments, Post Office Box 655303, Dallas, Texas 75265
Copyright © 2024, Texas Instruments Incorporated