

TLV61220A Low-Input Voltage Step-Up Converter in Thin SOT-23 Package

1 Features

- Up to 95% Efficiency at Typical Operating Conditions
- 5.5µA Quiescent Current
- Startup Into Load at 0.7-V Input Voltage
- Operating Input Voltage from 0.7V to 5.5V
- Pass-Through Function during Shutdown
- Minimum Switching Current 200mA
- Protections:
 - Output Overvoltage
 - Overtemperature
 - Input Undervoltage Lockout
- Adjustable Output Voltage from 1.8V to 5.5V
- Small 6-pin Thin SOT-23 Package

2 Applications

- Battery Powered Applications
 - 1 to 3 Cell Alkaline, NiCd or NiMH
 - 1 Cell Li-Ion or Li-Primary
- Solar or Fuel Cell Powered Applications
- Consumer and Portable Medical Products
- Personal Care Products
- White or Status LEDs
- Smartphones

3 Description

The TLV61220A device provides a power-supply solution for products powered by either a single-cell, two-cell, or three-cell alkaline, NiCd or NiMH, or one-cell Li-Ion or Li-polymer battery. Possible output currents depend on the input-to-output voltage ratio. The boost converter is based on a hysteretic controller topology using synchronous rectification to obtain maximum efficiency at minimal quiescent currents. The output voltage of the adjustable version can be programmed by an external resistor divider, or is set internally to a fixed output voltage. The converter can be switched off by a featured enable pin. While being switched off, battery drain is minimized. The device is packaged in a 6-pin thin SOT-23 package (DBV).

Package Information

PART NUMBER	PACKAGE ⁽¹⁾	BODY SIZE (NOM)
TLV61220A	SOT (6)	2.90mm x 1.60mm

(1) For all available packages, see the orderable addendum at the end of the datasheet.

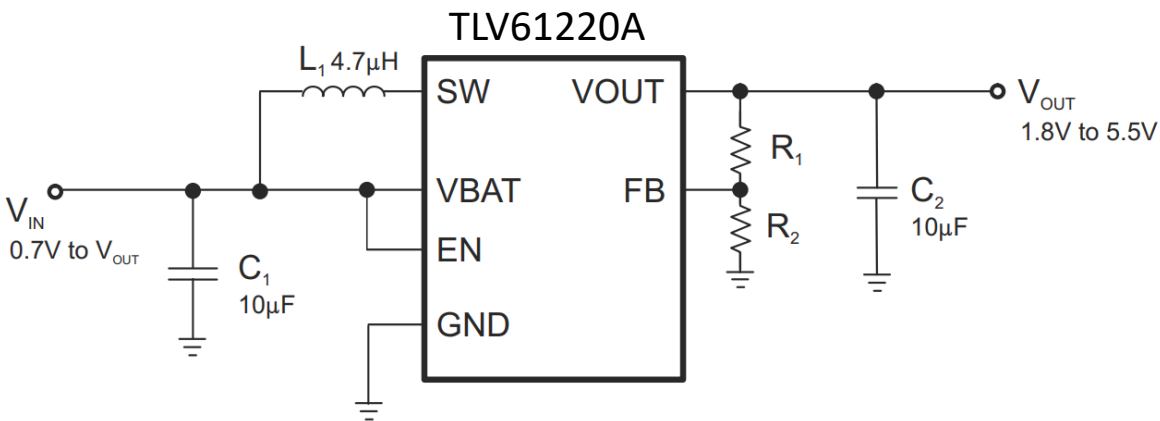

Figure 3-1. Typical application



Table of Contents

1 Features	1	8.4 Device Functional Modes.....	11
2 Applications	1	9 Application and Implementation	12
3 Description	1	9.1 Application Information.....	12
4 Device Comparison	3	9.2 Typical Application.....	12
5 Pin Configuration and Functions	3	10 Power Supply Recommendations	15
Pin Functions.....	3	11 Layout	16
6 Specifications	4	11.1 Layout Guidelines.....	16
6.1 Absolute Maximum Ratings.....	4	11.2 Layout Example.....	16
6.2 ESD Ratings.....	4	11.3 Thermal Considerations.....	16
6.3 Recommended Operating Conditions.....	4	12 Device and Documentation Support	17
6.4 Thermal Information.....	4	12.1 Third-Party Products Disclaimer.....	17
6.5 Electrical Characteristics.....	5	12.2 Documentation Support.....	17
6.6 Typical Characteristics.....	6	12.3 Receiving Notification of Documentation Updates..	17
7 Parameter Measurement Information	9	12.4 Support Resources.....	17
8 Detailed Description	10	12.5 Trademarks.....	17
8.1 Overview.....	10	12.6 Electrostatic Discharge Caution.....	17
8.2 Functional Block Diagram.....	10	12.7 Glossary.....	17
8.3 Feature Description.....	10	13 Revision History	17

4 Device Comparison

T _A	OUTPUT VOLTAGE DC/DC	PACKAGE	PART NUMBER
-40°C to 85°C	Adjustable	6-Pin SOT-23	TLV61220ADBV

5 Pin Configuration and Functions

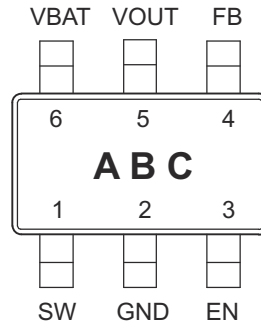

Figure 5-1. DBV Package 6 Pins Top View

Pin Functions

PIN		I/O	DESCRIPTION
NAME	NO.		
EN	3	I	Enable input (VBAT enabled, GND disabled)
FB	4	I	Voltage feedback for programming the output voltage
GND	2	—	IC ground connection for logic and power
SW	1	I	Boost and rectifying switch input
VBAT	6	I	Supply voltage
VOUT	5	O	Boost converter output

6 Specifications

6.1 Absolute Maximum Ratings

over operating free-air temperature range (unless otherwise noted) ⁽¹⁾

		MIN	MAX	UNIT
V _{IN}	Input voltage on VBAT, SW, VOUT, EN, FB	-0.3	7.5	V
T _J	Operating junction temperature	-40	150	°C
T _{stg}	Storage temperature	-65	150	°C

- (1) Stresses beyond those listed under *Absolute Maximum Ratings* may cause permanent damage to the device. These are stress ratings only, which do not imply functional operation of the device at these or any other conditions beyond those indicated under *Recommended Operating Conditions*. Exposure to absolute-maximum-rated conditions for extended periods may affect device reliability.

6.2 ESD Ratings

		VALUE	UNIT
V _(ESD)	Electrostatic discharge	Human-body model (HBM), per ANSI/ESDA/JEDEC JS-001 ⁽¹⁾	±2000
		Charged-device model (CDM), per JEDEC specification JESD22-C101 ⁽²⁾	±1500

- (1) JEDEC document JEP155 states that 500-V HBM allows safe manufacturing with a standard ESD control process.
(2) JEDEC document JEP157 states that 250-V CDM allows safe manufacturing with a standard ESD control process.

6.3 Recommended Operating Conditions

		MIN	NOM	MAX	UNIT
V _{IN}	Supply voltage at VIN	0.7		5.5	V
T _A	Operating free air temperature range	-40		85	°C
T _J	Operating virtual junction temperature range	-40		125	°C

6.4 Thermal Information

	THERMAL METRIC ⁽¹⁾	TLV61220A	UNIT
		DBV	
		6 PINS	
R _{θJA}	Junction-to-ambient thermal resistance	185.7	°C/W
R _{θJC(top)}	Junction-to-case (top) thermal resistance	124.3	
R _{θJB}	Junction-to-board thermal resistance	31.3	
ψ _{JT}	Junction-to-top characterization parameter	22.9	
ψ _{JB}	Junction-to-board characterization parameter	30.8	
R _{θJC(bot)}	Junction-to-case (bottom) thermal resistance	N/A	

- (1) For more information about traditional and new thermal metrics, see the [IC Package Thermal Metrics](#) application report.

6.5 Electrical Characteristics

over recommended free-air temperature range and over recommended input voltage range (typical at an ambient temperature range of 25°C) (unless otherwise noted)

PARAMETER		TEST CONDITIONS	MIN	TYP	MAX	UNIT
DC/DC STAGE						
V_{IN}	Input voltage range		0.7		5.5	V
V_{IN}	Minimum input voltage at startup	$R_{Load} \geq 150\Omega$			0.7	V
V_{OUT}	TLV61220A output voltage range	$V_{IN} < V_{OUT}$	1.8		5.5	V
V_{FB}	TLV61220A feedback voltage		483	500	513	mV
I_{LH}	Inductor current ripple			200		mA
I_{SW}	switch current limit	$V_{OUT} = 3.3V, V_{IN} = 1.2V, T_A = 25^\circ C$	220	400		mA
		$V_{OUT} = 3.3V, T_A = -40^\circ C \text{ to } 85^\circ C$	180	400		mA
		$V_{OUT} = 3.3V, T_A = 0^\circ C \text{ to } 85^\circ C$	200	400		mA
$R_{DS(on)}$	Rectifying switch on resistance, HSD	$V_{OUT} = 3.3V$		1000		m Ω
		$V_{OUT} = 5V$		700		m Ω
	Main switch on resistance, LSD	$V_{OUT} = 3.3V$		600		m Ω
		$V_{OUT} = 5V$		550		m Ω
	Line regulation	$V_{IN} < V_{OUT}$		0.5%		
	Load regulation	$V_{IN} < V_{OUT}$		0.5%		
I_Q	Quiescent current	V_{IN}	$I_O = 0mA, V_{EN} = V_{IN} = 1.2V, V_{OUT} = 3.3V$	0.5	0.9	μA
		V_{OUT}		5	7.5	μA
I_{SD}	Shutdown current	V_{OUT}	$V_{EN} = 0V, V_{IN} = SW = 1.5V, T_A = 25^\circ C$	0.2	7.5	μA
I_{SD}	Shutdown current	V_{OUT}	$V_{EN} = 0V, V_{IN} = SW = 3V, T_A = 25^\circ C$	0.2	7.5	μA
I_{LKG}	Leakage current into VOUT		$V_{EN} = 0V, V_{IN} = 1.2V, V_{OUT} = 3.3V$	1		μA
	Leakage current into SW		$V_{EN} = 0V, V_{IN} = 1.2V, V_{SW} = 1.2V, V_{OUT} \geq V_{IN}$	0.01	0.2	μA
I_{FB}	TLV61220A Feedback input current		$V_{FB} = 0.5V$	0.01		μA
I_{EN}	EN input current		Clamped on GND or $V_{IN} (V_{IN} < 1.5V)$	0.005	0.1	μA
CONTROL STAGE						
V_{IL}	EN input low voltage		$V_{IN} \leq 1.5V$		$0.2 \times V_{IN}$	V
V_{IH}	EN input high voltage		$V_{IN} \leq 1.5V$	$0.8 \times V_{IN}$		V
V_{IL}	EN input low voltage		$5V > V_{IN} > 1.5V$		0.4	V
V_{IH}	EN input high voltage		$5V > V_{IN} > 1.5V$	1.2		V
V_{UVLO}	Undervoltage lockout threshold for turn off		V_{IN} decreasing	0.5	0.7	V
	Overvoltage protection threshold			5.5	7.5	V
	Overtemperature protection			140		$^\circ C$
	Overtemperature hysteresis			20		$^\circ C$

6.6 Typical Characteristics

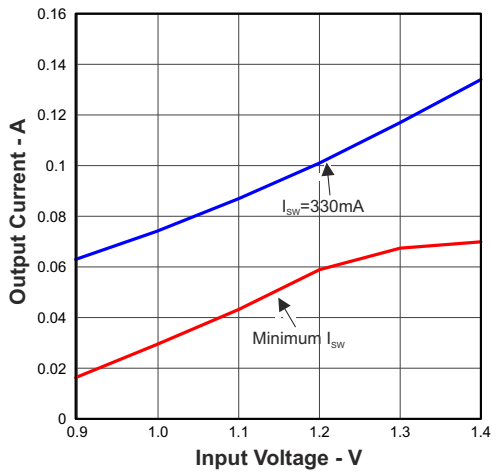

$V_O = 1.8\text{ V}$
Figure 6-1. Maximum Output Current vs Input Voltage

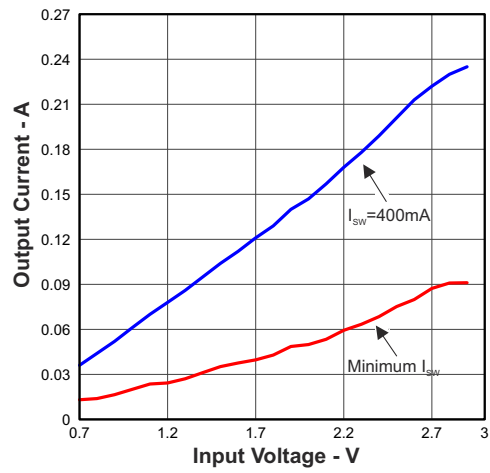

$V_O = 3.3\text{ V}$
Figure 6-2. Maximum Output Current vs Input Voltage

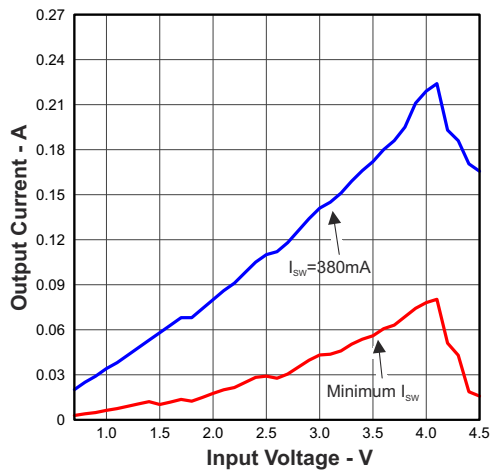

$V_O = 5\text{ V}$
Figure 6-3. Maximum Output Current vs Input Voltage

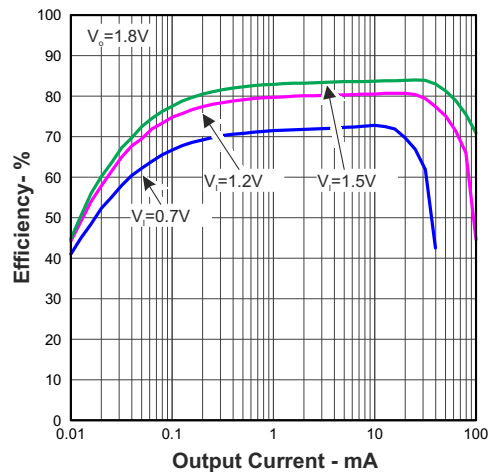

Figure 6-4. Efficiency vs Output Current and Input Voltage

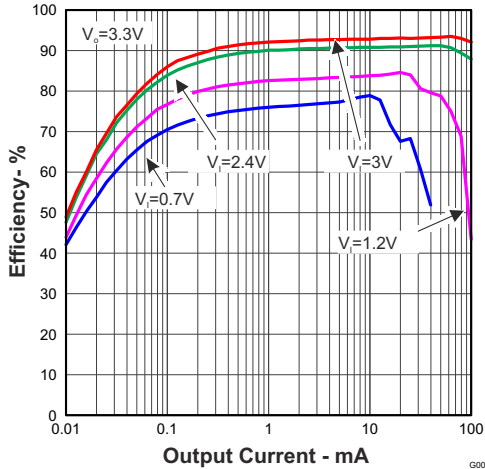

Figure 6-5. Efficiency vs Output Current and Input Voltage

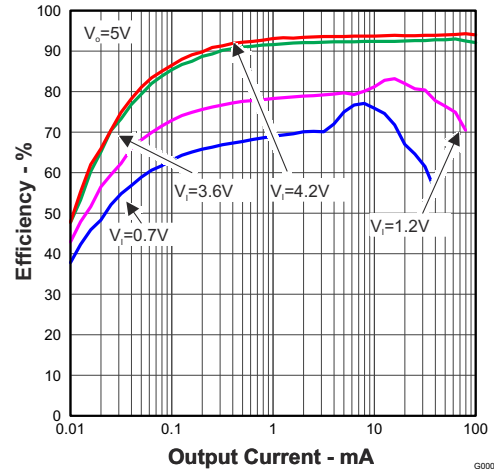

Figure 6-6. Efficiency vs Input Voltage and Output Current

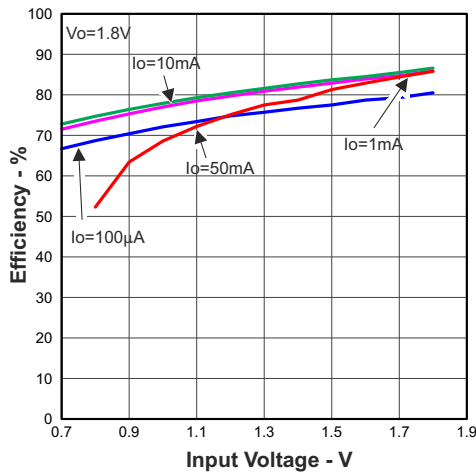

Figure 6-7. Efficiency vs Input Voltage and Output Current

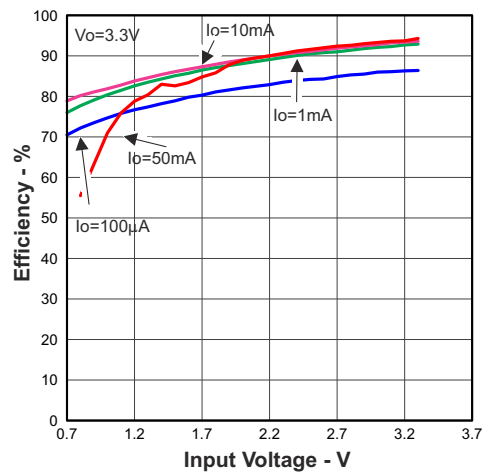

Figure 6-8. Efficiency vs Input Voltage and Output Current

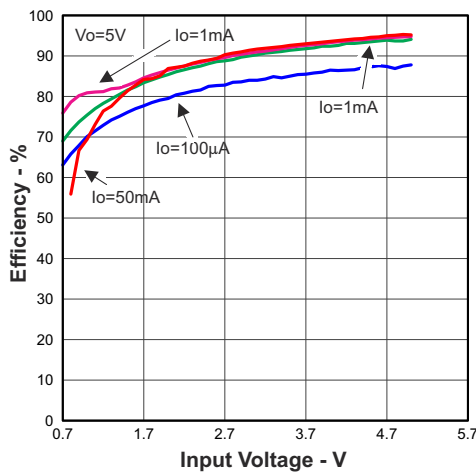

Figure 6-9. Efficiency vs Input Voltage and Output Current

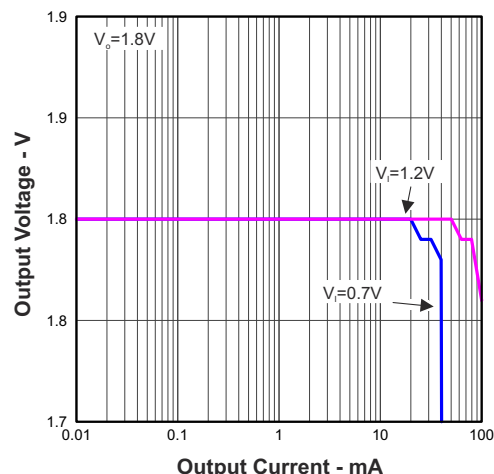

Figure 6-10. Output Voltage vs Output Current and Input Voltage

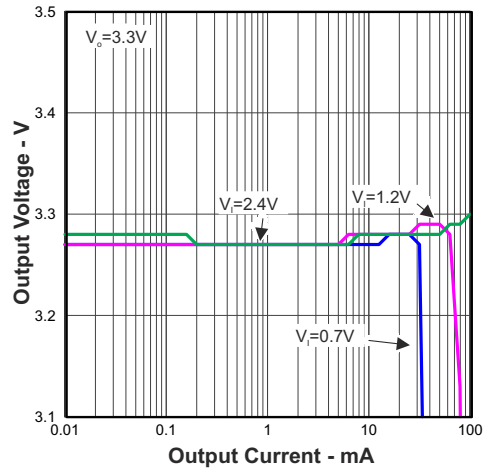

Figure 6-11. Output Voltage vs Output Current and Input Voltage

7 Parameter Measurement Information

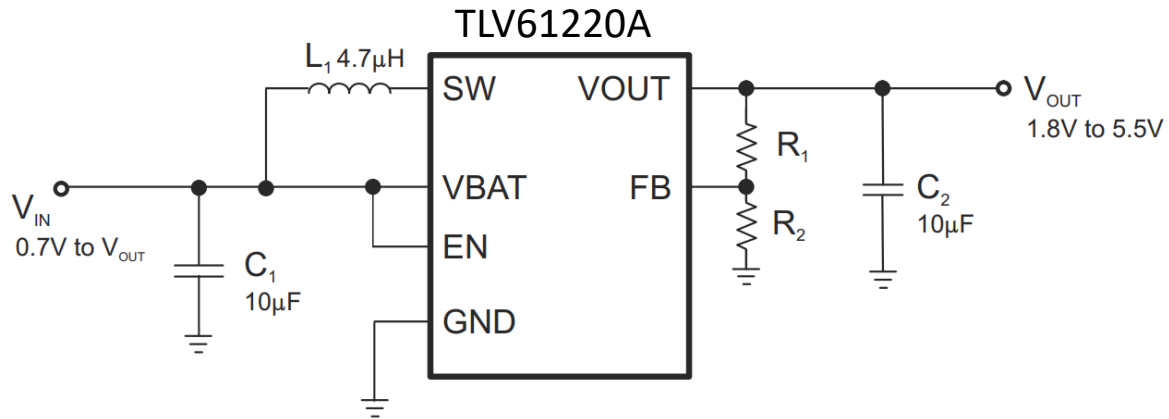

Figure 7-1. Parameter Measurement Schematic

8 Detailed Description

8.1 Overview

The TLV61220A is a high performance, highly efficient boost converter. To achieve high efficiency the power stage is realized as a synchronous boost topology. For the power switching two actively controlled low $R_{DS(on)}$ power MOSFETs are implemented.

8.2 Functional Block Diagram

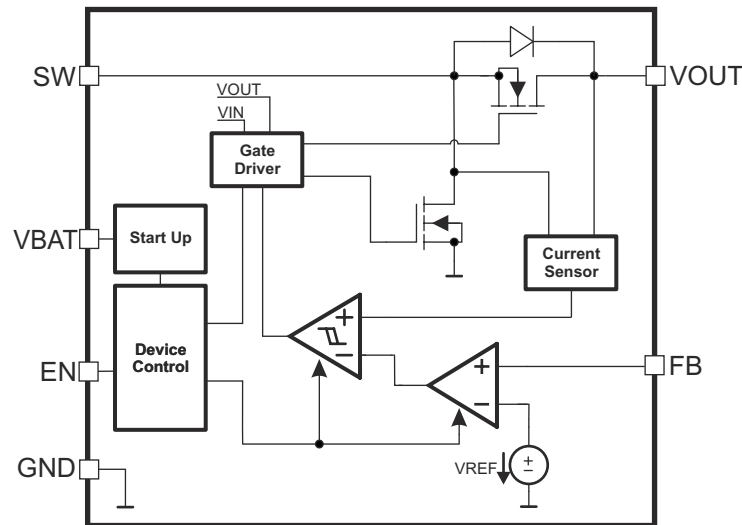

8.3 Feature Description

8.3.1 Controller Circuit

The device is controlled by a hysteretic current mode controller. This controller regulates the output voltage by keeping the inductor ripple current constant in the range of 200 mA and adjusting the offset of this inductor current depending on the output load. In case the required average input current is lower than the average inductor current defined by this constant ripple the inductor current gets discontinuous to keep the efficiency high at low load conditions.

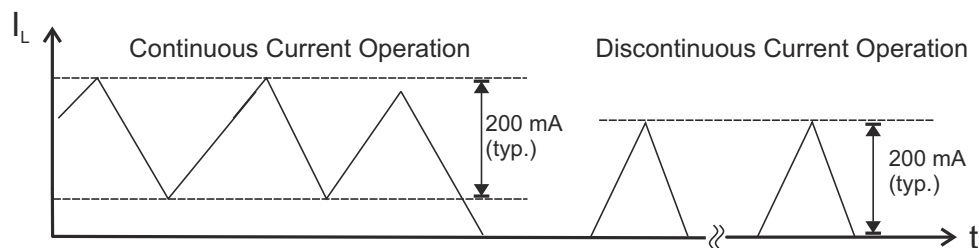

Figure 8-1. Hysteretic Current Operation

The output voltage V_{OUT} is monitored via the feedback network which is connected to the voltage error amplifier. To regulate the output voltage, the voltage error amplifier compares this feedback voltage to the internal voltage reference and adjusts the required offset of the inductor current accordingly. An external resistor divider needs to be connected.

The self oscillating hysteretic current mode architecture is inherently stable and allows fast response to load variations. It also allows using inductors and capacitors over a wide value range.

8.3.1.1 Startup

After the EN pin is tied high, the device starts to operate. In case the input voltage is not high enough to supply the control circuit properly a startup oscillator starts to operate the switches. During this phase the switching

frequency is controlled by the oscillator and the maximum switch current is limited. As soon as the device has built up the output voltage to about 1.8 V, high enough for supplying the control circuit, the device switches to its normal hysteretic current mode operation. The startup time depends on input voltage and load current.

8.3.1.2 Operation at Output Overload

If in normal boost operation the inductor current reaches the internal switch current limit threshold the main switch is turned off to stop further increase of the input current.

In this case the output voltage will decrease since the device can not provide sufficient power to maintain the set output voltage.

If the output voltage drops below the input voltage the backgate diode of the rectifying switch gets forward biased and current starts flow through it. This diode cannot be turned off, so the current finally is only limited by the remaining DC resistances. As soon as the overload condition is removed, the converter resumes providing the set output voltage.

8.3.1.3 Undervoltage Lockout

An implemented undervoltage lockout function stops the operation of the converter if the input voltage drops below the typical undervoltage lockout threshold. This function is implemented in order to prevent malfunctioning of the converter.

8.3.1.4 Overvoltage Protection

If, for any reason, the output voltage is not fed back properly to the input of the voltage amplifier, control of the output voltage will not work anymore. Therefore an overvoltage protection is implemented to avoid the output voltage exceeding critical values for the device and possibly for the system it is supplying. For this protection the TLV61220A output voltage is also monitored internally. In case it reaches the internally programmed threshold of 6.5 V typically the voltage amplifier regulates the output voltage to this value.

If the TLV61220A is used to drive LEDs, this feature protects the circuit if the LED fails.

8.3.1.5 Overtemperature Protection

The device has a built-in temperature sensor which monitors the internal IC junction temperature. If the temperature exceeds the programmed threshold (see electrical characteristics table), the device stops operating. As soon as the IC temperature has decreased below the programmed threshold, it starts operating again. To prevent unstable operation close to the region of overtemperature threshold, a built-in hysteresis is implemented.

8.4 Device Functional Modes

8.4.1 Device Enable and Shutdown Mode

The device is enabled when EN is set high and shut down when EN is low. During shutdown, the converter stops switching and all internal control circuitry is turned off. In this case the input voltage is connected to the output through the back-gate diode of the rectifying MOSFET. This means that there always will be voltage at the output which can be as high as the input voltage or lower depending on the load.

9 Application and Implementation

Note

Information in the following applications sections is not part of the TI component specification, and TI does not warrant its accuracy or completeness. TI's customers are responsible for determining suitability of components for their purposes. Customers should validate and test their design implementation to confirm system functionality.

9.1 Application Information

The TLV61220A is intended for systems powered by a single cell battery to up to three Alkaline, NiCd or NiMH cells with a typical terminal voltage between 0.7 V and 5.5 V. It can also be used in systems powered by one-cell Li-Ion or Li-Polymer batteries with a typical voltage between 2.5 V and 4.2 V. Additionally, any other voltage source with a typical output voltage between 0.7 V and 5.5 V can be used with the TLV61220A.

9.2 Typical Application

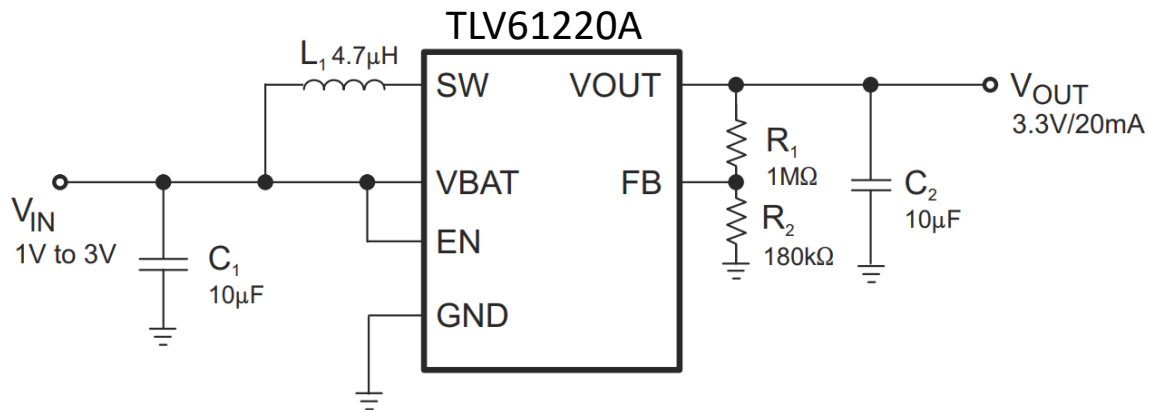

Figure 9-1. Typical Application Circuit for Adjustable Output Voltage Option

9.2.1 Design Requirements

In this example, TLV61220A is used to design a 3.3V power supply with up to 50mA output current capability. The TLV61220A can be powered by a single-cell battery to up to three Alkaline, NiCd or NiMH cells with a typical terminal voltage between 0.7V and 5.5V. It can also be used in systems powered by one-cell Li-Ion or Li-Polymer batteries with a typical voltage between 2.5V and 4.2V. In this example, the input voltage range is from 2V to 3V for one-cell coin cell battery input design.

Table 9-1. TLV61220A 3.3 V Output Design Requirements

PARAMETERS	VALUES
Input Voltage	2V to 3V
Output Voltage	3.3V
Output Current	50mA

9.2.2 Detailed Design Procedure

Table 9-2. List of Components

COMPONENT REFERENCE	PART NUMBER	MANUFACTURER	VALUE
C ₁	GRM188R60J106ME84D	Murata	10μF, 6.3V. X5R Ceramic
C ₂	GRM188R60J106ME84D	Murata	10μF, 6.3V. X5R Ceramic
L ₁	1269AS-H-4ZR7N	Toko	4.7μH
R ₁ , R ₂			R ₁ = 1MΩ, R ₂ = Values depending on the programmed output voltage

9.2.2.1 Adjustable Output Voltage Version

An external resistor divider is used to adjust the output voltage. The resistor divider needs to be connected between V_{OUT}, FB and GND as shown in [Figure 9-1](#). When the output voltage is regulated properly, the typical voltage value at the FB pin is 500 mV. The maximum recommended value for the output voltage is 5.5 V. The current through the resistive divider should be about 100 times greater than the current into the FB pin. The typical current into the FB pin is 0.01 μA, and the voltage across the resistor between FB and GND, R₂, is typically 500 mV. Based on those two values, the recommended value for R₂ should be lower than 500 kΩ, in order to set the divider current to 1 μA or higher. The value of the resistor connected between V_{OUT} and FB, R₁, depending on the needed output voltage (V_{OUT}), can be calculated using [Equation 1](#):

$$R_1 = R_2 \times \left(\frac{V_{OUT}}{V_{FB}} - 1 \right) \quad (1)$$

As an example, if an output voltage of 3.3 V is needed, a 1-MΩ resistor is calculated for R₁ when for R₂ a 180-kΩ has been selected.

9.2.2.2 Inductor Selection

To make sure that the TLV61220A can operate, a suitable inductor must be connected between pin VBAT and pin SW. Inductor values of 4.7 μH show good performance over the whole input and output voltage range .

Choosing other inductance values affects the switching frequency *f* proportional to 1/L as shown in [Equation 2](#).

$$L = \frac{1}{f \times 200 \text{ mA}} \times \frac{V_{IN} \times (V_{OUT} - V_{IN})}{V_{OUT}} \quad (2)$$

Choosing inductor values higher than 4.7 μH can improve efficiency due to reduced switching frequency and, therefore, with reduced switching losses. Using inductor values below 2.2 μH is not recommended.

Having selected an inductance value, the peak current for the inductor in steady state operation can be calculated. [Equation 3](#) gives the peak current estimate.

$$I_{L,MAX} = \begin{cases} \frac{V_{OUT} \times I_{OUT}}{0.8 \times V_{IN}} + 100 \text{ mA}; & \text{continuous current operation} \\ 200 \text{ mA}; & \text{discontinuous current operation} \end{cases} \quad (3)$$

For selecting the inductor this would be the suitable value for the current rating. It also needs to be taken into account that load transients and error conditions may cause higher inductor currents.

[Equation 4](#) helps to estimate whether the device will work in continuous or discontinuous operation depending on the operating points. As long as the inequation is true, continuous operation is typically established. If the inequation becomes false, discontinuous operation is typically established.

$$\frac{V_{\text{OUT}} \times I_{\text{OUT}}}{V_{\text{IN}}} > 0.8 \times 100 \text{ mA} \quad (4)$$

The following inductor series from different suppliers have been used with TLV61220A converters:

Table 9-3. List of Inductors

VENDOR	INDUCTOR SERIES
Toko	DFE252010C
Coilcraft	EPL3015
	EPL2010
Murata	LQH3NP
Taiyo Yuden	NR3015
Würth Elektronik	WE-TPC Typ S

9.2.2.3 Capacitor Selection

9.2.2.3.1 Input Capacitor

At least a 10- μF input capacitor is recommended to improve transient behavior of the regulator and EMI behavior of the total power supply circuit. A ceramic capacitor placed as close as possible to the VBAT and GND pins of the IC is recommended.

9.2.2.3.2 Output Capacitor

For the output capacitor C_2 , it is recommended to use small ceramic capacitors placed as close as possible to the VOUT and GND pins of the IC. If, for any reason, the application requires the use of large capacitors which can not be placed close to the IC, the use of a small ceramic capacitor with an capacitance value of around 2.2 μF in parallel to the large one is recommended. This small capacitor should be placed as close as possible to the VOUT and GND pins of the IC.

A minimum capacitance value of 4.7 μF should be used, 10 μF are recommended. If the inductor value exceeds 4.7 μH , the value of the output capacitance value needs to be half the inductance value or higher for stability reasons, see [Equation 5](#).

$$C_2 \geq \frac{L}{2} \times \frac{\mu\text{F}}{\mu\text{H}} \quad (5)$$

The TLV61220A is not sensitive to the ESR in terms of stability. Using low ESR capacitors, such as ceramic capacitors, is recommended anyway to minimize output voltage ripple. If heavy load changes are expected, the output capacitor value should be increased to avoid output voltage drops during fast load transients.

9.2.3 Application Curves

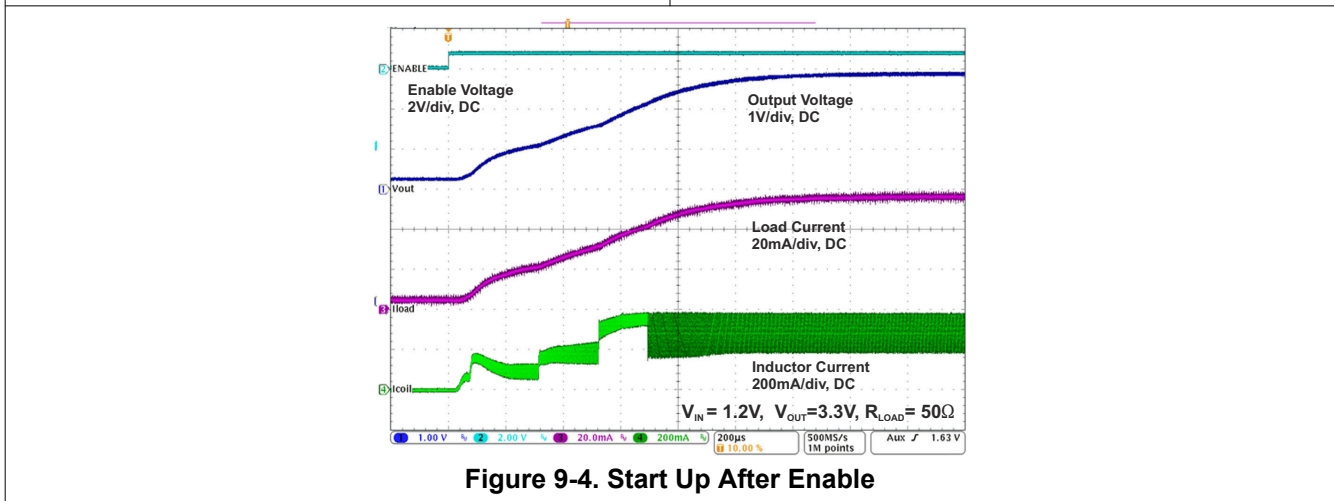
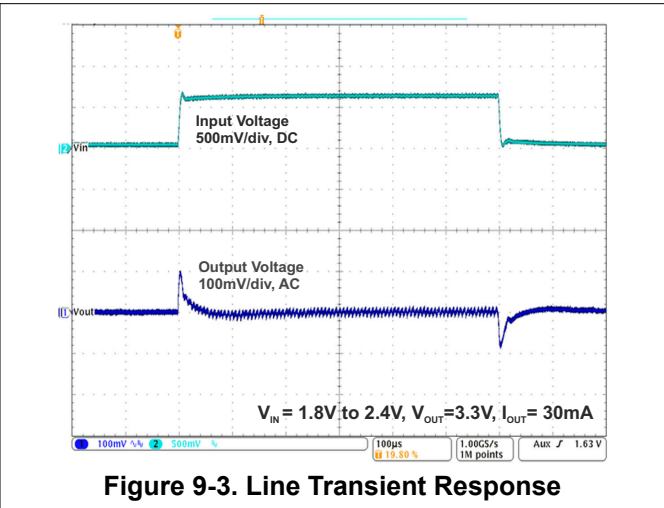
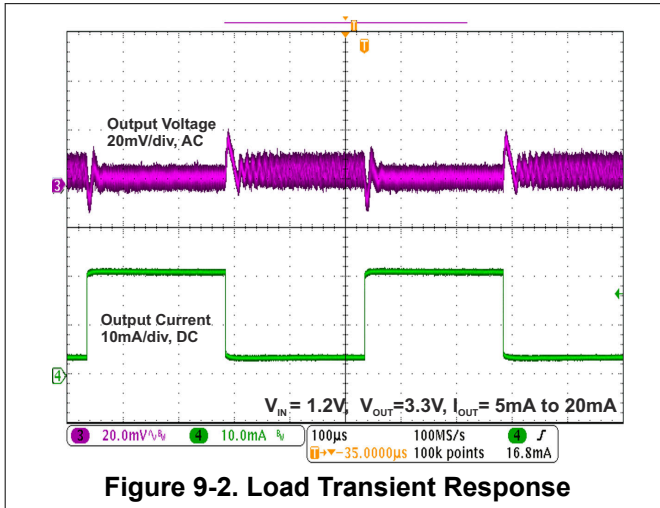

10 Power Supply Recommendations

The power supply can be single-cell, two-cell, or three-cell alkaline, NiCd or NiMH, or one-cell Li-Ion or Li-polymer battery.

The input supply should be well regulated with the rating of TLV61220A. If the input supply is located more than a few inches from the device, additional bulk capacitance may be required in addition to the ceramic bypass capacitors. An electrolytic or tantalum capacitor with a value of 47 μF is a typical choice.

11 Layout

11.1 Layout Guidelines

As for all switching power supplies, the layout is an important step in the design, especially at high peak currents and high switching frequencies. If the layout is not carefully done, the regulator could show stability problems as well as EMI problems. Therefore, use wide and short traces for the main current path and for the power ground paths. The input and output capacitor, as well as the inductor should be placed as close as possible to the IC.

The feedback divider should be placed as close as possible to the control ground pin of the IC. To lay out the ground, it is recommended to use short traces as well, separated from the power ground traces. This avoids ground shift problems, which can occur due to superimposition of power ground current and control ground current. Assure that the ground traces are connected close to the device GND pin.

11.2 Layout Example

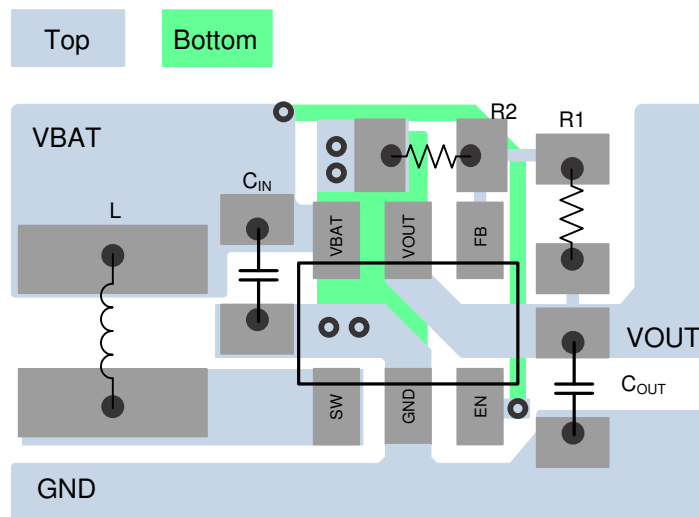

Figure 11-1. PCB Layout Recommendation

11.3 Thermal Considerations

Implementation of integrated circuits in low-profile and fine-pitch surface-mount packages typically requires special attention to power dissipation. Many system-dependent issues such as thermal coupling, airflow, added heat sinks and convection surfaces, and the presence of other heat-generating components affect the power-dissipation limits of a given component.

Three basic approaches for enhancing thermal performance are listed below:

- Improving the power-dissipation capability of the PCB design.
- Improving the thermal coupling of the component to the PCB.
- Introducing airflow into the system.

For more details on how to use the thermal parameters in the dissipation ratings table please check the [Thermal Characteristics Application Note](#) and the [IC Package Thermal Metrics Application Note](#).

12 Device and Documentation Support

12.1 Third-Party Products Disclaimer

TI'S PUBLICATION OF INFORMATION REGARDING THIRD-PARTY PRODUCTS OR SERVICES DOES NOT CONSTITUTE AN ENDORSEMENT REGARDING THE SUITABILITY OF SUCH PRODUCTS OR SERVICES OR A WARRANTY, REPRESENTATION OR ENDORSEMENT OF SUCH PRODUCTS OR SERVICES, EITHER ALONE OR IN COMBINATION WITH ANY TI PRODUCT OR SERVICE.

12.2 Documentation Support

12.2.1 Related Documentation

- Texas Instruments, [Thermal Characteristics Application Note](#)
- Texas Instruments, [IC Package Thermal Metrics Application Note](#)

12.3 Receiving Notification of Documentation Updates

To receive notification of documentation updates, navigate to the device product folder on [ti.com](https://www.ti.com). Click on *Notifications* to register and receive a weekly digest of any product information that has changed. For change details, review the revision history included in any revised document.

12.4 Support Resources

[TI E2E™ support forums](#) are an engineer's go-to source for fast, verified answers and design help — straight from the experts. Search existing answers or ask your own question to get the quick design help you need.

Linked content is provided "AS IS" by the respective contributors. They do not constitute TI specifications and do not necessarily reflect TI's views; see TI's [Terms of Use](#).

12.5 Trademarks

TI E2E™ is a trademark of Texas Instruments.
All trademarks are the property of their respective owners.

12.6 Electrostatic Discharge Caution



This integrated circuit can be damaged by ESD. Texas Instruments recommends that all integrated circuits be handled with appropriate precautions. Failure to observe proper handling and installation procedures can cause damage.

ESD damage can range from subtle performance degradation to complete device failure. Precision integrated circuits may be more susceptible to damage because very small parametric changes could cause the device not to meet its published specifications.

12.7 Glossary

[TI Glossary](#) This glossary lists and explains terms, acronyms, and definitions.

13 Revision History

NOTE: Page numbers for previous revisions may differ from page numbers in the current version.

DATE	REVISION	NOTES
November 2024	*	Initial Release

Mechanical, Packaging, and Orderable Information

The following pages include mechanical, packaging, and orderable information. This information is the most current data available for the designated devices. This data is subject to change without notice and revision of this document. For browser-based versions of this data sheet, refer to the left-hand navigation.

IMPORTANT NOTICE AND DISCLAIMER

TI PROVIDES TECHNICAL AND RELIABILITY DATA (INCLUDING DATA SHEETS), DESIGN RESOURCES (INCLUDING REFERENCE DESIGNS), APPLICATION OR OTHER DESIGN ADVICE, WEB TOOLS, SAFETY INFORMATION, AND OTHER RESOURCES "AS IS" AND WITH ALL FAULTS, AND DISCLAIMS ALL WARRANTIES, EXPRESS AND IMPLIED, INCLUDING WITHOUT LIMITATION ANY IMPLIED WARRANTIES OF MERCHANTABILITY, FITNESS FOR A PARTICULAR PURPOSE OR NON-INFRINGEMENT OF THIRD PARTY INTELLECTUAL PROPERTY RIGHTS.

These resources are intended for skilled developers designing with TI products. You are solely responsible for (1) selecting the appropriate TI products for your application, (2) designing, validating and testing your application, and (3) ensuring your application meets applicable standards, and any other safety, security, regulatory or other requirements.

These resources are subject to change without notice. TI grants you permission to use these resources only for development of an application that uses the TI products described in the resource. Other reproduction and display of these resources is prohibited. No license is granted to any other TI intellectual property right or to any third party intellectual property right. TI disclaims responsibility for, and you will fully indemnify TI and its representatives against, any claims, damages, costs, losses, and liabilities arising out of your use of these resources.

TI's products are provided subject to [TI's Terms of Sale](#) or other applicable terms available either on [ti.com](https://www.ti.com) or provided in conjunction with such TI products. TI's provision of these resources does not expand or otherwise alter TI's applicable warranties or warranty disclaimers for TI products.

TI objects to and rejects any additional or different terms you may have proposed.

Mailing Address: Texas Instruments, Post Office Box 655303, Dallas, Texas 75265
Copyright © 2024, Texas Instruments Incorporated