

# UCC27511A Single-Channel High-Speed Low-Side Gate Driver

## With 4A Peak Source and 8A Peak Sink

### 1 Features

- Input Pins Capable of Withstanding  $-5V$  Below GND pin
- Low-Cost Gate-Driver Device Offering Superior Replacement of NPN and PNP Discrete Solutions
- Strong Sink Current Offers Enhanced Immunity Against Miller Turnon
- Split Output Configuration (Allows Easy and Independent Adjustment of Turnon and Turnoff Speeds)
- Fast Propagation Delays (13ns typical)
- Fast Rise and Fall Times (8ns and 7ns typical)
- 4.5V to 18V Single Supply Range
- Outputs Held Low During  $V_{DD}$  UVLO (Ensures Glitch-Free Operation at Power Up and Power Down)
- TTL and CMOS Compatible Input-Logic Threshold (Independent of Supply Voltage)
- Wide Hysteresis (1V typical) for High-Noise Immunity
- Dual-Input Design (Choice of an Inverting (IN– Pin) or Non-Inverting (IN+ Pin) Driver Configuration)
  - Unused Input Pin can be Used for Enable or Disable Function
- Output Held Low when Input Pins are Floating
- Input Pin Absolute Maximum Voltage Levels Not Restricted by  $V_{DD}$  Pin Bias Supply Voltage

### 2 Applications

- Switch-Mode Power Supplies
- DC-to-DC Converters
- Companion Gate-Driver Devices for Digital Power Controllers
- Solar Power, Motor Control, UPS
- Gate Driver for Emerging Wide Band-Gap Power Devices (such as GaN)

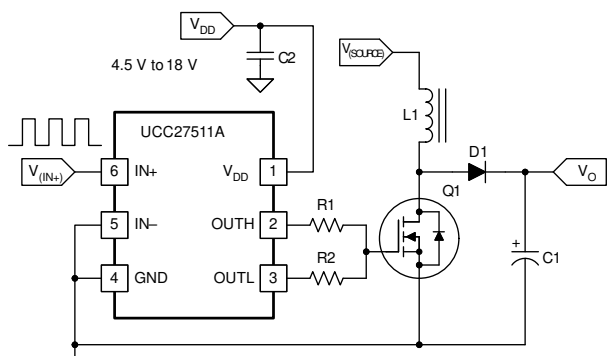
### 3 Description

The UCC27511A device is a compact gate driver that offers superior replacement of NPN and PNP discrete driver (buffer circuit) solutions. The UCC27511A device is a single-channel low-side, high-speed gate driver rated for MOSFETs, IGBTs, and emerging wide-bandgap power devices such as GaN. The device features fast rise times, fall times, and propagation delays, making the UCC27511A device suitable for high-speed applications. Its asymmetrical 4A peak source and 8A peak sink currents boost immunity against parasitic Miller turnon effect. The split output configuration enables easy and independent adjustment of rise and fall times using only two resistors and eliminating the need for an external diode. Features including wide input hysteresis and negative input voltage handling enhance transient immunity.

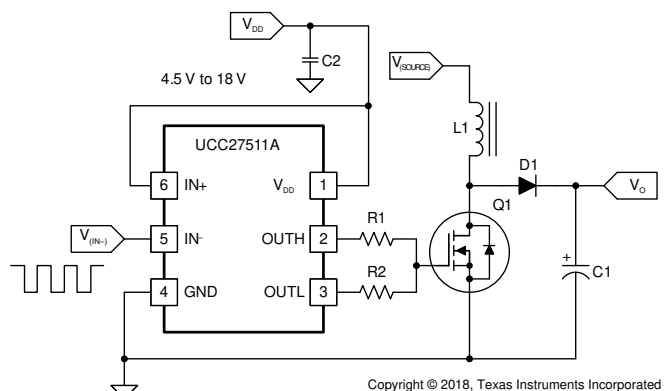
### Device Information

PART NUMBER	PACKAGE <sup>(1)</sup>	BODY SIZE (NOM)
UCC27511A	DBV (SOT-23 6)	2.90mm × 1.60mm

(1) For all available packages, see [Section 12](#).



**Non-Inverting Input Application Diagram**



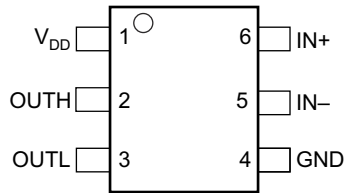
**Inverting Input Application Diagram**



## Table of Contents

<b>1 Features</b> .....	<b>1</b>	<b>7 Application and Implementation</b> .....	<b>19</b>
<b>2 Applications</b> .....	<b>1</b>	7.1 Application Information.....	19
<b>3 Description</b> .....	<b>1</b>	7.2 Typical Application.....	20
<b>4 Pin Configuration and Functions</b> .....	<b>3</b>	<b>8 Power Supply Recommendations</b> .....	<b>25</b>
<b>5 Specifications</b> .....	<b>4</b>	<b>9 Layout</b> .....	<b>26</b>
5.1 Absolute Maximum Ratings.....	4	9.1 Layout Guidelines.....	26
5.2 Handling Ratings.....	4	9.2 Layout Example.....	26
5.3 Recommended Operating Conditions.....	4	<b>10 Device and Documentation Support</b> .....	<b>27</b>
5.4 Thermal Information .....	5	10.1 Device Support.....	27
5.5 Electrical Characteristics.....	5	10.2 Receiving Notification of Documentation Updates..	27
5.6 Switching Characteristics.....	7	10.3 Support Resources.....	27
5.7 Typical Characteristics.....	9	10.4 Trademarks.....	27
<b>6 Detailed Description</b> .....	<b>12</b>	10.5 Electrostatic Discharge Caution.....	27
6.1 Overview.....	12	10.6 Glossary.....	27
6.2 Functional Block Diagram.....	13	<b>11 Revision History</b> .....	<b>28</b>
6.3 Feature Description.....	13	<b>12 Mechanical, Packaging, and Orderable Information</b> .....	<b>28</b>
6.4 Device Functional Modes.....	18		

## 4 Pin Configuration and Functions



**Figure 4-1. DBV Package 6-Pin SOT-23 Top View**

**Table 4-1. Pin Functions**

PIN		I/O	FUNCTION
NO.	NAME		
4	GND	—	Ground. All signals referenced to this pin.
6	IN+	I	Non-inverting input. When used in inverting configuration, connect the IN+ pin to $V_{DD}$ to enable output. To disable output connect the IN+ pin to GND or leave floating.
5	IN-	I	Inverting input. When used in non-inverting configuration, connect the IN- pin to GND to enable output. To disable the output connect the IN- pin to $V_{DD}$ or leave floating.
2	OUTH	O	Sourcing current output of driver. Connect a resistor between the OUTH pin and the gate of the power-switching device to adjust turnon speed.
3	OUTL	O	Sinking current output of driver. Connect a resistor between the OUTL pin and the gate of the power-switching device to adjust turnoff speed.
1	$V_{DD}$	I	Bias supply input.

## 5 Specifications

### 5.1 Absolute Maximum Ratings

over operating free-air temperature range (unless otherwise noted) <sup>(1)</sup> <sup>(2)</sup> <sup>(3)</sup>

		MIN	MAX	UNIT
Supply voltage	$V_{DD}$	-0.3	20	V
Input voltage	IN+, IN- <sup>(4)</sup>	-6	20	
Output voltage	OUTH	-0.3	$V_{DD} + 0.3$	
	OUTL	DC	-0.3	
		Repetitive pulse less than 200 ns <sup>(5)</sup>	-2	20
Output continuous current (OUTH source current and OUTL sink current)	$I_{O\_DC}$ (source)		0.3	A
	$I_{O\_DC}$ (sink)		0.6	
Output pulsed current (0.5 $\mu$ s) (OUTH source current and OUTL sink current)	$I_{O\_pulsed}$ (source)		4	
	$I_{O\_pulsed}$ (sink)		8	
Operating virtual junction temperature range, $T_J$		-40	150	°C
Lead temperature	Soldering, 10 sec.		300	
	Reflow		260	

- Stresses beyond those listed under *absolute maximum ratings* may cause permanent damage to the device. These are stress ratings only and functional operation of the device at these or any other conditions beyond those indicated under *recommended operating conditions* is not implied. Exposure to absolute-maximum-rated conditions for extended periods may affect device reliability.
- All voltages are with respect to GND unless otherwise noted. Currents are positive into and negative out of the specified terminal. See the [Section 7.2.2.7](#) for thermal limitations and considerations of packages.
- These devices are sensitive to electrostatic discharge; follow proper device handling procedures.
- Maximum voltage on input pins is not restricted by the voltage on the  $V_{DD}$  pin.
- Values are verified by characterization on bench.

### 5.2 Handling Ratings

		MIN	MAX	UNIT	
$T_{stg}$	Storage temperature range	-65	150	°C	
$V_{(ESD)}$	Electrostatic discharge	Human body model (HBM), per ANSI/ESDA/JEDEC JS-001, all pins <sup>(1)</sup>	-4000	4000	V
		Charged device model (CDM), per JEDEC specification JESD22-C101, all pins <sup>(2)</sup>	-1000	1000	

- JEDEC document JEP155 states that 500-V HBM allows safe manufacturing with a standard ESD control process.
- JEDEC document JEP157 states that 250-V CDM allows safe manufacturing with a standard ESD control process.

### 5.3 Recommended Operating Conditions

over operating free-air temperature range (unless otherwise noted)

		MIN	NOM	MAX	UNIT
$V_{DD}$	Supply voltage	4.5	12	18	V
$V_I$	Input voltage, IN+ and IN-	-5		18	V
$T_A$	Operating junction temperature range	-40		140	°C

## 5.4 Thermal Information

THERMAL METRIC <sup>(1)</sup>		DBV	UNIT
		6 PINS	
R <sub>θJA</sub>	Junction-to-ambient thermal resistance	217.8	°C/W
R <sub>θJC(top)</sub>	Junction-to-case (top) thermal resistance	97.6	
R <sub>θJB</sub>	Junction-to-board thermal resistance	72.2	
Ψ <sub>JT</sub>	Junction-to-top characterization parameter	8.6	
Ψ <sub>JB</sub>	Junction-to-board characterization parameter	71.6	

(1) For more information about traditional and new thermal metrics, see the [IC Package Thermal Metrics Application Report](#).

## 5.5 Electrical Characteristics

V<sub>DD</sub> = 12 V, T<sub>A</sub> = T<sub>J</sub> = –40°C to 140°C, 1-μF capacitor from V<sub>DD</sub> to GND. Currents are positive into, negative out of the specified terminal.

PARAMETER		TEST CONDITIONS	MIN	TYP	MAX	UNIT	
<b>BIAS CURRENTS</b>							
I <sub>(START)</sub>	Startup current	V <sub>DD</sub> = 3.4 V	IN+ = V <sub>DD</sub> , IN– = GND	40	100	160	μA
			IN+ = IN– = GND or IN+ = IN– = V <sub>DD</sub>	25	75	145	
			IN+ = GND, IN– = V <sub>DD</sub>	20	60	115	
<b>UNDERVOLTAGE LOCKOUT (UVLO)</b>							
V <sub>(ON)</sub>	Supply start threshold	T <sub>A</sub> = 25°C	3.91	4.2	4.5	V	
		T <sub>A</sub> = –40°C to 140°C	3.7	4.2	4.65		
V <sub>(OFF)</sub>	Minimum operating voltage after supply start		3.45	3.9	4.35		
V <sub>DD(hys)</sub>	Supply voltage hysteresis		0.2	0.3	0.5		
<b>INPUTS (IN+, IN–)</b>							
V <sub>IH(IN)</sub>	Input signal high threshold	Output high for IN+ pin, Output low for IN– pin		2.2	2.4	V	
V <sub>IL(IN)</sub>	Input signal low threshold	Output low for IN+ pin, Output high for IN– pin	1.0	1.2			
V <sub>hys(IN)</sub>	Input signal hysteresis			1			
<b>SOURCE AND SINK CURRENT</b>							
I <sub>P(SRC)</sub>	Source peak current <sup>(1)</sup>	C <sub>(LOAD)</sub> = 0.22 μF, f <sub>S</sub> = 1 kHz		–4		A	
I <sub>P(SNK)</sub>	Sink peak current <sup>(1)</sup>	C <sub>(LOAD)</sub> = 0.22 μF, f <sub>S</sub> = 1 kHz		8		A	
<b>OUTPUTS (OUTH, OUTL, OUT)</b>							
V <sub>OH</sub>	High output voltage	V <sub>DD</sub> = 12 V I <sub>(OUTH)</sub> = –10 mA		50	90	mV	
		V <sub>DD</sub> = 4.5 V I <sub>(OUTH)</sub> = –10 mA		60	130		
V <sub>OL</sub>	Low output voltage	V <sub>DD</sub> = 12 I <sub>(OUTL)</sub> = 10 mA		5	6.5		
		V <sub>DD</sub> = 4.5 V I <sub>(OUTL)</sub> = 10 mA		5.5	10		

## 5.5 Electrical Characteristics (continued)

$V_{DD} = 12\text{ V}$ ,  $T_A = T_J = -40^\circ\text{C}$  to  $140^\circ\text{C}$ ,  $1\text{-}\mu\text{F}$  capacitor from  $V_{DD}$  to GND. Currents are positive into, negative out of the specified terminal.

PARAMETER		TEST CONDITIONS	MIN	TYP	MAX	UNIT
$R_{O(H)}$	Output pullup resistance <sup>(2)</sup>	$V_{DD} = 12\text{ V}$ $I_{(OUTH)} = -10\text{ mA}$		5	7.5	$\Omega$
		$V_{DD} = 4.5\text{ V}$ $I_{(OUTH)} = -10\text{ mA}$		5	11	
$R_{O(L)}$	Output pulldown resistance	$V_{DD} = 12\text{ V}$ $I_{(OUTL)} = 10\text{ mA}$		0.375	0.65	
		$V_{DD} = 4.5\text{ V}$ $I_{(OUTL)} = 10\text{ mA}$		0.45	0.75	

(1) Ensured by Design.

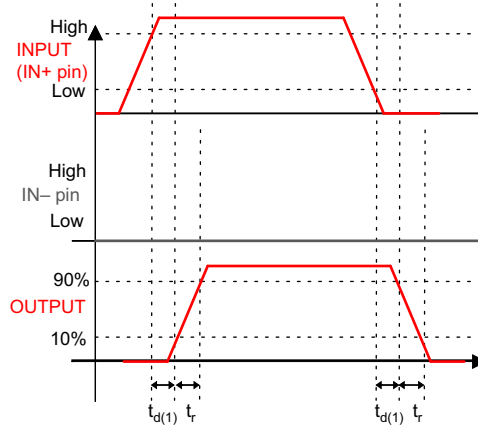
(2)  $R_{O(H)}$  represents the on-resistance of P-channel MOSFET in pullup structure of the output stage of the UCC27511A device.

### 5.6 Switching Characteristics

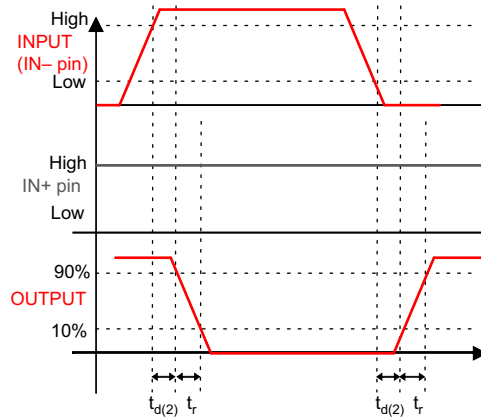
$V_{DD} = 12\text{ V}$ ,  $T_A = T_J = -40^\circ\text{C}$  to  $140^\circ\text{C}$ ,  $1\text{-}\mu\text{F}$  capacitor from  $V_{DD}$  to GND. Currents are positive into, negative out of the specified terminal. See [Figure 5-1](#), [Figure 5-2](#), [Figure 5-3](#), and [Figure 5-4](#)

PARAMETER	TEST CONDITIONS	MIN	TYP	MAX	UNIT
$t_r$ Rise time <sup>(1)</sup>	$V_{DD} = 12\text{ V}$ $C_{(LOAD)} = 1.8\text{ nF}$ , connected to OUTH and OUTL pins tied together		8	12	ns
	$V_{DD} = 4.5\text{ V}$ $C_{(LOAD)} = 1.8\text{ nF}$		16	22	
$t_f$ Fall time <sup>(1)</sup>	$V_{DD} = 12\text{ V}$ $C_{(LOAD)} = 1.8\text{ nF}$ , connected to OUTH and OUTL pins tied together		7	11	ns
	$V_{DD} = 4.5\text{ V}$ $C_{(LOAD)} = 1.8\text{ nF}$		7	11	
$t_{d(1)}$ IN+ to output propagation delay <sup>(1)</sup>	$V_{DD} = 12\text{ V}$ 5-V input pulse $C_{(LOAD)} = 1.8\text{ nF}$ , connected to OUTH and OUTL pins tied together	4	13	23	ns
	$V_{DD} = 4.5\text{ V}$ 5-V input pulse $C_{(LOAD)} = 1.8\text{ nF}$ , connected to OUTH and OUTL pins tied together	4	15	26	
$t_{d(2)}$ IN- to output propagation delay <sup>(1)</sup>	$V_{DD} = 12\text{ V}$ $C_{(LOAD)} = 1.8\text{ nF}$ , connected to OUTH and OUTL pins tied together	4	13	23	ns
	$V_{DD} = 4.5\text{ V}$ $C_{(LOAD)} = 1.8\text{ nF}$ , connected to OUTH and OUTL pins tied together	4	19	30	

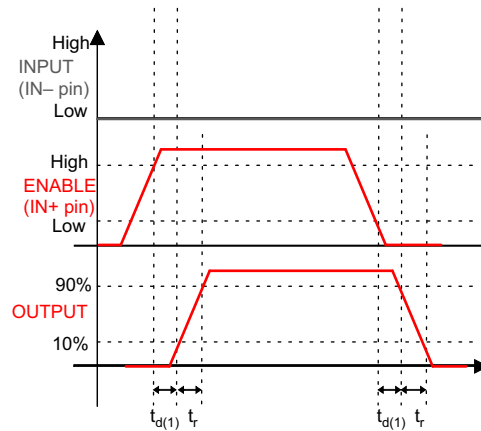
(1) See timing diagrams in [Figure 5-1](#), [Figure 5-2](#), [Figure 5-3](#), and [Figure 5-4](#).



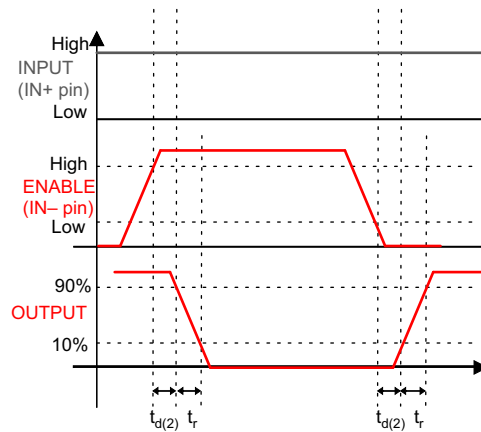
**Figure 5-1. Non-Inverting Configuration (PWM Input to IN+ pin (IN- Pin Tied to GND), Output Represents OUTH and OUTL Pins Tied Together in the UCC27511A)**



**Figure 5-2. Inverting Configuration (PWM Input to IN– Pin (IN+ Pin Tied to V<sub>DD</sub>), Output Represents OUTH and OUTL Pins Tied Together in the UCC27511A)**



**Figure 5-3. Enable And Disable Function Using IN+ Pin (Enable and Disable Signal Applied to IN+ Pin, PWM Input to IN– Pin, Output Represents OUTH and OUTL Pins Tied Together in the UCC27511A)**



**Figure 5-4. Enable and Disable Function Using IN– Pin (Enable and Disable Signal Applied to IN– Pin, PWM Input to IN+ Pin, Output Represents OUTH and OUTL Pins Tied Together in the UCC27511A)**



### 5.7 Typical Characteristics

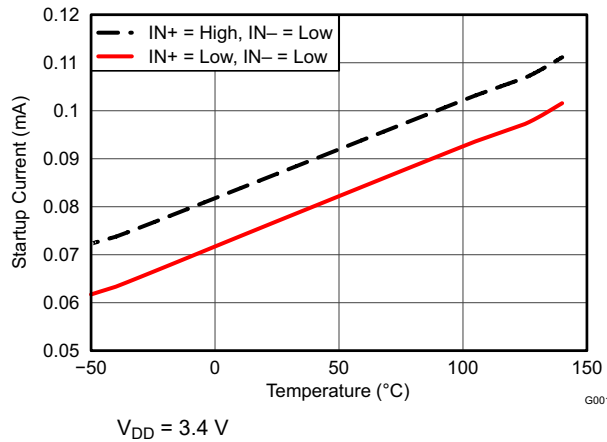


Figure 5-5. Startup Current vs Temperature

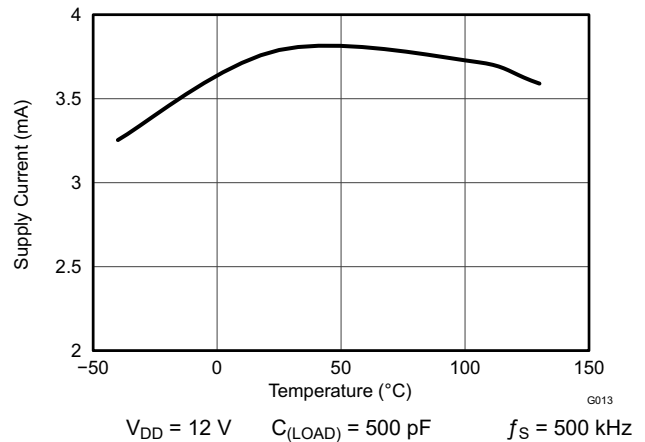


Figure 5-6. Operating Supply Current vs Temperature (Output Switching)

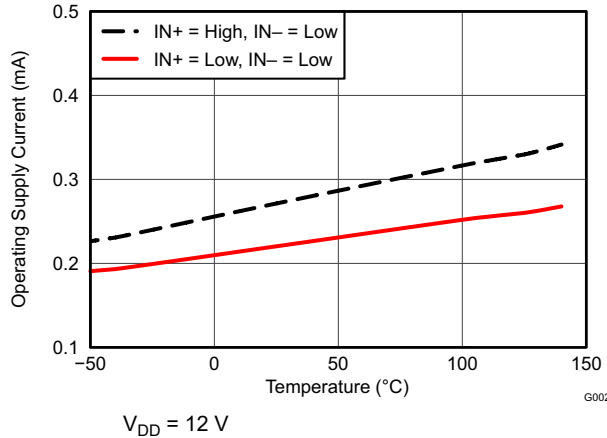


Figure 5-7. Supply Current vs Temperature (Output in DC On or Off Condition)

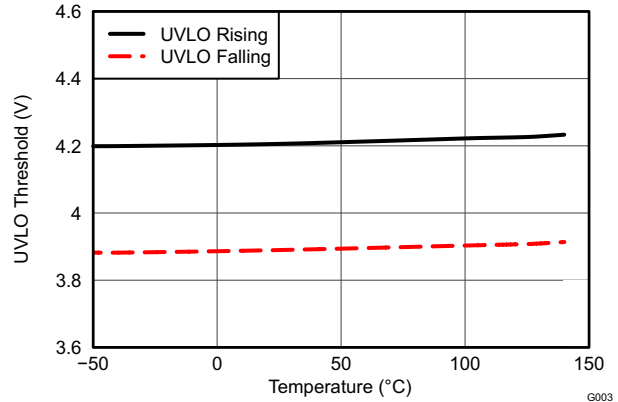


Figure 5-8. UVLO Threshold Voltage vs Temperature

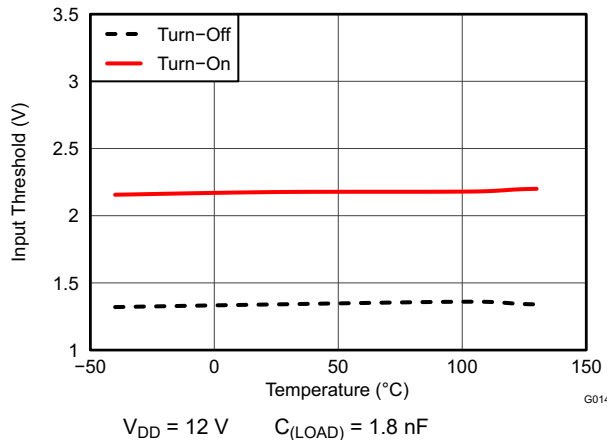


Figure 5-9. Input Threshold vs Temperature

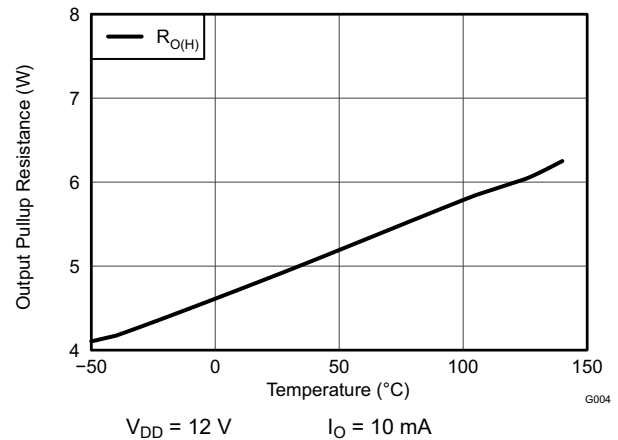
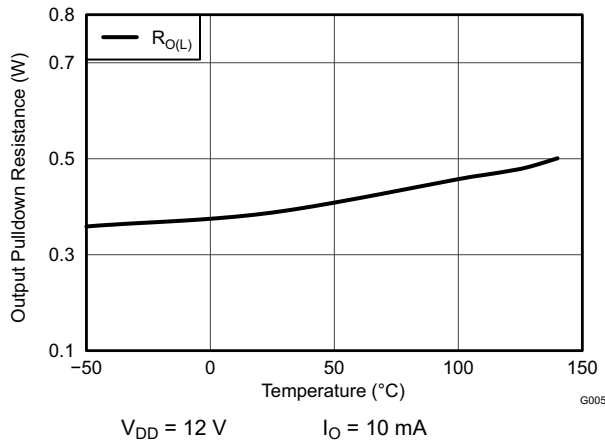
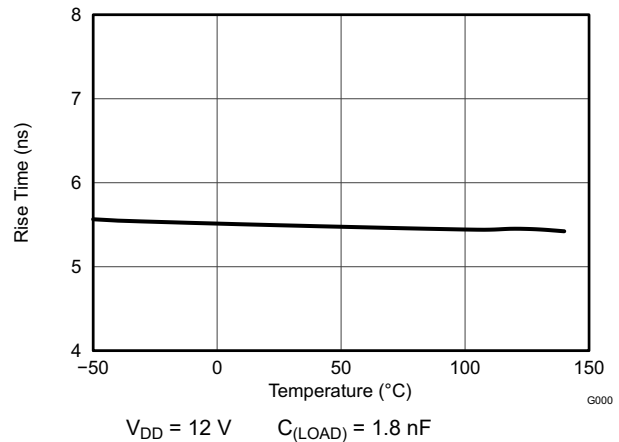


Figure 5-10. Output Pullup Resistance vs Temperature

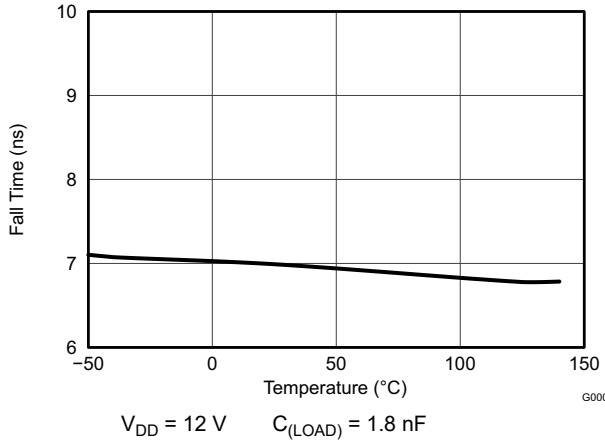
### 5.7 Typical Characteristics (continued)



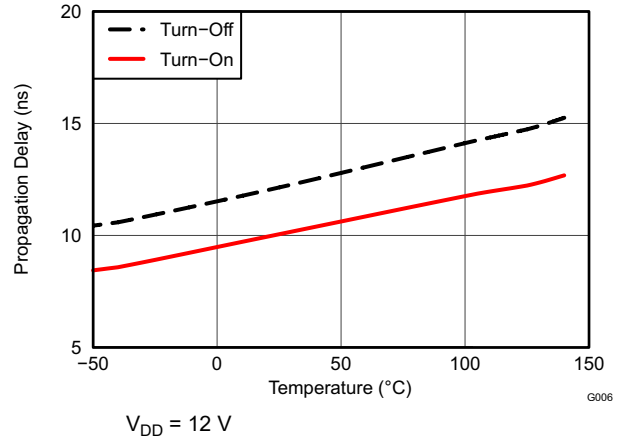
**Figure 5-11. Output Pull-Down Resistance vs Temperature**



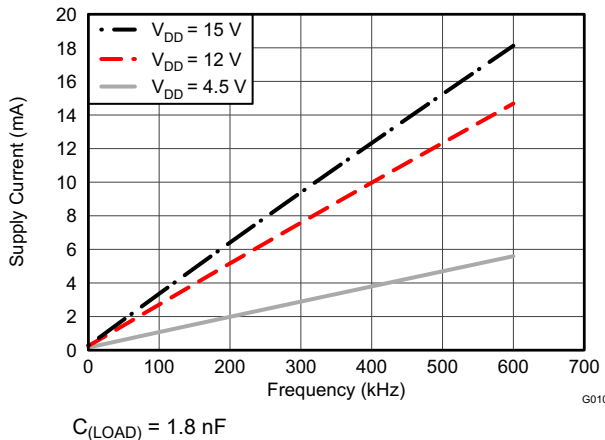
**Figure 5-12. Rise Time vs Temperature**



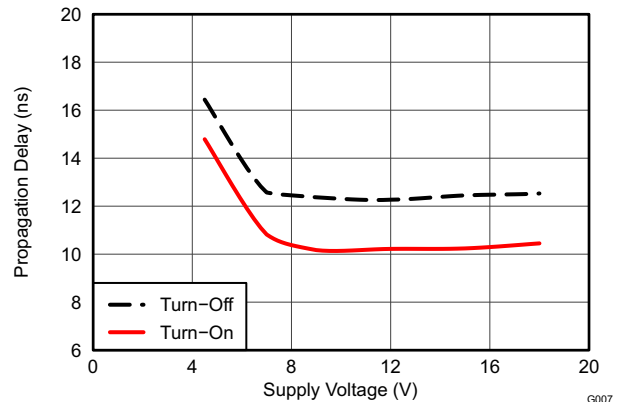
**Figure 5-13. Fall Time vs Temperature**



**Figure 5-14. Input to Output Propagation Delay vs Temperature**

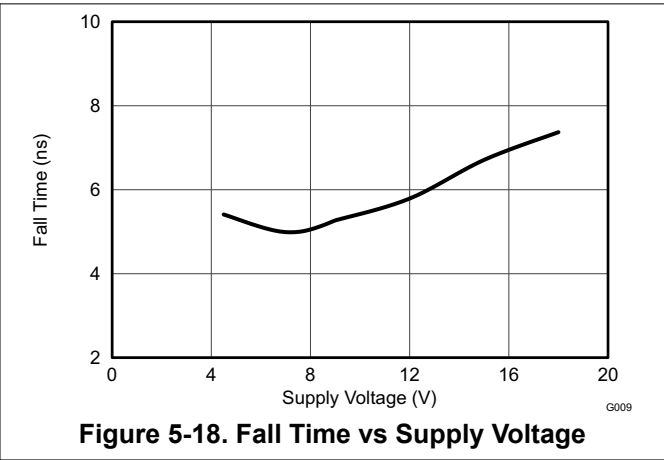
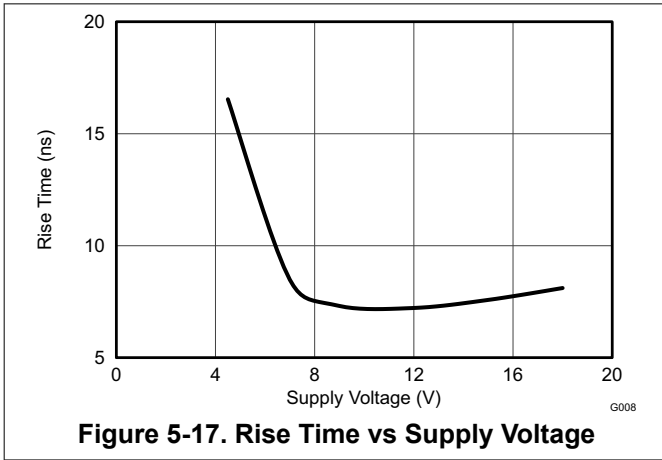


**Figure 5-15. Operating Supply Current vs Frequency**



**Figure 5-16. Propagation Delays vs Supply Voltage**

### 5.7 Typical Characteristics (continued)



## 6 Detailed Description

### 6.1 Overview

The UCC27511A single-channel high-speed low-side gate-driver device is capable of effectively driving MOSFET and IGBT power switches. Using a design that inherently minimizes shoot-through current, the UCC27511A device is capable of sourcing and sinking high peak-current pulses into capacitive loads offering rail-to-rail drive capability and extremely small propagation delay of 13 ns (typical).

The UCC27511A device provides 4-A source, 8-A sink (asymmetrical drive) peak-drive current capability. Strong sink capability in asymmetrical drive boosts immunity against parasitic, Miller turnon effect. The UCC27511A device also features a unique split output configuration where the gate-drive current is sourced through the OUTH pin and sunk through the OUTL pin. This unique pin arrangement allows the user to apply independent turnon and turnoff resistors to the OUTH and OUTL pins (respectively) and easily control the switching slew rates.

Alternatively the OUTH and OUTL pins can be tied together, which results in a typical gate driver output configuration where the source and sink currents are delivered from the same pin. In case of UCC27511A device, the state of the device's output is simply determined by the combined states of the OUTH and OUTL pins when tied together. Output high implies that OUTH pin is pulled close to  $V_{DD}$  pin bias voltage while OUTL pin is in high-impedance state. Similarly output low implies that OUTL pin is pulled close to the GND pin while OUTH pin is in high-impedance state. OUTH pulled to  $V_{DD}$ , while OUTL pulled to GND pin simultaneously is not a valid state for the device.

The UCC27511A device is designed to operate over a wide  $V_{DD}$  range of 4.5 to 18 V and wide temperature range of  $-40^{\circ}\text{C}$  to  $140^{\circ}\text{C}$ . Internal undervoltage lockout (UVLO) circuitry on the  $V_{DD}$  pin holds the output low outside  $V_{DD}$  operating range. The capability to operate at low voltage levels, such as below 5 V, along with best-in-class switching characteristics, is especially suited for driving emerging wide band-gap power-switching devices such as GaN power-semiconductor devices.

The UCC27511A device features a dual-input design which offers flexibility of implementing both inverting (IN– pin) and non-inverting (IN+ pin) configuration with the same device. Either the IN+ or IN– pin can be used to control the state of the driver output. The unused input pin can be used for enable and disable functions. For system robustness, internal pullup and pulldown resistors on the input pins ensure that outputs are held low when the input pins are in floating condition. Therefore the unused input pin is not left floating and must be properly biased to ensure that driver output is in enabled for normal operation.

The input pin threshold of the UCC27511A device is based on TTL and CMOS-compatible low-voltage logic which is fixed and independent of the  $V_{DD}$  supply voltage. Wide hysteresis between the high and low thresholds offers excellent noise immunity.

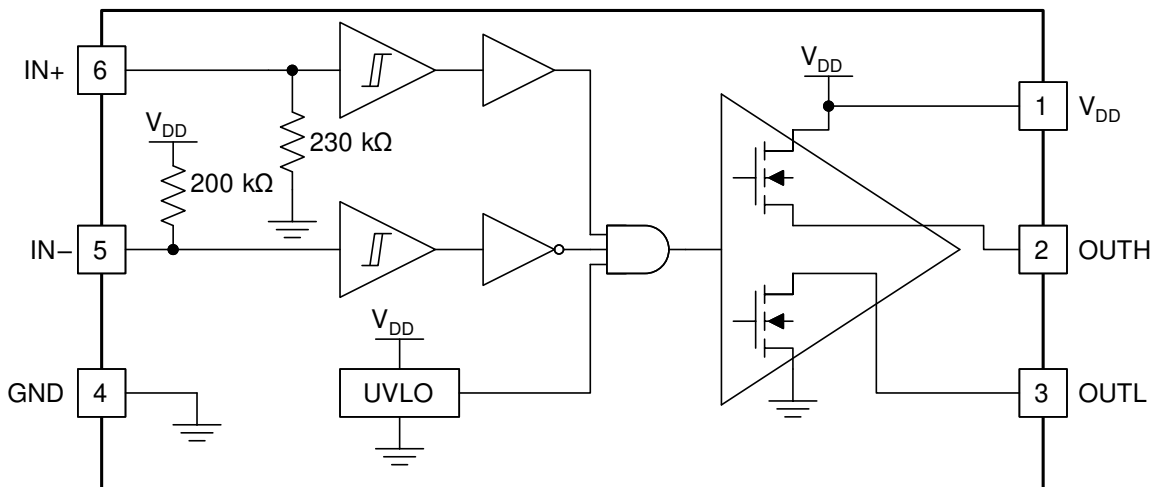
**Table 6-1. UCC27511A Device Summary**

PART NUMBER	PACKAGE	PEAK CURRENT (SOURCE, SINK)	INPUT THRESHOLD LOGIC
UCC27511ADB	SOT-23, 6 pin	4-A, 8-A (Asymmetrical Drive)	CMOS/TTL-Compatible (low voltage, independent of $V_{DD}$ bias voltage)

**Table 6-2. UCC27511A Features and Benefits**

FEATURE	BENEFIT
High source and sink current capability 4 A and 8 A (Asymmetrical) – UCC27511A device	High current capability offers flexibility in employing UCC2751x family of devices to drive a variety of power switching devices at varying speeds
best-in-class 13-ns (typ) propagation delay	Extremely low pulse-transmission distortion
Expanded $V_{DD}$ Operating range of 4.5 V to 18 V	Flexibility in system design
Expanded operating temperature range of $-40^{\circ}\text{C}$ to $140^{\circ}\text{C}$ (See the Section 5.5 table)	Low $V_{DD}$ operation ensures compatibility with emerging wide band-gap power devices such as GaN
$V_{DD}$ UVLO Protection	Outputs are held low in UVLO condition, which ensures predictable glitch-free operation at power up and power down
Outputs held low when input pins (INx) in floating condition	Enables the device to pass abnormal-condition system tests and delivers robust operation
Input pin voltage thresholds are independent of $V_{DD}$ . Input pins can withstand voltages greater than $V_{DD}$ .	System simplification, especially related to auxiliary bias supply architecture
Split output structure in the UCC27511A device (OUTH, OUTL)	Allows independent optimization of turnon and turnoff speeds
Strong sink current (8 A) and low pulldown impedance ( $0.375\ \Omega$ ) in the UCC27511A device	High immunity to $C \times dV/dt$ Miller turnon events
CMOS/TTL compatible input-threshold logic with wide hysteresis in the UCC27511A device	Enhanced noise immunity, while retaining compatibility with microcontroller logic-level input signals (3.3 V, 5 V) optimized for digital power

## 6.2 Functional Block Diagram



Copyright © 2018, Texas Instruments Incorporated

## 6.3 Feature Description

In the following sections, the term *output*, or *OUT* refers to the combined state that results when the OUTH pin is tied directly to the OUTL pin. As stated earlier, *output high*, or *OUT high* refers to the state when the OUTH pin is pulled close to  $V_{DD}$  pin bias voltage while the OUTL pin is in high-impedance state. Similarly *output low* or *OUT low* implies that the OUTL pin is pulled close to the GND pin while the OUTH pin is in high-impedance state.

### 6.3.1 $V_{DD}$ and Undervoltage Lockout

The UCC27511A device has an internal undervoltage-lockout (UVLO) protection feature on the  $V_{DD}$  pin supply circuit blocks. Whenever the driver is in UVLO condition (for example when the  $V_{DD}$  voltage is less than  $V_{(ON)}$  during power up and when the  $V_{DD}$  voltage is less than  $V_{(OFF)}$  during power down), this circuit holds all outputs low, regardless of the status of the inputs. The UVLO is typically 4.2 V with 300-mV typical hysteresis. This hysteresis prevents chatter when low  $V_{DD}$  supply voltages have noise from the power supply and also when there are droops in the  $V_{DD}$  bias voltage when the system commences switching and a sudden increase in  $I_{DD}$

occurs. The capability to operate at low voltage levels such as below 5 V, along with best-in-class switching characteristics, is especially suited for driving emerging GaN wide band-gap power-semiconductor devices.

For example, at power up, the UCC27511A driver output remains LOW until the  $V_{DD}$  voltage reaches the UVLO threshold. The magnitude of the OUT signal rises with  $V_{DD}$  until steady-state  $V_{DD}$  is reached. In the non-inverting operation (PWM signal applied to IN+ pin) shown in Figure 6-1, the output remains LOW until the UVLO threshold is reached, and then the output is IN-phase with the input. In the inverting operation (PWM signal applied to IN– pin) shown in Figure 6-2 the output remains low until the UVLO threshold is reached, and then the output is out-phase with the input. In both cases, the unused input pin must be properly biased to enable the output. Note that in these devices the output turns to high state only if the IN+ pin is high and the IN– pin is low after the UVLO threshold is reached.

Because the driver draws current from the  $V_{DD}$  pin to bias all internal circuits, for the best high-speed circuit performance, two  $V_{DD}$ -bypass capacitors are recommended to prevent noise problems. The use of surface-mount components is highly recommended. A 0.1- $\mu\text{F}$  ceramic capacitor should be located as close as possible to the  $V_{DD}$  to GND pins of the gate driver. In addition, to help deliver the high-current peaks required by the load, a larger capacitor (such as one with a value of 1  $\mu\text{F}$ ) with relatively low ESR should be connected in parallel and close proximity. The parallel combination of capacitors should present a low impedance characteristic for the expected current levels and switching frequencies in the application.

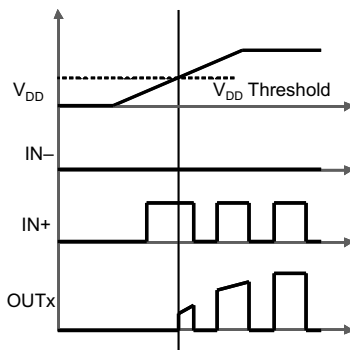


Figure 6-1. Power-Up (Non-Inverting Drive)

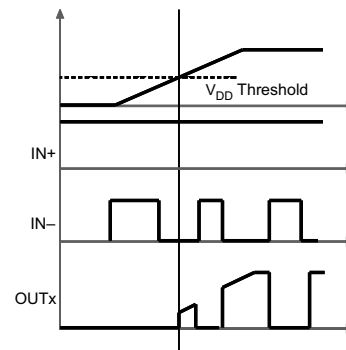


Figure 6-2. Power-Up (Inverting Drive)

### 6.3.2 Operating Supply Current

The UCC27511A device features very low quiescent  $I_{DD}$  currents. The typical operating-supply current in undervoltage-lockout (UVLO) state and fully-on state (under static and switching conditions) are summarized in Figure 5-5, Figure 5-6 and Figure 5-7. The  $I_{DD}$  current when the device is fully on and outputs are in a static state (DC high or DC low, refer Figure 5-7) represents lowest quiescent  $I_{DD}$  current when all the internal logic circuits of the device are fully operational. The total supply current is the sum of the quiescent  $I_{DD}$  current, the average  $I_O$  current because of switching, and finally any current related to pullup resistors on the unused input pin. For example, when the inverting input pin is pulled low additional current is drawn from the  $V_{DD}$  supply through the pullup resistors (see Section 6.2). Knowing the operating frequency ( $f_S$ ) and the MOSFET gate ( $Q_G$ ) charge at the drive voltage being used, the average  $I_O$  current can be calculated as product of  $Q_G$  and  $f_S$ .

A complete characterization of the  $I_{DD}$  current as a function of switching frequency at different  $V_{DD}$  bias voltages under 1.8-nF switching load is provided in Figure 5-15. The strikingly linear variation and close correlation with the theoretical value of the average  $I_O$  indicates negligible shoot-through inside the gate-driver device attesting to the high-speed characteristics.

### 6.3.3 Input Stage

The input pins of the UCC27511A device is based on a TTL and CMOS compatible input-threshold logic that is independent of the  $V_{DD}$  supply voltage. With a typically high threshold of 2.2 V and a typically low threshold of 1.2 V, the logic-level thresholds can be conveniently driven with PWM control signals derived from 3.3-V and 5-V digital-power controllers. Wider hysteresis (1 V typical) offers enhanced noise immunity compared to traditional

TTL-logic implementations, where the hysteresis is typically less than 0.5 V. This device also features tight control of the input-pin threshold-voltage levels which eases system design considerations and ensures stable operation across temperature. The very-low input capacitance on these pins reduces loading and increases switching speed.

Whenever any of the input pins are in a floating condition, the output of the respective channel is held in the low state. This function is achieved using  $V_{DD}$ -pullup resistors on all the inverting inputs (IN $-$  pin) or GND-pulldown resistors on all the non-inverting input pins (IN $+$  pin), (see [Section 6.2](#)).

The device also features a dual-input configuration with two input pins available to control the state of the output. The user has the flexibility to drive the device using either a non-inverting input pin (IN $+$ ) or an inverting input pin (IN $-$ ). The state of the output pin is dependent on the bias on both the IN $+$  and IN $-$  pins. For additional clarification, refer to the I/O-logic truth table ([Table 6-3](#)) and the typical application diagrams, ([Figure 6-4](#) and [Figure 6-5](#)).

When an input pin is selected for PWM drive, the other input pin (the *unused* input pin) must be properly biased in order to enable the output. As previously stated, the *unused* input pin cannot remain in a floating condition because whenever any input pin is left in a floating condition the output is disabled. Alternatively, the *unused* input pin can effectively be used to implement an enable or disable function. The following explains this function:

- In order to drive the device in a non-inverting configuration, apply the PWM-control input signal to IN $+$  pin. In this case, the *unused* input pin, IN $-$ , must be biased low (such as tied to GND) in order to enable the output.
  - Alternately, the IN $-$  pin is used to implement the enable or disable function using an external logic signal. OUT is disabled when IN $-$  is biased high and OUT is enabled when IN $-$  is biased low.
- In order to drive the device in an inverting configuration, apply the PWM-control input signal to IN $-$  pin. In this case, the *unused* input pin, IN $+$ , must be biased high (such as tied to  $V_{DD}$ ) in order to enable the output.
  - Alternately, the IN $+$  pin is used to implement the enable or disable function using an external logic signal. OUT is disabled when IN $+$  is biased low and OUT is enabled when IN $+$  is biased high.
- Finally, note that the output pin can be driven into a high state **only** when the IN $+$  pin is biased high and the IN $-$  input is biased low.

The input stage of the driver is preferably driven by a signal with a short rise or fall time. Use caution whenever the driver is used with slowly varying input signals, especially in situations where the device is located in a mechanical socket or PCB layout that is not optimal:

- High  $dI/dt$  current from the driver output coupled with board layout parasitics can cause ground bounce. The differential voltage between input pins and GND is modified and triggers an unintended change of output state because of fast 13-ns propagation delay which can ultimately result in high-frequency oscillations that increase power dissipation and pose a risk of damage to the device.
- A 1-V input-threshold hysteresis boosts noise immunity compared to most other industry standard drivers.
- In the worst case, when a slow input signal is used and PCB layout is not optimal, adding a small capacitor (1 nF) between the input pin and GND pin very close to the driver device may be necessary which helps to convert the differential mode noise with respect to the input-logic circuitry into common-mode noise and avoid unintended change of output state.

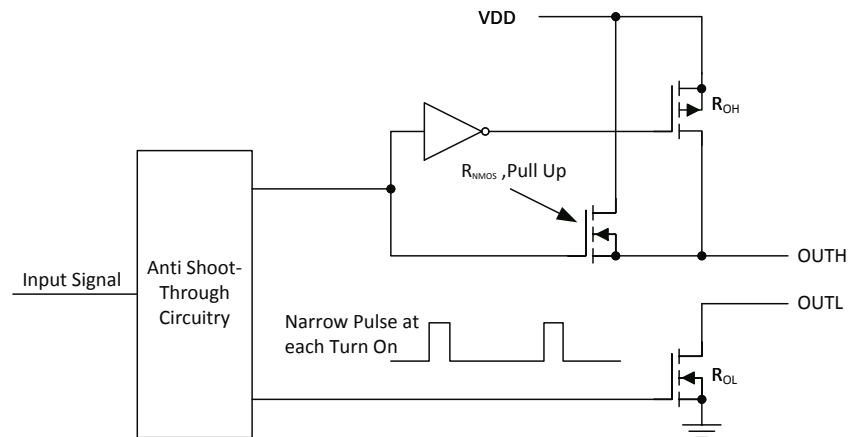
If limiting the rise or fall times to the power device is the primary goal, then an external resistance is highly recommended between the output of the driver and the power device instead of adding delays on the input signal. This external resistor has the additional benefit of reducing part of the gate-charge related power dissipation in the gate-driver device package and transferring the power dissipation into the external resistor.

### 6.3.4 Enable Function

As mentioned earlier, an enable and disable function is easily implemented in UCC27511A device using the *unused* input pin. When the IN $+$  pin is pulled down to GND or the IN $-$  pin is pulled down to  $V_{DD}$ , the output is disabled. Thus the IN $+$  pin can be used like an enable pin that is based on active-high logic, while the IN $-$  pin can be used like an enable pin that is based on active-low logic.

### 6.3.5 Output Stage

Figure 6-3 shows the output stage of the UCC27511A device. The UCC27511A device features a unique architecture on the output stage which delivers the highest peak-source current when the peak source current is most needed during the Miller plateau region of the power switch turnon transition (when the power-switch drain or collector voltage experiences  $dV/dt$ ). The device output stage features a hybrid pullup structure using a parallel arrangement of N-channel and P-channel MOSFET devices. By turning on the N-channel MOSFET during a narrow instant when the output changes state from low to high, the gate-driver device is able to deliver a brief boost in the peak-sourcing current enabling fast turnon.



**Figure 6-3. UCC27511A Gate Driver Output Structure**

The  $R_{O(H)}$  parameter (see the Section 5.5 table) is a DC measurement and is representative of the on-resistance of the P-channel device only, because the N-Channel device is turned on only during output change of state from low to high. Thus the effective resistance of the hybrid pullup stage is much lower than what is represented by  $R_{O(H)}$  parameter. The pulldown structure is composed of a N-channel MOSFET only. The  $R_{O(L)}$  parameter (see the Section 5.5 table), which is also a DC measurement, is representative of true impedance of the pulldown stage in the device. In the UCC27511A device, the effective resistance of the hybrid pullup structure is approximately  $2.7 \times R_{O(L)}$ .

The UCC27511A device features a unique split output configuration where the gate-drive current is sourced through the OUTH pin and sunk through the OUTL pin. This unique pin arrangement allows users to apply independent turnon and turnoff resistors to the OUTH and OUTL pins respectively and easily control the turnon and turnoff switching  $dV/dt$ . This pin arrangement, along with the low pulldown impedance of the output driver stage, is especially useful in applications where a high  $C \times dV/dt$  Miller turnon immunity is needed (such as with GaN power switches, SR MOSFETs and other applications) and the OUTL pin can be directly tied to the gate of the power device.



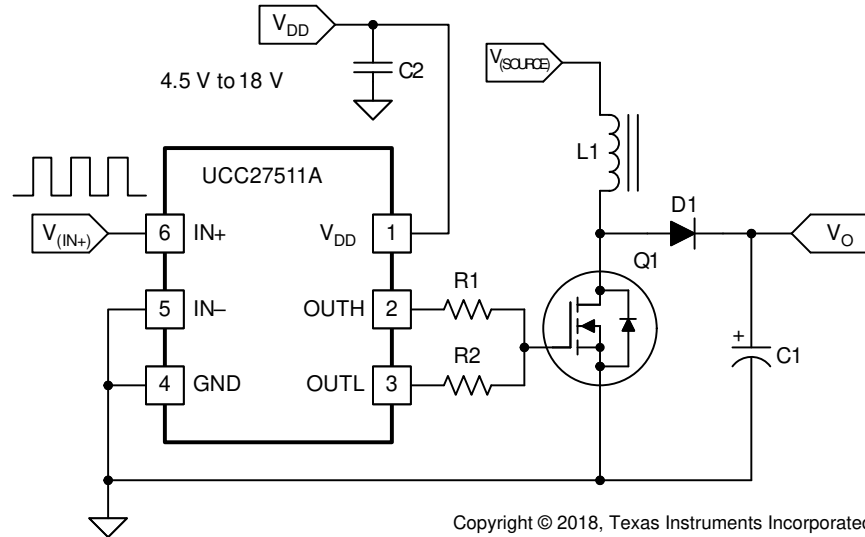


Figure 6-4. Using Non-Inverting Input (IN- Is Grounded To Enable Output)

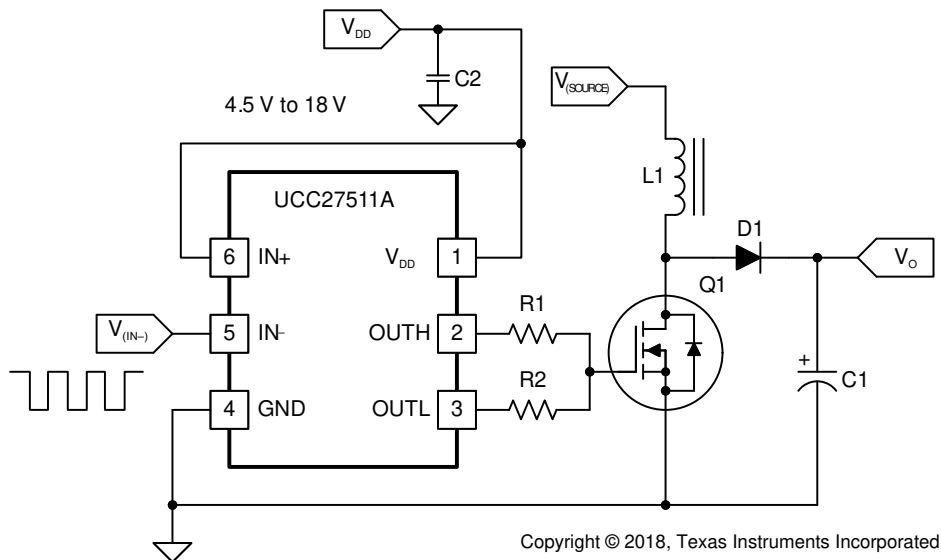
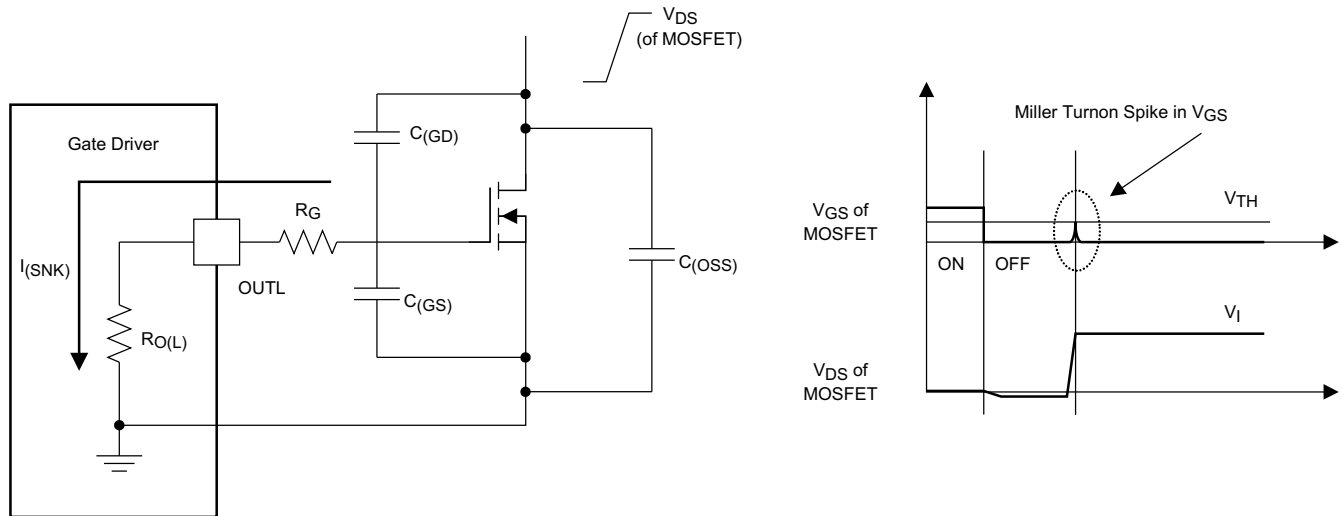


Figure 6-5. Using Inverting Input (IN+ Is Tied To V<sub>DD</sub> Enable Output)

The UCC27511A device is capable of delivering 4-A source, 8-A sink (asymmetrical drive) at  $V_{DD}$  equal to 12 V. Strong sink capability in asymmetrical drive results in a very-low pulldown impedance in the driver output stage which boosts immunity against parasitic, Miller turnon ( $C \times dV/dt$  turnon) effect, especially where the low gate-charge MOSFETs or emerging wide band-gap GaN-power switches are used.

An example of a situation where the Miller turnon effect is a concern is synchronous rectification (SR). In an SR application, the  $dV/dt$  occurs on the MOSFET drain when the MOSFET is already held in off state by the gate driver. The current discharging the  $C_{(GD)}$  Miller capacitance during this  $dV/dt$  is shunted by the pulldown stage of the driver. If the pulldown impedance is not low enough then a voltage spike can result in the  $V_{GS}$  of the MOSFET, which can result in spurious turnon. This phenomenon is shown in Figure 6-6. The UCC27511A device offers a best-in-class, 0.375- $\Omega$  (typ) pulldown impedance boosting immunity against Miller turnon.



**Figure 6-6. Very-Low Pull-down Impedance in UCC27511A, 4-A and 8-A Asymmetrical Drive (Output Stage Mitigates Miller Turnon Effect)**

The driver-output voltage swings between the  $V_{DD}$  and GND pins which provides rail-to-rail operation as a result of the MOS-output stage which delivers very-low dropout. The presence of the MOSFET-body diodes also offers low impedance to switching overshoots and undershoots. In many cases, external Schottky diode clamps are eliminated. The outputs of these drivers are designed to withstand 500-mA reverse current without either damage to the device or logic malfunction.

### 6.3.6 Low Propagation Delays

The UCC27511A driver device features best-in-class input-to-output propagation delay of 13 ns (typical) at  $V_{DD}$  equal to 12 V, which promises the lowest level of pulse transmission distortion available from industry-standard gate-driver devices for high-frequency switching applications. As shown in Figure 5-14, very little variation in propagation delay occurs with temperature and supply voltage, offering typically less than 20-ns propagation delays across the entire range of application conditions.

## 6.4 Device Functional Modes

The device operates in normal mode and UVLO mode. See Section 6.3.1 for information on UVLO operation mode. In the normal mode the output state is dependent on states of the IN+ and IN- pins. Table 6-3 lists the output states for different input pin combinations.

**Table 6-3. Device Logic Table**

IN+ PIN	IN- PIN	OUTH PIN	OUTL PIN	OUT (OUTH AND OUTL PINS TIED TOGETHER IN THE UCC27511A)
L	L	High impedance	L	L
L	H	High impedance	L	L
H	L	H	High impedance	H
H	H	High impedance	L	L
x <sup>(1)</sup>	Any	High impedance	L	L
Any	x <sup>(1)</sup>	High impedance	L	L

(1) x = Floating Condition

## 7 Application and Implementation

---

### Note

Information in the following applications sections is not part of the TI component specification, and TI does not warrant its accuracy or completeness. TI's customers are responsible for determining suitability of components for their purposes, as well as validating and testing their design implementation to confirm system functionality.

---

### 7.1 Application Information

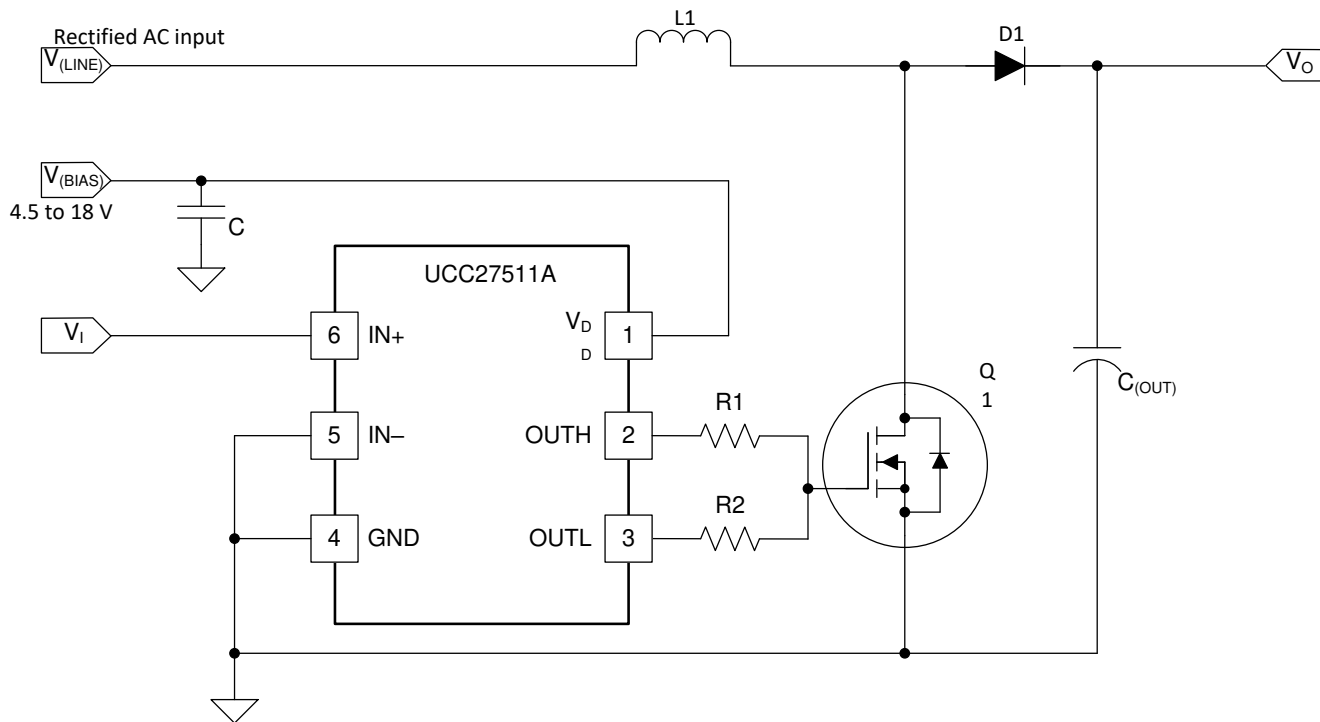
High-current gate-driver devices are required in switching-power applications for a variety of reasons. In order to effect fast switching of power devices and reduce associated switching power losses, a powerful gate driver employs between the PWM output of controllers and the gates of the power-semiconductor devices. Further, gate drivers are indispensable when having the PWM controller directly drive the gates of the switching devices is impossible. With the advent of digital power, this situation will be encountered often encountered because the PWM signal from the digital controller is often a 3.3-V logic signal which is not capable of effectively turning on a power switch.

A level-shifting circuitry is needed to boost the 3.3-V signal to the gate-drive voltage (such as 12 V) in order to fully turn on the power device and minimize conduction losses. Traditional buffer drive circuits based on NPN and PNP bipolar transistors in totem-pole arrangement, being emitter follower configurations, prove inadequate with digital power because these circuits lack level-shifting capability. Gate drivers effectively combine both the level-shifting and buffer-drive functions. Gate drivers also satisfy other needs such as minimizing the effect of high-frequency switching noise by locating the high-current driver physically close to the power switch, driving gate-drive transformers and controlling floating power-device gates, reducing power dissipation and thermal stress in controllers by moving gate charge power losses into the controller.

Finally, emerging wide bandgap power device technologies, such as GaN based switches, which are capable of supporting very high switching frequency operation, are driving very special requirements in terms of gate drive capability. These requirements include operation at low  $V_{DD}$  voltages (5 V or lower), low propagation delays and availability in compact, low-inductance packages with good thermal capability. In summary gate-driver devices are extremely important components in switching power combining benefits of high-performance low-cost component count and board-space reduction and simplified system design.

## 7.2 Typical Application

Figure 7-1 shows the typical application of UCC27511A device when used as a gate driver for the power MOSFET in a boost-converter application (for example, AC-DC power factor correction in AC-DC chargers for electric vehicles). In this application the UCC27511A device is used in the non-inverting input configuration.



Copyright © 2018, Texas Instruments Incorporated

**Figure 7-1. Typical Application in PFC Power Stage**

### 7.2.1 Design Requirements

When selecting the proper gate driver device for an end application, some design considerations must be evaluated first in order to make the most appropriate selection. Among these considerations are input-to-output configuration, the input threshold type, bias supply voltage levels, peak source and sink currents, availability of independent enable and disable functions, propagation delay, power dissipation, and package type.

### 7.2.2 Detailed Design Procedure

#### 7.2.2.1 Input-to-Output Logic

The design should specify which type of input-to-output configuration should be used. If turning on the power MOSFET or IGBT when the input signal is in high state is preferred, then the non-inverting configuration must be selected. If turning off the power MOSFET or IGBT when the input signal is in high state is preferred, the inverting configuration must be chosen. The UCC27511A device can be configured in either an inverting or non-inverting input-to-output configuration using the IN– or IN+ pins respectively. To configure the device for use in inverting mode, tie the IN+ pin to  $V_{DD}$  and apply the input signal to the IN– pin. For the non-inverting configuration, tie the IN– pin to GND and apply the input signal to the IN+ pin.

#### 7.2.2.2 Input Threshold Type

The type of Input voltage threshold determines the type of controller that can be used with the gate driver device. The UCC27511A device features a TTL and CMOS-compatible input threshold logic, with wide hysteresis. The threshold voltage levels are low voltage and independent of the  $V_{DD}$  supply voltage, which allows compatibility with both logic-level input signals from microcontrollers as well as higher-voltage input signals from analog

controllers. See the [Section 5.5](#) table for the actual input threshold voltage levels and hysteresis specifications for the UCC27511A device.

### 7.2.2.3 $V_{DD}$ Bias Supply Voltage

The bias supply voltage to be applied to the  $V_{DD}$  pin of the device should never exceed the values listed in the [Section 5.3](#) table. However, different power switches demand different voltage levels to be applied at the gate terminals for effective turnon and turnoff. With certain power switches, a positive gate voltage may be required for turnon and a negative gate voltage may be required for turnoff, in which case the  $V_{DD}$  bias supply equals the voltage differential. With a wide operating range from 4.5 V to 18 V, the UCC27511A device can be used to drive a variety of power switches, such as Si MOSFETs (for example,  $V_{GS} = 4.5$  V, 10 V, 12 V), IGBTs ( $V_{GE} = 15$  V, 18 V), and wide-bandgap power semiconductors (such as GaN, certain types of which allow no higher than 6 V to be applied to the gate terminals).

### 7.2.2.4 Peak Source and Sink Currents

Generally, switching the speed of the power switch during turnon and turnoff should be as fast as possible in order to minimize switching power losses. The gate driver device must be able to provide the required peak current for achieving the targeted switching speeds for the targeted power MOSFET.

Using the example of a power MOSFET, the system requirement for the switching speed is typically described in terms of the slew rate of the drain-to-source voltage of the power MOSFET (such as  $dV_{DS}/dt$ ). For example, the system requirement might state that a SPP20N60C3 power MOSFET must be turned-on with a  $dV_{DS}/dt$  of 20 V/ns or higher under a DC bus voltage of 400 V in a continuous-conduction-mode (CCM) boost PFC-converter application. This type of application is an inductive hard-switching application and reducing switching power losses is critical. This requirement means that the entire drain-to-source voltage swing during power MOSFET turn-on event (from 400 V in the OFF state to  $V_{DS(on)}$  in on state) must be completed in approximately 20 ns or less. When the drain-to-source voltage swing occurs, the Miller charge of the power MOSFET ( $Q_{GD}$  parameter in SPP20N60C3 power MOSFET data sheet = 33 nC typical) is supplied by the peak current of gate driver. According to power MOSFET inductive switching mechanism, the gate-to-source voltage of the power MOSFET at this time is the Miller plateau voltage, which is typically a few volts higher than the threshold voltage of the power MOSFET,  $V_{GS(TH)}$ .

In order to achieve the targeted  $dV_{DS}/dt$ , the gate driver must be capable of providing the  $Q_{GD}$  charge in 20 ns or less. In other words a peak current of 1.65 A (= 33 nC / 20 ns) or higher must be provided by the gate driver. The UCC27511A gate driver is capable of providing 4-A peak sourcing current which clearly exceeds the design requirement and has the capability to meet the switching speed needed. The 2.4x overdrive capability provides an extra margin against part-to-part variations in the  $Q_{GD}$  parameter of the power MOSFET along with additional flexibility to insert external gate resistors and fine tune the switching speed for efficiency versus EMI optimizations.

However, in practical designs the parasitic trace inductance in the gate drive circuit of the PCB will have a definitive role to play on the power MOSFET switching speed. The effect of this trace inductance is to limit the  $di/dt$  of the output current pulse of the gate driver. In order to illustrate this, consider output current pulse waveform from the gate driver to be approximated to a triangular profile, where the area under the triangle ( $\frac{1}{2} \times I_{PEAK} \times \text{time}$ ) would equal the total gate charge of the power MOSFET ( $Q_G$  parameter in SPP20N60C3 power MOSFET datasheet = 87 nC typical). If the parasitic trace inductance limits the  $di/dt$  then a situation may occur in which the full peak current capability of the gate driver is not fully achieved in the time required to deliver the  $Q_G$  required for the power MOSFET switching. In other words the time parameter in the equation would dominate and the  $I_{PEAK}$  value of the current pulse would be much less than the true peak current capability of the device, while the required  $Q_G$  is still delivered. Because of this, the desired switching speed may not be realized, even when theoretical calculations indicate the gate driver is capable of achieving the targeted switching speed. Thus, placing the gate driver device very close to the power MOSFET and designing a tight gate drive-loop with minimal PCB trace inductance is important to realize the full peak-current capability of the gate driver.

### 7.2.2.5 Enable and Disable Function

Certain applications demand independent control of the output state of the driver without involving the input signal. A pin which offers an enable and disable function achieves this requirement. The UCC27511A device offers 2 input pins, IN+ and IN–, both of which control the state of the output as listed in [Table 6-3](#). Based on whether an inverting or non-inverting input signal is provided to the driver, the appropriate input pin can be selected as the primary input for controlling the gate driver. The other *unused* input pin can be conveniently used for the enable and disable functionality. If the design does not require an enable function, the unused input pin can be tied to either the V<sub>DD</sub> pin (in case IN+ is the unused pin), or GND (in case IN– is unused pin) in order to ensure it does not affect the output status.

### 7.2.2.6 Propagation Delay

The acceptable propagation delay from the gate driver is dependent on the switching frequency at which it is used and the acceptable level of pulse distortion to the system. The UCC27511A device features industry best-in-class 13-ns (typical) propagation delays which ensures very little pulse distortion and allows operation at very high-frequencies. See the [Section 5.6](#) table for the propagation and switching characteristics of the UCC27511A device.

### 7.2.2.7 Thermal Information

The useful range of a driver is greatly affected by the drive-power requirements of the load and the thermal characteristics of the package. In order for a gate driver to be useful over a particular temperature range the package must allow for the efficient removal of the heat produced while keeping the junction temperature within rated limits. The thermal metrics for the driver package is listed in the [Section 5.4](#) table. For detailed information regarding the [Section 5.4](#) table, refer to the Application Note from Texas Instruments entitled [IC Package Thermal Metrics](#).

The UCC27511A device is offered in a SOT-23, 6-pin package (DBV). [Section 5.4](#) lists the thermal performance metrics related to SOT-23 package. The  $\psi_{JT}$  and  $\psi_{JB}$  metrics are used when estimating the die temperature during actual application measurements.

Heat removal occurs primarily through the leads of the device and the PCB traces connected to the leads.

### 7.2.2.8 Power Dissipation

Power dissipation of the gate driver has two portions as shown in [Equation 1](#).

$$P_D = P_{D(DC)} + P_{D(SW)} \quad (1)$$

where

- $P_D$  is the power dissipation
- $P_{D(DC)}$  is the DC portion of the power dissipation
- $P_{D(SW)}$  is the power dissipated in the gate-driver package during switching

Use [Equation 2](#) to calculate the DC portion of the power dissipation.

$$P_{P(DC)} = I_Q \times V_{DD} \quad (2)$$

where

- $I_Q$  is the quiescent current for the driver

The quiescent current is the current consumed by the device to bias all internal circuits such as input stage, reference voltage, logic circuits, protections, and also any current associated with switching of internal devices when the driver output changes state (such as charging and discharging of parasitic capacitances, parasitic shoot-through, and others). The UCC27511A device features very low quiescent currents (less than 1 mA, see [Figure 5-7](#)) and contains internal logic to eliminate any shoot-through in the output driver stage. Thus the effect of the  $P_{D(DC)}$  on the total power dissipation within the gate driver can be assumed to be negligible.

The power dissipated in the gate-driver package during switching ( $P_{D(SW)}$ ) depends on the following factors:

- The gate charge required of the power device (usually a function of the drive voltage  $V_G$ , which is very close to input bias supply voltage  $V_{DD}$  because of low  $V_{O(H)}$  drop-out).
- The switching frequency ( $f_S$ )
- Use of external gate resistors ( $R_{(GATE)}$ )

When a driver device is tested with a discrete, capacitive load calculating the power that is required from the bias supply is fairly simple. The energy to charge the capacitor is given by [Equation 3](#).

$$E_G = \frac{1}{2} C_{(LOAD)} \times V_{DD}^2 \quad (3)$$

Where

- $C_{(LOAD)}$  is load capacitor
- $V_{DD}$  is bias voltage feeding the driver
- $E_G$  is the energy stored in the capacitor when it is charged to  $V_{DD}$

An equal amount of energy dissipates when the capacitor is charged which leads to a total power loss given by [Equation 4](#).

$$P_{tot} = C_{(LOAD)} \times V_{DD}^2 \times f_S \quad (4)$$

where

- $P_{tot}$  is the total power loss
- $f_S$  is the switching frequency

The switching load presented by a power MOSFET or IGBT is converted to an equivalent capacitance by examining the gate charge required to switch the device. This gate charge includes the effects of the input capacitance plus the added charge needed to swing the drain voltage of the power device as it switches

between the ON and OFF states. Most manufacturers provide specifications of typical and maximum gate charge, in nC, to switch the device under specified conditions. Using the gate charge,  $Q_G$ , determine the power that must be dissipated when charging a capacitor (calculated using Equation 5, to provide Equation 6).

$$Q_G = C_{(LOAD)} \times V_{DD} \tag{5}$$

$$P_{tot} = C_{(LOAD)} \times V_{DD}^2 \times f_S = Q_G \times V_{DD} \times f_S \tag{6}$$

This power,  $P_{tot}$ , is dissipated in the resistive elements of the circuit when the MOSFET or IGBT is being turned on or off. Half of the total power is dissipated when the load capacitor is charged during turnon, and the other half is dissipated when the load capacitor is discharged during turnoff. When no external gate resistor is employed between the driver and MOSFET or IGBT, this power is completely dissipated inside the driver package. With the use of external gate-drive resistors, the power dissipation is shared between the internal resistance of driver and external gate resistor in accordance to the ratio of the resistance (more power dissipated in the higher resistance component). Based on this simplified analysis, the driver power dissipation during switching is calculated in Equation 7.

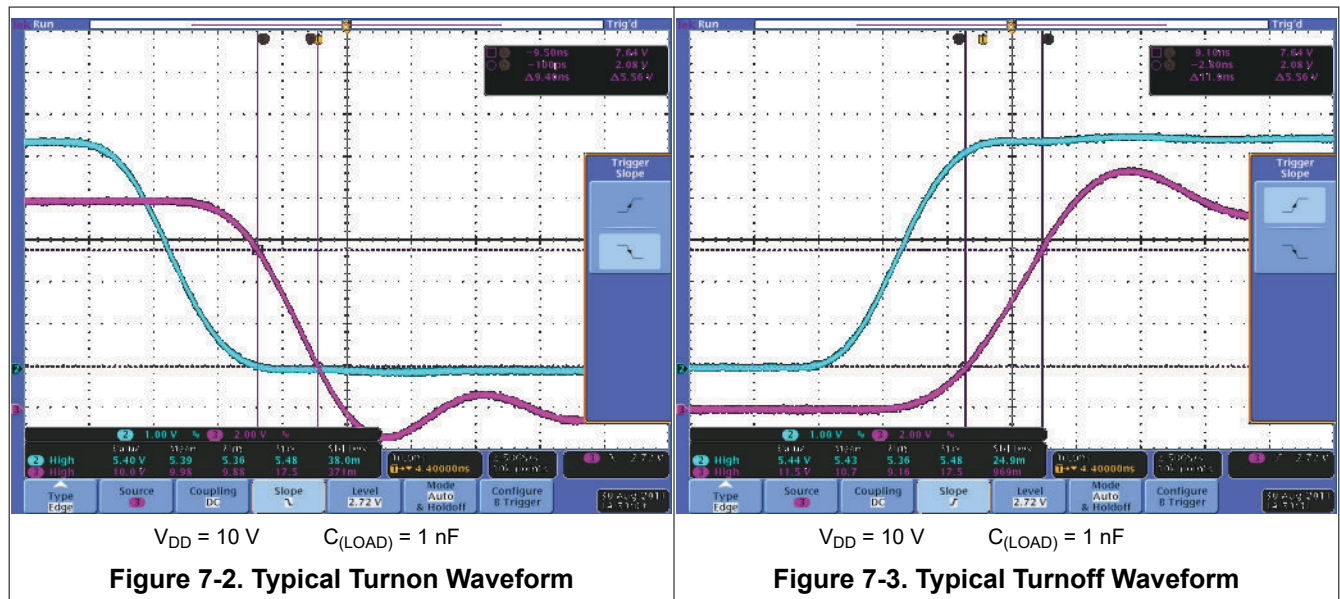
$$P_{D(SW)} = 0.5 \times Q_G \times V_{DD} \times f_S \times \left( \frac{R_{(OFF)}}{R_{(OFF)} + R_{(GATE)}} + \frac{R_{(ON)}}{R_{(ON)} + R_{(GATE)}} \right) \tag{7}$$

where

- $R_{(OFF)} = R_{O(L)}$
- $R_{(ON)}$  (effective resistance of pullup structure) =  $2.7 \times R_{O(L)}$

### 7.2.3 Application Curves

Figure 7-2 and Figure 7-3 show the typical switching characteristics of the UCC27511A device.





## 8 Power Supply Recommendations

The bias supply voltage range for which the UCC27511A device is rated to operate is from 4.5 V to 18 V. The lower end of this range is governed by the internal undervoltage-lockout (UVLO) protection feature on the  $V_{DD}$  pin supply circuit blocks. Whenever the driver is in UVLO condition when the  $V_{DD}$  pin voltage is below the  $V_{(ON)}$  supply start threshold, this feature holds the output low, regardless of the status of the inputs. The upper end of this range is driven by the 20-V absolute maximum voltage rating of the  $V_{DD}$  pin of the device (which is a stress rating). Keeping a 2-V margin to allow for transient voltage spikes, the maximum recommended voltage for the  $V_{DD}$  pin is 18 V.

The UVLO protection feature also involves a hysteresis function. This means that when the  $V_{DD}$  pin bias voltage has exceeded the threshold voltage and device begins to operate, and if the voltage drops, then the device continues to deliver normal functionality unless the voltage drop exceeds the hysteresis specification  $V_{DD(hys)}$ . Therefore, ensuring that, while operating at or near the 4.5V range, the voltage ripple on the auxiliary power supply output is smaller than the hysteresis specification of the device is important to avoid triggering device shutdown.

During system shutdown, the device operation continues until the  $V_{DD}$  pin voltage has dropped below the  $V_{(OFF)}$  threshold which must be accounted for while evaluating system shutdown timing design requirements. Likewise, at system startup, the device does not begin operation until the  $V_{DD}$  pin voltage has exceeded above the  $V_{(ON)}$  threshold.

The quiescent current consumed by the internal circuit blocks of the device is supplied through the  $V_{DD}$  pin. Although this fact is well known, recognizing that the charge for source current pulses delivered by the OUTH pin is also supplied through the same  $V_{DD}$  pin is important. As a result, every time a current is sourced out of the output pins (OUTH), a corresponding current pulse is delivered into the device through the  $V_{DD}$  pin. Thus ensuring that local bypass capacitors are provided between the  $V_{DD}$  and GND pins and located as close to the device as possible for the purpose of decoupling is important. A low ESR, ceramic surface mount capacitor is a must. TI recommends to have 2 capacitors; a 100-nF ceramic surface-mount capacitor which can be nudged very close to the pins of the device and another surface-mount capacitor of few microfarads added in parallel.

## 9 Layout

### 9.1 Layout Guidelines

Proper PCB layout is extremely important in a high-current fast-switching circuit to provide appropriate device operation and design robustness. The UCC27511A gate driver incorporates short-propagation delays and powerful output stages capable of delivering large current peaks with very fast rise and fall times at the gate of power switch to facilitate voltage transitions very quickly. At higher  $V_{DD}$  voltages, the peak-current capability is even higher (4-A/8-A peak current is at  $V_{DD}$  equal to 12 V). Very high  $di/dt$  causes unacceptable ringing if the trace lengths and impedances are not well controlled. The following circuit-layout guidelines are strongly recommended when designing with these high-speed drivers.

- Place the driver device as close as possible to power device in order to minimize the length of high-current traces between the output pins and the gate of the power device.
- Place the  $V_{DD}$ -bypass capacitors between the  $V_{DD}$  pin and GND as close as possible to the driver with minimal trace length to improve the noise filtering. These capacitors support high-peak current being drawn from  $V_{DD}$  during turnon of power MOSFET. The use of low inductance surface-mount components such as chip resistors and chip capacitors is highly recommended.
- The turnon and turnoff current-loop paths (driver device, power MOSFET, and  $V_{DD}$  bypass capacitor) should be minimized as much as possible in order to keep the stray inductance to a minimum. High  $di/dt$  is established in these loops at two instances – during turnon and turnoff transients, which will induce significant voltage transients on the output pin of the driver device and gate of the power switch.
- Wherever possible, parallel the source and return traces, taking advantage of flux cancellation.
- Separate power traces and signal traces, such as the output and input signals.
- Minimize noise coupling from one current loop to another with star-point grounding or other techniques. The GND of the driver should be connected to the other circuit nodes such as source of power switch, ground of PWM controller, and others at one single point. The connected paths should be as short as possible to reduce inductance and be as wide as possible to reduce resistance.
- Use a ground plane to provide noise shielding. Fast rise and fall times at OUT may corrupt the input signals during transition. The ground plane must not be a conduction path for any current loop. Instead the ground plane must be connected to the star-point with one single trace to establish the ground potential. In addition to noise shielding, the ground plane can help in power dissipation as well.
- In noisy environments, tying the unused Input pin of UCC27511A device to the  $V_{DD}$  (in case of IN+) pin or GND (in case of IN–) using short traces in order to ensure that the output is enabled and to prevent noise from causing malfunction in the output may be necessary.

### 9.2 Layout Example

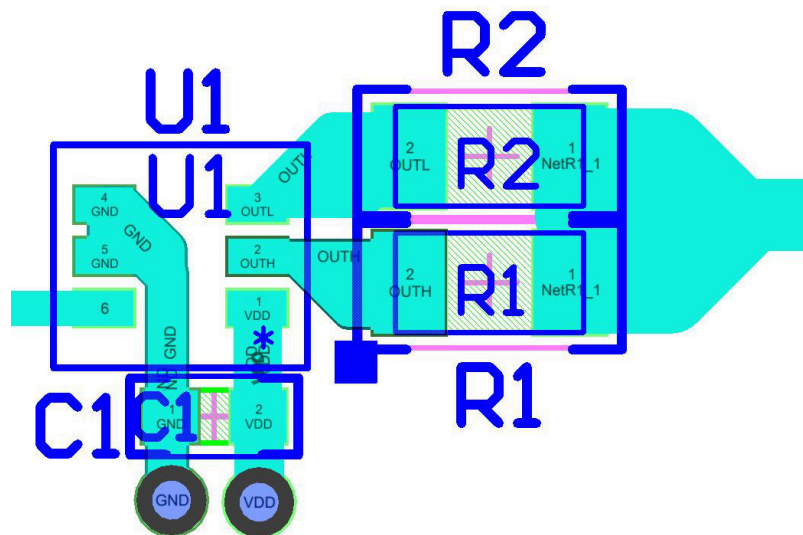


Figure 9-1. UCC27511A Layout Example

## 10 Device and Documentation Support

### 10.1 Device Support

#### 10.1.1 Third-Party Products Disclaimer

TI'S PUBLICATION OF INFORMATION REGARDING THIRD-PARTY PRODUCTS OR SERVICES DOES NOT CONSTITUTE AN ENDORSEMENT REGARDING THE SUITABILITY OF SUCH PRODUCTS OR SERVICES OR A WARRANTY, REPRESENTATION OR ENDORSEMENT OF SUCH PRODUCTS OR SERVICES, EITHER ALONE OR IN COMBINATION WITH ANY TI PRODUCT OR SERVICE.

#### 10.2 Receiving Notification of Documentation Updates

To receive notification of documentation updates, navigate to the device product folder on [ti.com](https://www.ti.com). Click on *Notifications* to register and receive a weekly digest of any product information that has changed. For change details, review the revision history included in any revised document.

#### 10.3 Support Resources

[TI E2E™ support forums](#) are an engineer's go-to source for fast, verified answers and design help — straight from the experts. Search existing answers or ask your own question to get the quick design help you need.

Linked content is provided "AS IS" by the respective contributors. They do not constitute TI specifications and do not necessarily reflect TI's views; see TI's [Terms of Use](#).

#### 10.4 Trademarks

TI E2E™ is a trademark of Texas Instruments.  
All trademarks are the property of their respective owners.

#### 10.5 Electrostatic Discharge Caution



This integrated circuit can be damaged by ESD. Texas Instruments recommends that all integrated circuits be handled with appropriate precautions. Failure to observe proper handling and installation procedures can cause damage.

ESD damage can range from subtle performance degradation to complete device failure. Precision integrated circuits may be more susceptible to damage because very small parametric changes could cause the device not to meet its published specifications.

#### 10.6 Glossary

[TI Glossary](#) This glossary lists and explains terms, acronyms, and definitions.

## 11 Revision History

NOTE: Page numbers for previous revisions may differ from page numbers in the current version.

<b>Changes from Revision * (March 2018) to Revision A (January 2024)</b>	<b>Page</b>
• Changed rise time in Features from 9ns to 8ns .....	<b>1</b>

## 12 Mechanical, Packaging, and Orderable Information

The following pages include mechanical, packaging, and orderable information. This information is the most current data available for the designated devices. This data is subject to change without notice and revision of this document. For browser-based versions of this data sheet, refer to the left-hand navigation.

**PACKAGING INFORMATION**

Orderable Device	Status (1)	Package Type	Package Drawing	Pins	Package Qty	Eco Plan (2)	Lead finish/ Ball material (6)	MSL Peak Temp (3)	Op Temp (°C)	Device Marking (4/5)	Samples
UCC27511ADBVR	ACTIVE	SOT-23	DBV	6	3000	RoHS & Green	NIPDAU	Level-2-260C-1 YEAR	-40 to 140	511A	Samples
UCC27511ADBVT	ACTIVE	SOT-23	DBV	6	250	RoHS & Green	NIPDAU	Level-2-260C-1 YEAR	-40 to 140	511A	Samples

(1) The marketing status values are defined as follows:

**ACTIVE:** Product device recommended for new designs.

**LIFEBUY:** TI has announced that the device will be discontinued, and a lifetime-buy period is in effect.

**NRND:** Not recommended for new designs. Device is in production to support existing customers, but TI does not recommend using this part in a new design.

**PREVIEW:** Device has been announced but is not in production. Samples may or may not be available.

**OBSOLETE:** TI has discontinued the production of the device.

(2) **RoHS:** TI defines "RoHS" to mean semiconductor products that are compliant with the current EU RoHS requirements for all 10 RoHS substances, including the requirement that RoHS substance do not exceed 0.1% by weight in homogeneous materials. Where designed to be soldered at high temperatures, "RoHS" products are suitable for use in specified lead-free processes. TI may reference these types of products as "Pb-Free".

**RoHS Exempt:** TI defines "RoHS Exempt" to mean products that contain lead but are compliant with EU RoHS pursuant to a specific EU RoHS exemption.

**Green:** TI defines "Green" to mean the content of Chlorine (Cl) and Bromine (Br) based flame retardants meet JS709B low halogen requirements of <=1000ppm threshold. Antimony trioxide based flame retardants must also meet the <=1000ppm threshold requirement.

(3) MSL, Peak Temp. - The Moisture Sensitivity Level rating according to the JEDEC industry standard classifications, and peak solder temperature.

(4) There may be additional marking, which relates to the logo, the lot trace code information, or the environmental category on the device.

(5) Multiple Device Markings will be inside parentheses. Only one Device Marking contained in parentheses and separated by a "~" will appear on a device. If a line is indented then it is a continuation of the previous line and the two combined represent the entire Device Marking for that device.

(6) Lead finish/Ball material - Orderable Devices may have multiple material finish options. Finish options are separated by a vertical ruled line. Lead finish/Ball material values may wrap to two lines if the finish value exceeds the maximum column width.

**Important Information and Disclaimer:**The information provided on this page represents TI's knowledge and belief as of the date that it is provided. TI bases its knowledge and belief on information provided by third parties, and makes no representation or warranty as to the accuracy of such information. Efforts are underway to better integrate information from third parties. TI has taken and continues to take reasonable steps to provide representative and accurate information but may not have conducted destructive testing or chemical analysis on incoming materials and chemicals. TI and TI suppliers consider certain information to be proprietary, and thus CAS numbers and other limited information may not be available for release.

In no event shall TI's liability arising out of such information exceed the total purchase price of the TI part(s) at issue in this document sold by TI to Customer on an annual basis.

**OTHER QUALIFIED VERSIONS OF UCC27511A :**

- Automotive : [UCC27511A-Q1](#)

## NOTE: Qualified Version Definitions:

- Automotive - Q100 devices qualified for high-reliability automotive applications targeting zero defects

**TAPE AND REEL INFORMATION**

**QUADRANT ASSIGNMENTS FOR PIN 1 ORIENTATION IN TAPE**


\*All dimensions are nominal

Device	Package Type	Package Drawing	Pins	SPQ	Reel Diameter (mm)	Reel Width W1 (mm)	A0 (mm)	B0 (mm)	K0 (mm)	P1 (mm)	W (mm)	Pin1 Quadrant
UCC27511ADBVR	SOT-23	DBV	6	3000	178.0	9.0	3.23	3.17	1.37	4.0	8.0	Q3
UCC27511ADBVT	SOT-23	DBV	6	250	178.0	9.0	3.23	3.17	1.37	4.0	8.0	Q3

**TAPE AND REEL BOX DIMENSIONS**


\*All dimensions are nominal

Device	Package Type	Package Drawing	Pins	SPQ	Length (mm)	Width (mm)	Height (mm)
UCC27511ADBVR	SOT-23	DBV	6	3000	180.0	180.0	18.0
UCC27511ADBVT	SOT-23	DBV	6	250	180.0	180.0	18.0





# EXAMPLE BOARD LAYOUT

DBV0006A

SOT-23 - 1.45 mm max height

SMALL OUTLINE TRANSISTOR



LAND PATTERN EXAMPLE  
EXPOSED METAL SHOWN  
SCALE:15X



SOLDER MASK DETAILS

4214840/G 08/2024

NOTES: (continued)

- 6. Publication IPC-7351 may have alternate designs.
- 7. Solder mask tolerances between and around signal pads can vary based on board fabrication site.

# EXAMPLE STENCIL DESIGN

DBV0006A

SOT-23 - 1.45 mm max height

SMALL OUTLINE TRANSISTOR



SOLDER PASTE EXAMPLE  
BASED ON 0.125 mm THICK STENCIL  
SCALE:15X

4214840/G 08/2024

NOTES: (continued)

8. Laser cutting apertures with trapezoidal walls and rounded corners may offer better paste release. IPC-7525 may have alternate design recommendations.
9. Board assembly site may have different recommendations for stencil design.

## IMPORTANT NOTICE AND DISCLAIMER

TI PROVIDES TECHNICAL AND RELIABILITY DATA (INCLUDING DATA SHEETS), DESIGN RESOURCES (INCLUDING REFERENCE DESIGNS), APPLICATION OR OTHER DESIGN ADVICE, WEB TOOLS, SAFETY INFORMATION, AND OTHER RESOURCES "AS IS" AND WITH ALL FAULTS, AND DISCLAIMS ALL WARRANTIES, EXPRESS AND IMPLIED, INCLUDING WITHOUT LIMITATION ANY IMPLIED WARRANTIES OF MERCHANTABILITY, FITNESS FOR A PARTICULAR PURPOSE OR NON-INFRINGEMENT OF THIRD PARTY INTELLECTUAL PROPERTY RIGHTS.

These resources are intended for skilled developers designing with TI products. You are solely responsible for (1) selecting the appropriate TI products for your application, (2) designing, validating and testing your application, and (3) ensuring your application meets applicable standards, and any other safety, security, regulatory or other requirements.

These resources are subject to change without notice. TI grants you permission to use these resources only for development of an application that uses the TI products described in the resource. Other reproduction and display of these resources is prohibited. No license is granted to any other TI intellectual property right or to any third party intellectual property right. TI disclaims responsibility for, and you will fully indemnify TI and its representatives against, any claims, damages, costs, losses, and liabilities arising out of your use of these resources.

TI's products are provided subject to [TI's Terms of Sale](#) or other applicable terms available either on [ti.com](https://www.ti.com) or provided in conjunction with such TI products. TI's provision of these resources does not expand or otherwise alter TI's applicable warranties or warranty disclaimers for TI products.

TI objects to and rejects any additional or different terms you may have proposed.

Mailing Address: Texas Instruments, Post Office Box 655303, Dallas, Texas 75265  
Copyright © 2024, Texas Instruments Incorporated