

## ***DLP™ System Optics***

### **ABSTRACT**

This application note describes typical architectures for optical systems employing a single DMD device for projection applications, primarily for small portable projectors. Pros and cons of architectures are discussed in general terms. Front- and rear screen applications are discussed briefly. Techniques and trades for maximizing critical system performance parameters, defined by the application, are discussed. Unique considerations for DMD devices in optical systems are addressed. A general discussion of image quality and specific design metrics for acceptable performance is included.

Note the majority of this document describes the use of the DMD in a projection optical system, and the DMD is designed with this application in mind. However, there are many other ways to use the DMD to manage and steer light energy. This document addresses some of the non-projection applications briefly, but cannot anticipate all uses.

### **Contents**

1	Overview of DMD Use in Projection Optical Systems .....	2
2	Projection Optical System Architectures .....	2
2.1	Telecentric Architectures .....	3
2.2	Nontelecentric Architectures .....	5
3	Projection Optical System Design Considerations .....	8
3.1	Illumination-System Components and Design Parameters .....	8
3.2	Projection-System Components and Design Parameters .....	13
4	System Performance Tuning Tips and Techniques .....	15
4.1	Contrast Ratio .....	15
4.2	Lumens .....	19
4.3	Optimizing Optical Costs .....	19
5	Alternate Light Sources and Systems .....	21
5.1	LED Sources .....	21
5.2	Laser Sources .....	24
5.3	Non-Imaging or Non-Projection Applications .....	25

### **List of Figures**

1	Simplified Optical Function of a 12-Degree-Mirror-Tilt Device .....	2
2	Generic Telecentric Optical System Components Using a TIR Prism .....	3
3	Telecentric TIR Prism Design Layout for Minimum Package Height Due to Projection-Lens Offset .....	4
4	Nontelecentric Optical-System Components .....	6
5	Effect of Projection Offset on Illumination Angle, Nontelecentric Design, Side View .....	7
6	Nontelecentric Optical Layout for Flat Projector Using Reflective and Refractive Illumination Elements (Isometric View) .....	7
7	Spatial Irradiance Distribution of a Small-Arc Lamp at Focus of Elliptical Reflector Before Integration (left, at rod input) and After Integration (right, at rod output) .....	12
8	Frustrated TIR in TIR Prism Air Gap Should be Biased Toward Illumination Path .....	13
9	Scattering Incident-Beam Geometry .....	16
10	Scattered Light Into Projection Pupil for Off-State Mirror, 10-Degree Device .....	16
11	Contrast and Lumens as a Function of Illumination Angle for F/3 Telecentric System .....	17
12	Keystone Distortion for 0.9 XGA by Throw Ratio and Offset .....	20

## 1 Overview of DMD Use in Projection Optical Systems

The DMD device is the heart of DLPTM projection systems. The device is a bistable spatial light modulator, consisting of an array of movable micromirrors functionally mounted over a CMOS memory cell. Each mirror is independently controlled by loading data into the memory cell below the mirror to steer reflected light, spatially mapping a pixel of video data to a pixel on a display. The data electrostatically controls the mirror's tilt angle in a binary fashion, where the mirror states are either +X degrees (on) or -X degrees (off). For current devices, X is typically 12 degrees (nominal). Light reflected by the on mirrors then is passed through a projection lens and onto a screen. Light is reflected off to create a dark field, and defines the black-level floor for the image. Images are created by gray-scale modulation between on and off levels at a rate fast enough to be integrated by the observer.

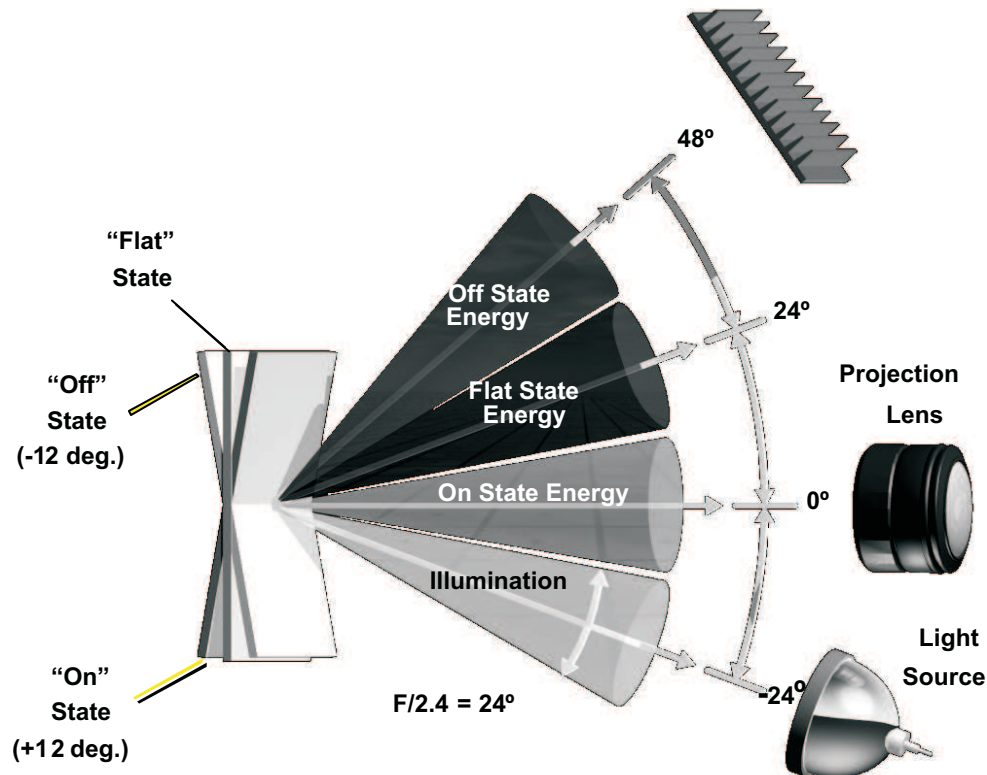

Figure 1. Simplified Optical Function of a 12-Degree-Mirror-Tilt Device

Flat state (zero) occurs when the mirrors are not energized. This is not an active state of the DMD mirrors (not tristable). The resting position of the mirrors nominally is zero degrees, but the mirrors are not controlled or actuated to this position and may vary from it slightly. Flat-state mirrors exist only when the device is turned off, or parked, and no image is being formed. This application report deals only with image effects and interactions between the device and the optical system. Therefore, it is more useful to think of flat state as the integrated energy falling in the area between on- and off-state pupils during transitions of the active mirror states, plus any fixed flat-surface contributions from the device package such as window reflectance, border metal, window-aperture reflectance, lenses or prisms, etc.

## 2 Projection Optical System Architectures

Optical systems for single-panel projection applications can be grouped into two main architectures by describing the conditions at the device. Each type has unique advantages or disadvantages that determine suitability for a given application, depending on the most critical performance parameters for that application. Pros and cons of architectures, along with distinguishing performance characteristics for certain applications, are discussed in general terms.

Because DMD devices are reflective, the illumination and projection paths to the device share the same space in front of the device. The architectures described below are typical ways to separate these paths in that space. Since the mirror hinges are along the diagonal of the mirror, the mirrors rotate about an axis

that is oriented 45 degrees to the array dimensions, and steer light in a plane compounded by this axis of rotation. Therefore, for any given location of a projection pupil relative to the device, there exists only one axis for the incident illumination path to the on-state mirrors, as determined by Snell's Law of reflection. This is the basis for many possible embodiments in detail, all of which must consider the axis of rotation of the mirrors for proper performance.

In general, the device tilt angle sets the maximum useful numerical aperture of the optical system at the device. This prevents overlap of the on- and flat-state pupils for contrast control. This rule of thumb can be "stretched", depending on performance tradeoffs allowed, but it is a good place to start. How to stretch this rule will be discussed in terms of performance parameters later in this application report.

**2.1 Telecentric Architectures**

Telecentric systems are defined by locating the exit pupil of the illumination system (entrance pupil of the projection lens) at or near infinity from the device surface. The chief rays of every bundle incident on every mirror then are essentially parallel to each other. For the illumination system, this provides uniform angles of incidence across the entire field, creating uniform black levels for the dark field. Typically, the illumination axis is separated from the projection axis by an angle just larger than twice the device tilt angle. The projection axis then is typically perpendicular to the device. If a prism is used to separate the paths (see Figure 2) the telecentric condition also produces uniform distribution of angles of incidence across the antireflection (AR) coated surfaces to avoid spatial nonuniformities in display brightness due to coating-performance variation with angle of incidence.

In the example of the total-internal-reflectance (TIR) prism embodiment, the illumination is separated from the projection path by choosing the angle of the TIR-prism face to be at the critical angle for the illumination path. The uniform angles of incidence and reflection prevent critical angle failure (TIR failure) in the projection or illumination paths through the prism.

One common embodiment of the TIR design is the so-called "Reverse TIR" or RTIR design. This is based on US patent 5309188, which employs a right-angle prism as the TIR prism. The TIR path occurs in the projection path, not the illumination path, which gives it the name "Reverse TIR." There are several advantages to this architecture, as well as few disadvantages. Contact TI for additional information on the relative merits of this design.

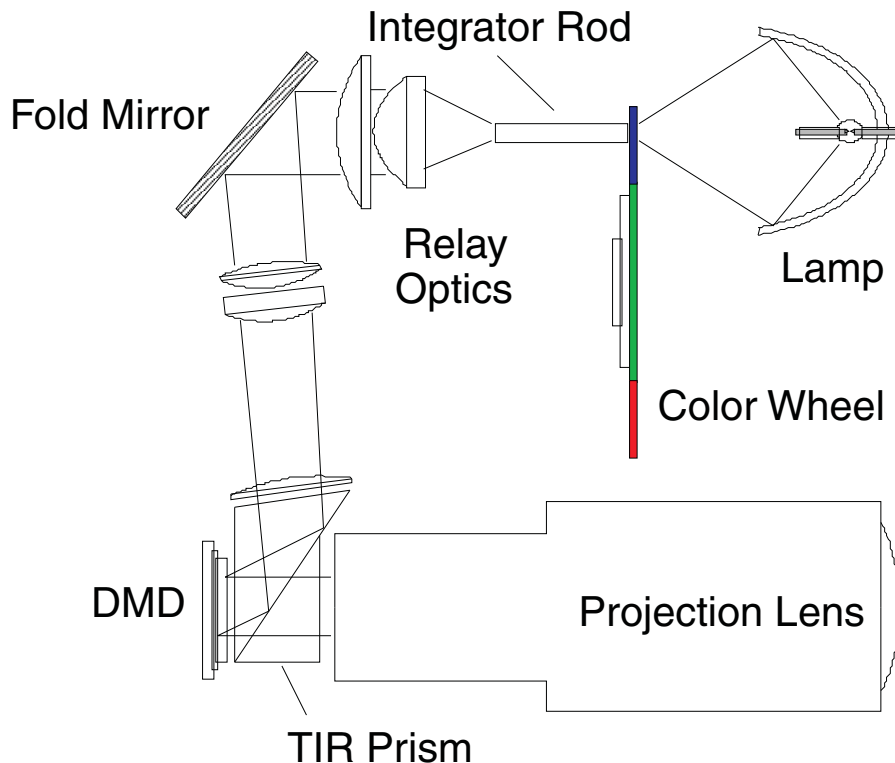
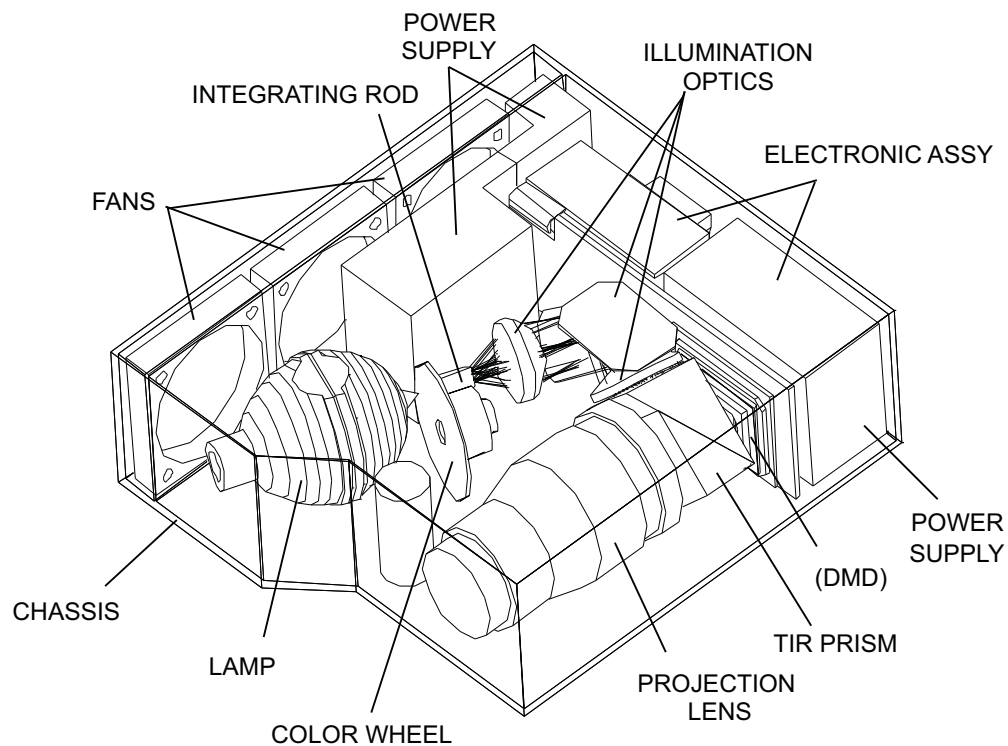

**Figure 2. Generic Telecentric Optical System Components Using a TIR Prism**

### 2.1.1 Advantages of Telecentric Architecture

Some inherent advantages/features of telecentric architecture are:

- Uniform black level due to uniform illumination angles. However, absolute black level is typically higher (worse) than nontelecentric architectures. This is due to the proximity of flat optical surfaces near the mirror device and the lower overall illumination angles.
- Separation of illumination and projection in glass rather than air space for shorter overall path length.
- Shorter back working distance for projection lens due to path in glass rather than air.
- Projection offset for keystone correction can be optimized for application to minimize field of projection lens, if the application allows.
- Variable projection offset for stacking applications, fixed-install flexibility, etc. can be achieved with prism design.
- Zero offset and minimal lens size can be achieved for rear-screen applications with prism design. Rear screens cannot accept high angles of incidence caused by offset due to Fresnel-lens screen limitations.
- Pupil location at/near infinity means no magnification changes with focus.
- Less distortion of illumination light at device (image of integrating rod) due to lower illumination angles produces less overfill losses, and higher efficiencies. However, some or all of this can be negated by prism coating efficiency losses due to high angles of incidence in the TIR air gap.
- The system can be packaged such that projection-lens offset displacement will not add to package height (see [Figure 3](#)). In this case, lens offset is vertical toward the long dimension of the prism, and does not add height to the package. Also, note that offset direction is away from flat- and off-state light paths in this configuration, minimizing the chance for stray light to enter the lens aperture and diminish contrast.
- Projection and illumination paths (for prism design) can be designed independently, allowing multiple optical sources and interchangeable lenses. This can speed time to market by having parallel development of illumination and projection optics.



**Figure 3. Telecentric TIR Prism Design Layout for Minimum Package Height Due to Projection-Lens Offset**

## 2.1.2 Disadvantages of Telecentric Architecture

Telecentric architectures have some disadvantages/challenges relative to others:

- Prism-based systems have additional costs, size, and weight of the prism. The TIR air gap has high angles of incidence, causing some polarization effects and greatly increasing the difficulty of achieving good AR coating designs. TI has reference design coatings available to minimize development efforts for these coatings.
- TIR air-gap coatings have relatively high losses, 2% to 3% per surface. These losses tend to offset the gains from reduced distortion overfill losses. However, as the f/No. decreases, these losses tend to decrease as well (coatings become more efficient).
- TIR prism surfaces also can produce surface reflections that enter the projection pupil, even though these surfaces are flat. This is because the intersection of the illumination bundle with these surfaces is displaced from the projection path, creating reflected flat-state light that is displaced from the flat-state pupil location defined by the illumination optics. This light may go to the screen if it can enter the projection lens aperture and pass through the pupil, and it is not controlled by the device state. This also is true for the DMD device window-surface reflections, regardless of architecture. All flat surfaces near the device must have very effective AR coatings to minimize this effect, and their reflections should be thoroughly traced/ modeled for possible contrast degradation. The shorter back working distances of telecentric projection lenses, while a benefit to size of the optics, is a detriment to contrast because of the lack of sufficient space to physically separate the on bundle from flat and off bundles.
- One of the strongest factors affecting system contrast is illumination angle to the device. In general, the higher the angle, the higher the contrast (more detail in [Section 4.1.1](#)). Telecentric designs have lower angles of illumination than nontelecentric designs due to lack of additional offset angle. This can reduce inherent contrast compared to nontelecentric, although it inherently is more uniform. Increasing illumination angle alone increases contrast, but also offsets the pupil in the projection lens and introduces vignetting if the numerical aperture of the projection lens is not increased accordingly. However, if the projection lens numerical aperture is increased to avoid vignetting, it can collect more flat-state and stray light from around the device and pass it to the screen, thus potentially defeating the initial intent of improving contrast. It is a tradeoff that is dependent on system requirements.
- As projection offset is added for keystone correction, the elements in the rear of the projection lens prior to the stop increase in diameter proportionally with the increase in field, because the ray bundles exit the device perpendicular to it. However, selecting only the amount of offset necessary for the application can minimize this. This is not an option for nontelecentric designs.

## 2.2 Nontelecentric Architectures

Nontelecentric architectures differ from telecentric in that the exit pupil of the illumination path is located a short, finite distance from the device, and the entrance pupil of the projection lens must be coincident with it (see [Figure 4](#)). Since some degree of vertical projection offset usually is required for most front-screen applications, additional illumination angle is added to offset the pupil in the vertical axis for the projection lens. This adds additional angle of incidence to the device, increasing inherent contrast, while providing more angular separation of the illumination path from the projection path. This additional angle makes it difficult to use a TIR-type prism for separating the paths, but a field lens (or lenses) can be used instead. Typically, the separation is in air space for minimal cost (fewest optical elements, smallest size elements). However, a field lens in this space reduces path lengths and allows more compact use of the space in front of the DMD.

Since the bundles are converging to the pupil, the angle of incidence of the chief ray for each mirror on the device varies with position in the array. Although this can produce nonuniformity of the dark field (black level), the higher average illumination angles due to the additional offset angle tends to increase the contrast (reduces black level). Also, this convergence to the projection lens minimizes the diameter of the projection lenses on the DMD side of the stop, further enhancing physical separation of the two paths.

Some designs use a field lens (or lenses) instead of a prism directly in front of the device to perform the angle separation. The field lens must be on axis with the remainder of the projection lenses, but is shared by the illumination path. This presents some challenges in illumination design since these field lenses also are part of the illumination path, but are off-axis to the DMD and tilted to the illumination path. By designing the illumination pupil near the stop of the projection lens and folding the illumination path there, a very compact system can be designed if attention is paid to the unique challenges this design presents.

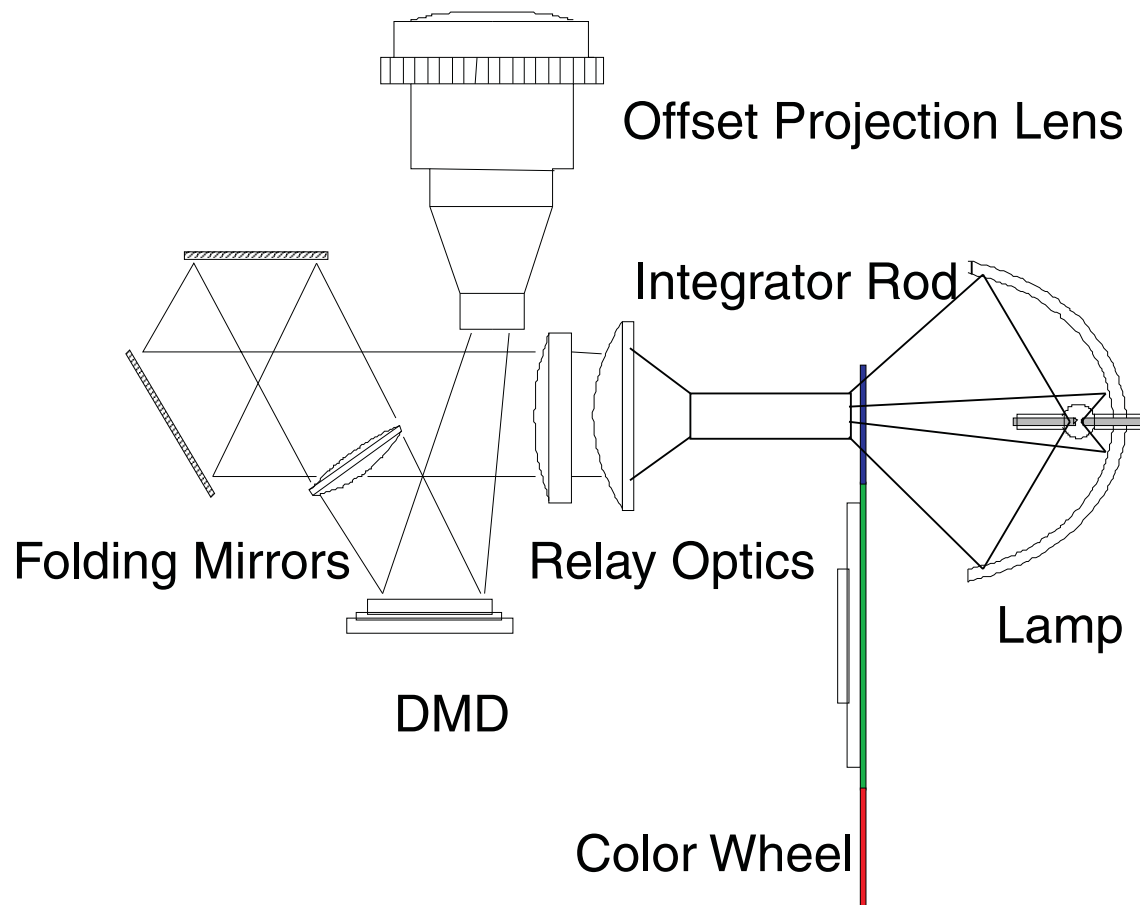
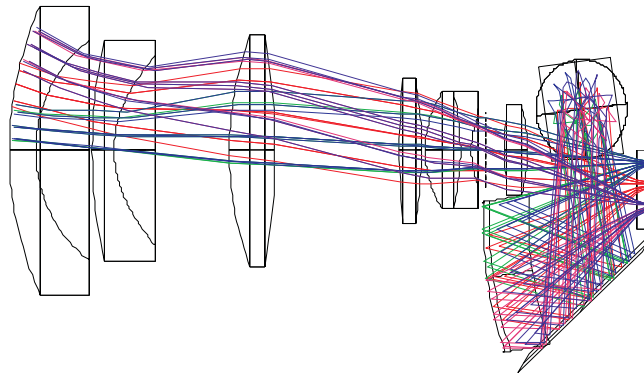

**Figure 4. Nontelecentric Optical-System Components**

### 2.2.1 Advantages of Nontelecentric Architectures

Some inherent advantages/features of nontelecentric architecture are:

- Typically the fewest number and size of optical elements for lowest cost and fewer optical element losses (higher efficiency), especially when optical offset is required for the application. Even more compact use of space in front of the DMD if a field-lens design is used.
- Offset angle increases illumination angles to higher overall angles of incidence on the device, (see [Figure 5](#)). This typically results in the highest overall contrast. The reasons for this effect are discussed in [Section 4.1.1](#).
- Inherent keystone correction of the image by placing the DMD device below the optical axis of the projection lens. This generally is required to achieve enough angular separation of the illumination and projection optics for packaging.
- Smaller optical elements in the rear of the projection lens (before stop) due to finite pupil location. However, these designs typically have more elements in front of the stop due to limited space behind the stop, so front elements can grow quite large for fast throw ratios and may negate overall savings.



**Figure 5. Effect of Projection Offset on Illumination Angle, Nontelecentric Design, Side View**

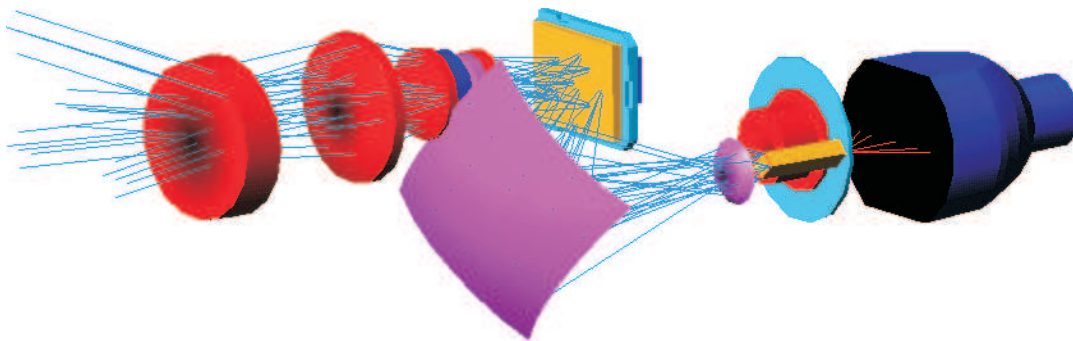

**Figure 6. Nontelecentric Optical Layout for Flat Projector Using Reflective and Refractive Illumination Elements (Isometric View)**

### 2.2.2 Disadvantages of Nontelecentric Architectures

Nontelecentric architectures have some disadvantages/challenges relative to others:

- Nonuniform angles of incidence of the illumination at the device produce variation in the absolute black level, even though the absolute level generally is much lower overall than other architectures.
- Vertical offset requirements increase as  $f/\text{No.}$  decreases (numerical aperture increases) in order to physically separate illumination and projection optics. This is because the bundles get larger with smaller  $f/\text{No.}$ . The amount of vertical offset generally determines the package height of the projector, since it must be located opposite the illumination input. In contrast to telecentric prism designs, the projection lens cannot be offset toward the illumination to minimize package height (see Figure 6). However, this characteristic can be taken advantage of in a “tower” style layout, where the projector is arranged vertically.
- Projection lens elements on the screen side of the stop tend to become larger than telecentric elements because more of them are located on one side of the stop. Near the front (screen side) of the lens, much of the glass is not used, but truncating the glass to save weight generally is more expensive than practical, especially since it does not reduce packaging height.
- The higher illumination angles distort the image of the integrator rod more severely at the device, which creates more overfill losses. This can be as much as 10% less efficient than a telecentric design, depending on uniformity requirements and the number and type of illumination elements used. Likewise, these higher angles tend to distort the exit pupil of the illumination system, making it difficult to define for the projection lens design and producing further losses.
- Matching pupils at a finite distance from the device requires knowledge of the illumination system in order to design a proper projection lens, and vice-versa. This interdependence can hamper parallel-path development and increase time to market, especially if separate suppliers are involved.
- The high offset angle produces projection angles that generally exceed current screen technology for rear-projection applications. Reducing offset is not an option, nor is variable offset, for nontelecentric

designs.

- Higher illumination angles require more clearance for the window aperture opening so that rays can enter the active area without vignetting or shadowing the active array. This requires more silicon border, or light shield, area around the active array to push bond wires and other structural artifacts out of view under the aperture. This reduces the number of DMD die that can be produced per wafer, impacting the DMD cost.
- More off-state light is trapped in the device by the device window aperture, which can produce undesirable thermal effects and border artifacts.
- Magnification changes slightly with focus of the projection lens.
- Higher offset requirements result in larger field size requirements for the projection lens. Field size is by far the single most influential design parameter for lens cost and performance. Offset cannot be optimized to minimize field size as for a telecentric prism-based design.
- It is very difficult and expensive to design a constant  $f/\#$  zoom lens for nontelecentric architectures due to change in stop position. Fixed-stop-position zoom lenses are complex and very difficult to make. Large zoom ratios tend to produce large brightness variation, accordingly. Movement of the rear group in a zoom lens also is hindered by potential interference with illumination elements, which can make large zoom ratios very difficult.
- Proximity of stop to rear aperture in a projection lens makes it difficult to manage stray light entering the projection lens. Also, for this reason, no illumination surfaces should be closer to the device than the rear of the projection lens, as they tend to become sources of stray light entering the projection lens.
- Field-lens surface reflections from the illumination path are not controllable by the device state. These reflections can enter the projection lens pupil and deteriorate contrast. Careful modeling of surface reflections with commercially available optical design software is imperative.
- It is very difficult to design lens-shift into a non-telecentric design. The numerical aperture of the projection lens has to be oversized by the amount of lens shift desired. This creates low  $f/\#$  projection optics and flat state light overlap management issues. Also, it increases the size of the lenses, causing a need for more physical separation (offset) of the illumination and projection ray bundles.

### 3 Projection Optical System Design Considerations

Regardless of the architecture, system design consists of an illumination system and a projection system. In some cases, these systems can be treated independently. In others, particularly those designs having field lenses that are in the path of both the illumination and the projection systems, there is obvious interaction that must be accounted for. The following paragraphs address the design considerations and the components of each system.

#### 3.1 Illumination-System Components and Design Parameters

The simple function of the illumination system is to collect as much useable light as possible from a light source and put it on the device active area (mirror array). The components typically used to do this are: lamp, reflector, color wheel, integrator, relay and folding optics (including field lenses, if any), and, possibly, a TIR prism.

##### 3.1.1 Lamp

Lamp selection depends on several factors:

- Projector size/weight/noise goals. Most lamps are rather inefficient at converting electrical energy into visible light. This means there will be a thermal load on the projector from the lamp. In most cases, this load is the highest load in the system. The amount of power (heat) that can be dissipated by the projector is determined by the number and size of the fans used to cool it, given projector size, weight, and noise requirements. The most efficient lamp, in terms of lumens per watt output collected into the available etendue of the device, is the parameter to optimize.
- Life. Lamp life requirements vary by application. Consumer applications require very long lamp life to overcome consumer resistance to replacing a high-cost lamp. Lamp life of 5000 to 10000 hours, or more, in the product is required for these applications. Portable projectors, however, typically see relatively infrequent usage. Lamp life of 2000 hours in these products can exceed the products' useful lifetime, given the duty cycle. One must be careful to understand what a lamp manufacturer may mean



by lamp life, versus what a product requirement for lamp life means. Typically, product lamp life means no less than 50% of initial product brightness output after the specified lifetime under certain duty cycle requirements with few, if any failures. Manufacturers typically specify catalog lamp life in terms of 50% of a sample lot still running after a specified period of time, usually under ideal thermal conditions. These are very different requirements, and both parties must understand what is meant or needed.

- Spectral content. The output spectrum of the lamp must be balanced into useable color space in the projector by the color-wheel. The efficiency of this conversion can vary greatly from lamp to lamp. TI has a color-wheel design/modeling tool that can compare the relative efficiencies of lamps after color-wheel conversion. The results often are not obvious. As a rule of thumb, the closer the CCT of the lamp is to the desired whitepoint of the projector, the more efficient the lamp/color-wheel combination will be.
- Commutation and arc stability. Whether the lamp is ac or dc, and whether it has some means of preventing arc jump or arc flicker, can be important factors in the application.
- Efficacy at small etendue. Like most projection display technologies, device panel size (area) combined with the maximum allowable numerical aperture (solid angle) determines the system etendue. This typically requires small plasma-arc sources, volumetrically constrained under high pressure. Matching the lamp etendue to the system etendue is the goal for maximum efficiency.
- Most lamps have requirements for operating position relative to gravity. Make sure the projector layout does not violate lamp-orientation requirements in all end-use applications.

### 3.1.2 Reflector

The lamp reflector collects the light from the lamp and directs it into the illumination optics. Characteristics of the reflector are:

- Cold-mirror dichroic coating to minimize downstream UV and IR loads on optical components and the DMD.
- Elliptical (or similar) shape. Most single-panel DLP systems utilize an elliptical reflector to focus the light into a small spot on the color wheel. Systems that use parabolic shapes must add condenser optics between the lamp and color wheel to focus the lamp. As the lamp arcs approach a point source, the pure ellipse becomes more difficult to improve upon. However, lamp bulb walls may have thickness and shape variations that can cause distortions that can be corrected by higher order reflector curves.
- It is the function of the reflector to minimize the spot size at the wheel such that the transition spokes between colors of the wheel can traverse the extent of the spot in the shortest amount of time possible. Although the mixed-color light in the spoke transitions eventually is combined into useable light, the angle subtended by the spoke transitions becomes a larger percentage of the total 360 degrees as the radius of the wheel is reduced. This leaves less time for each of the pure primary colors, eventually approaching a limit determined by the amount of time required to fit all the bits required into each particular color. This time also is a function of the lamp spectral balance, so it is a system-level problem to optimize. The TI color-wheel modeling tool should be applied to this problem.
- The reflector must contain bulb rupture. Also, some means of protecting the color wheel from damage due to bulb rupture may be a part of the reflector assembly, such as a cover glass at the reflector exit. A cover glass is also a good place for UV and IR filters, if needed. The reflector volume usually determines the thermal environment for the lamp, and, therefore, has a great impact on lamp life in the projector. Some provisions for cooling the lamp burner may be required as the reflector volume is reduced for small products.
- Reflector surface quality becomes increasingly important as reflector surface area is reduced for small reflectors. Surface imperfections usually are a function of the manufacturing process, and become a relatively larger percentage of the total area as the reflector area is reduced for small products.
- Avoid placing optical elements, such as lenses or windows, between the reflector face and the reflector focus. If necessary, place them as close to the reflector face or the focus as possible, and/or tilt them so that the reflected energy does not go back along a path that will focus on the lamp burner electrode tips or wires. Elements near the midway point between the face and the focus reflect lamp energy back that can focus on or near the tip of the lamp burner, unless tilted. This can cause accelerated lamp failures due to electrode oxidization or thermal gradients. For example, this can occur if a condenser lens is added to slightly change the numerical aperture of an off-the-shelf reflector rather than designing and tooling a custom reflector.
- Be aware that the color wheel reflects a load back into the lamp/reflector assembly equal to the complement of the wheel efficiency, which can be as much as 2/3 of the lamp output. This definitely

affects the thermal environment in the lamp/reflector assembly, and must be accounted for in the design.

- The reflector curve has a large impact on the shape of the far-field angular distribution of the lamp/reflector output. This angular-weighted distribution affects the design of the color wheel filters, and should be accounted for in pupil-weighted MTF calculations for projection-lens performance.

### 3.1.3 Color Wheel

The design of a color wheel is covered in a separate application note. Optically, it is a series of dichroic filters arranged in segments around the diameter of the wheel, which pass red, blue, green, yellow, magenta, cyan, or white light as the DMD device sequence requires. Some optical considerations are:

- Dichroic filter performance as a function of angle of incidence. The smaller the spot on the color wheel, the better for timing purposes. However, usually this is achieved by increasing the speed, or numerical aperture, of the lamp reflector. This creates increasingly higher angles of incidence on the filters, changing performance and softening cutoff slopes in the process. The cost of improving cutoff performance with more coating layers should be weighed against the spot-size savings when considering going faster than about  $f/1$  at the color wheel.
- Location of the wheel. In all the system configurations shown, the color wheel is placed prior to the integration rod, immediately after the lamp. In field-sequential applications using a color wheel, it is more efficient to transition the color-wheel spokes through the lamp spot rather than through the integrated output of the integrator rod. This is because the lamp spot usually is much more spatially compact than the output of the rod; otherwise, there would not be a need for the rod. Also, the spoke light-recapture algorithm, if used, works better if the spoke transition is spatially mixed before reaching the device.
- The wheel should be located as close as is practical to the integrator entrance face, considering wheel runout, vibration/shock loads, and positional tolerances. Typically, 1 mm spacing is adequate. This small space has little effect on spot size at the wheel. Typically, the focus beam waist of the lamp in this Z-axis is much longer than this space.
- Placing the wheel prior to the integration rod also relieves significant thermal load on the rod. One thermal benefit of the wheel is that the heat from the focused spot is distributed in an annular ring of much larger surface area due to the rotation of the wheel, and there is some forced-convection cooling due to the rotation as well. However, this benefit shrinks as the wheel diameter decreases, so thermal loading of the color-wheel motor should be monitored in system design.

### 3.1.4 Integrator

The integrator function spatially redistributes the image of the arc from a highly peaked distribution to a more uniform, flat-topped distribution, resulting in relatively flat spatial distribution of light on the screen (see [Figure 7](#)). As lamps become more etendue matched to the devices, they become more spatially nonuniform at the focus of the reflector, so some kind of integration technique always is used on DLP products today. Although frequently used in LCD products, lens-array type integrators (fly-eye) are not a good choice for DLP projectors except in cases where absolute minimal path length is required. A rod integrator, solid or hollow, is the best choice for reasons described in the following paragraphs. Types and characteristics of various integration techniques are:

- Lens arrays. Lens arrays typically are two molded lens-array plates spaced a certain distance apart. Typically, they are used with a parabolic reflector in near-collimated space to facilitate design. This is convenient for three-panel LCD or DLP products that do not require a focus through a sequential color wheel, but not for single-panel DLP products. Typically, lens arrays are less efficient than a rod-type integrator for several reasons, most having to do with manufacturing techniques. Most are molded glass, requiring small drafts between lens elements in order to release from the mold. This area represents lost light. This loss is repeated for every lens element on every plate. Then, the array on the first plate must accurately align with the array on the second plate; any misalignment causes further losses. Then, each image formed by the lens pair from each plate must accurately image to the device array. It is not possible to align each image formed by each pair independently because they are molded together into plates, the image must be large enough that any tolerances in position of the device array relative to the lens array (and vice-versa) will be accounted for. All of these tolerance buildups result in larger losses relative to a single rod image. And finally, the quality of collimation of the incoming light beam determines the amount of crosstalk between lens pairs. When a skew ray from one lens enters the adjacent lens (crosstalk) instead of the one directly paired with it, this ray is lost to

overflow.

- Solid-glass-rod integrators. These are commonly used, but increasingly are being replaced by hollow mirror-integrator tunnels. They both work on the same principle of creating reflections inside the rod to spatially randomize the input to a more uniform output, without changing the numerical aperture. The solid glass rod does this by total internal reflection off the glass/air sides. The number of reflections inside the rod is a function of the index of the glass, the numerical aperture of the input, and the cross section and length of the rod. It is somewhat challenging to mount an unclad glass rod in a system, because every point of contact with the wall creates TIR failure where light exits the rod, causing throughput loss as well as a concentrated thermal load at the point of contact. Also, the rod entrance and exit faces should be AR coated without spilling over to the sides, which can be a relatively expensive process. Since the output face also is in focus on the device (and therefore screen), any imperfection or dust particle that settles on this face will be imaged to the screen and appear as image defects. Also, the number of reflections per unit length of rod is lower in glass than in air due to the index of the glass, requiring a longer length of rod for the same amount of integration. Finally, safety bevels on the faces usually are required to avoid chipping, but increase overflow losses in proportion to their size.
- Theoretically, TIR is more efficient than a mirror reflection, so, for relatively long rod lengths and/or high-powered systems, glass (or fused silica or quartz) is still the preferred choice due to efficiency and thermal effects. Exit-face dust protection can be provided by abutting or attaching a thick plate to the exit face, thus displacing the dust to an out-of-focus position, or by sealing the space between the exit-face and the first element downstream.
- Hollow mirrored tunnels increasingly are used in smaller systems for several reasons. First, they produce more integration per unit length because they are working in air (index = 1) instead of glass. Hollow tunnels can be shorter than solid rods for the same application. Second, there is no output face to collect dust or imperfections to image to the screen. Third, there are no faces to AR coat, which makes the overall efficiency about the same for short lengths. Fourth, they are much simpler to mount because there are no TIR failure points. The only drawback is the tendency to operate at higher temperatures due to the absorption losses in the mirror coatings, which can weaken adhesives if used to assemble the mirror sections, or create localized heating issues. Also, sizing adjustments are easier and faster to implement with a tunnel.
- Design considerations. Typically, TI recommends an integrator length that will produce an approximately 4 x 5 array of arc images for acceptable uniformity, depending on application. Some applications require up to 8 x 10 array images or more, especially if there is arc flicker or arc jump to mitigate. It is recommended that uniformity be modeled in optical design software to determine the optimum length based on the arc profile, far-field distribution, lamp-focus position, and length of the integrator. As the rod length is decreased, the sensitivity of uniformity to lamp-focus tolerances becomes more critical.
- An image is created in the array each time the marginal ray crosses the optical axis. The array can be observed in any pupil of the illumination relay, where there are multiple images of the cross section of the rod in a rectangular array, each image containing an image of the arc as viewed by the angles subtended to the arc from that image. The outer array images represent the highest angles of light from the lamp reflector; the interior array images are the shallowest angles. In the center, typically there is a dark spot representing the innermost angles shadowed by the lamp electrodes.
- Cross-section sizing. The size of the cross section is determined by optical performance of the illumination relay, the assembly tolerances, and the size and tolerance of the device. At a minimum, the size should prevent any chromatic artifacts or vignetting in the image at the device (screen). Tolerance stackups in the size, position, and magnification of the image of the integrator through the optical system, and the mechanical tolerances from the integrator mount to the device die in the DMD package itself, must all be accounted for. This can be done by oversizing the integrator cross section to always allow the device to be in the image of the integrator, but it results in large overflow lumen loss (efficiency) because the area outside the device contains light that otherwise could be useable. The loss is even more significant for highly uniform profiles created by longer integrator lengths, because the outer areas are nearly as bright as the central areas. A better, more common approach is to size the cross section for minimum overflow and adjust the position of the image to the device at some step in projector assembly. This is a relatively simple process (see [Figure 4](#)), and it eliminates many tolerance stackups to allow maximum brightness.

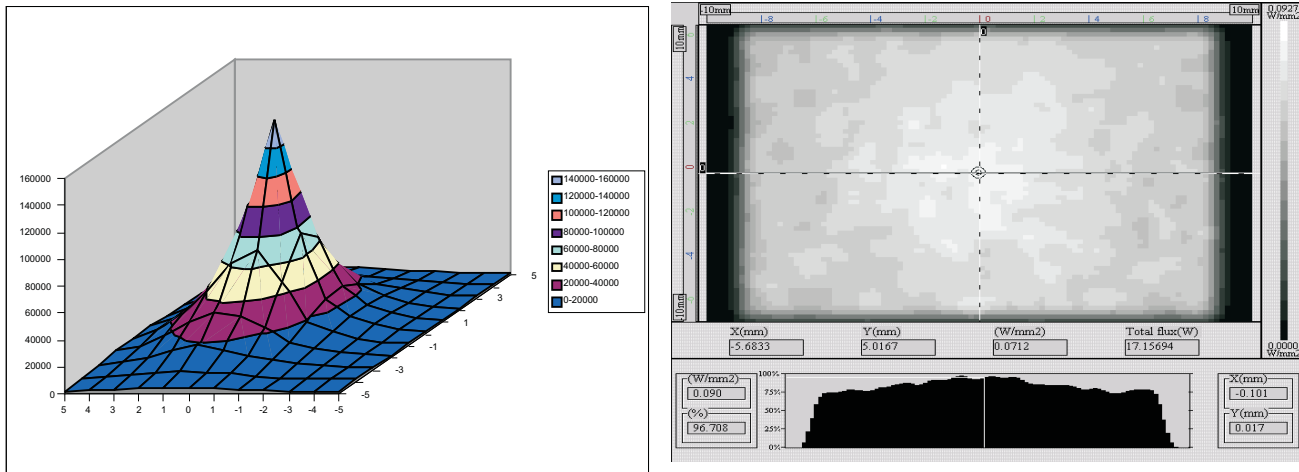

(Highly peaked Gaussian profile maps directly to screen uniformity unless redistributed by spatial integration.)

**Figure 7. Spatial Irradiance Distribution of a Small-Arc Lamp at Focus of Elliptical Reflector Before Integration (left, at rod input) and After Integration (right, at rod output)**

### 3.1.5 Relay/Folding Optics

Relay optics can be reflective, refractive, or a combination of the two. In applications using a rod or tunnel integrator (nearly all single-panel DLP applications), the relay is a classical Abbe configuration, forming an image of the rod/tunnel face at the device plane. Also, this creates a convenient field stop at the device, minimizing thermal problems and border artifacts due to illumination overfill. The function of the relay is to transfer as much of the light from the output of the integrator to the device with acceptable uniformity, and to match the numerical aperture at the integrator to the numerical aperture of the projection with appropriate magnification. Whether the relay is telecentric or not at the device, it always should be telecentric at the integrator to avoid color and spatial uniformity problems. Use of folding mirrors and the overall path length usually are determined by packaging constraints or goals, and vary from product to product. One possible benefit of curved reflective elements in the illumination relay is that these can perform the functions of both a lens and a fold mirror in one compact element. However, large off-axis angles often required for folding can have detrimental effects on uniformity, distortion, spectral transmission, polarization, and other aberrations of a curved mirror. Irradiance profile at the device always should be modeled by suitable software programs. Other considerations are:

- Illumination relays must be optimized for minimal optical blur at the outer edges of the integrator rod or tunnel field. This is contrary to a typical imaging system, where performance usually is optimized near the center of the field. Proper weighting of the field during design optimization maximizes brightness by minimizing blur at the edges of the image, which reduces the size of the integrator cross section and, thus, the amount of overfill.
- Integrator sizing also must account for Scheimpflug distortion caused by the angle of incidence of the illumination relay to the device. Decentering, tilting, aspherics, Scheimpflug correction of the exit face of the integrator, or some combination of these can be used to improve this in some cases. Minimizing this distortion is important for efficiency and thermal reasons.
- Typically, distortion overwhelms blur for nontelecentric illumination relays due to the much higher illumination angles to the device created by the additional offset angle.
- Telecentric relays have lower illumination angles, and thus lower distortion, but may require more elements to control blur better because distortion is lower.
- One benefit of field-lens architectures is that usually there are more optical elements (surfaces) in the illumination path to help optimize blur (usually a chromatic aberration). The field lens itself is decentered and tilted with respect to the illumination optical axis, which may help correct Scheimpflug distortion.
- Vignetting can be applied to reduce the diameters of the elements required because the illumination is centered on the device. Uniformity goals should not be compromised, and brightness at the ANSI measuring points for lumens should be maintained. Keep in mind, however, that ray bundles are

reversed by reflecting off the device, turning inside rays out and vice-versa. Corresponding vignetting in the projection path may be required to achieve the desired effect, or judicious placement of apertures in the illumination.

- Always include the device window and window aperture in the model or design to make sure no shadowing of the array occurs from the window aperture, and to estimate thermal load on the window aperture due to overfill.

### 3.1.6 TIR Prism

Some telecentric architectures utilize a prism containing a TIR surface to separate the illumination and the projection paths in minimal space. Some design considerations are:

- Bias the frustrated-TIR zone to the illumination side by choosing the prism angles for maximum contrast. There is an area of frustrated TIR and resonance with the AR coatings near the critical angle that prevents instant switching from TIR to refraction at the critical angle (see Figure 8). For better system contrast, it is usually better to let this failure occur in the illumination path rather than the projection path.
- The AR coatings on the air-gap surfaces have high angles of incidence and require special attention to coating design. A reference coating design is available from TI.
- Reflections of flat- and off-state light from the device should be managed and prevented from entering the projection lens. This can be done with the shape of the prism, absorptive coatings on nonoptical surfaces of the prism (beware thermal implications), apertures in the projection path, or some combination of these techniques.
- Judicious vignetting can be used to minimize the size of the prism.
- The prism air gap should be about 10 microns to prevent astigmatism in the projection path. This does not apply to RTIR designs because the air gap (if applicable) exists in the illumination path, not projection, and is of little consequence to the illumination.
- All optical surfaces should be AR coated to minimize contrast degradation and maximize throughput. Because light goes into and out of the prism twice (double-pass), and because of the difficulty of having AR coatings in the air gap, typical overall transmission for a prism is about 92% to 93%. However, this can increase as the f/No. decreases.

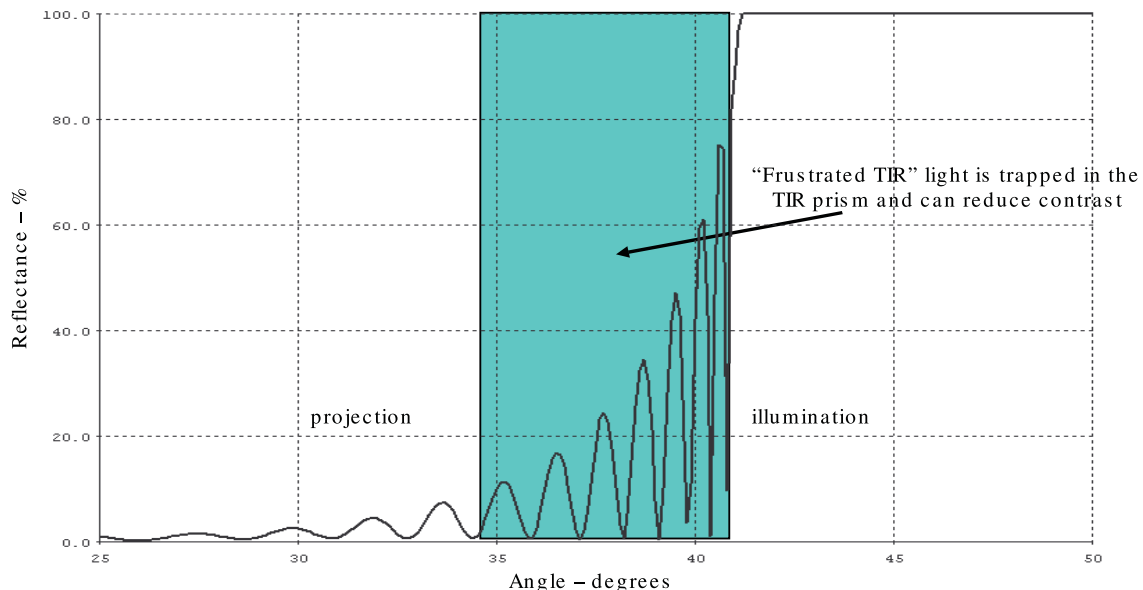

**Figure 8. Frustrated TIR in TIR Prism Air Gap Should be Biased Toward Illumination Path**

## 3.2 Projection-System Components and Design Parameters

The function of the projection system is to magnify an image of the device to a screen, while maintaining throughput and uniformity. It consists of a projection-lens assembly (fixed-focal length or zoom), possibly a

TIR or RTIR prism, and the device. If used, a TIR prism in the projection path basically is a flat glass plate and has little effect unless the air gap is large enough to introduce astigmatism. The device window also is a flat glass plate that should be included in the design model. The performance of the system can be described and measured in classical metrics for an imaging system, such as modulation transfer function (MTF), specific image aberrations, numerical aperture, etc. As for other imaging systems, the design of a projection lens is a balance of performance, cost, size, weight, volume, environmental requirements, and other system parameters. Factors influencing projection lens design are:

- Throw ratio. The ANSI definition of throw ratio is the distance to the screen image from the projector divided by the width of the image. There are many other definitions, such as those based on the image diagonal or the inverse of these relationships, so be sure there is mutual understanding when discussing throw ratio. Throw ratio is determined by the focal length of the projection lens. Typically, it is constrained by the application desired, but, in general, the longer the throw ratio the longer the focal length and the smaller the lens. For the smallest lens possible, make the throw ratio as long as possible for the application. Typical throw ratios for conference room or mobile front-projectors are in the range of 1.5:1 to 2.2:1. For rear-screen projection in a TV application, the throw required usually is limited by the screen technology or cabinet layout and usually is much less than 1.0:1 (typically, 0.55:1).
- Numerical aperture or  $f/\#$ . Typically, this is determined by the device mirror-tilt angle to prevent overlapping flat- and on-state bundles. It limits the throughput, or etendue, for the entire projection system. However, the mirrors only steer the light along one axis. In the axis orthogonal to the steering plane, there is no functional limit to numerical aperture. In practice it is difficult to create nonsymmetrical numerical apertures, but the benefit can be large.
- Focus range. This is the range of distances from the screen to the projector within which the image is expected to be in focus. Although not difficult for a fixed-focal-length lens to accommodate, it has a significant effect on the design of zoom mechanisms. Also, it is important to consider the tolerance for the location of the device plane due to variations in die height and/or package type when designing focus mechanisms, particularly zoom lenses.
- Image distortion. Typically, a design goal of  $\pm 1\%$  maximum distortion is required for acceptable performance with projectors used for graphics. This can be 2% total distortion if there are no inflections. Even higher amounts are acceptable for video or photo type applications.
- Lateral color. A single-panel DLP system is permanently converged, by definition, as opposed to a three-panel LCD system in which each panel must be made to align with the other two on the screen. Over time, a the three-panel LCD mechanism drifts out of alignment, creating secondary color artifacts around the pixels. However, lateral color aberration in a projection lens can produce pixel color artifacts that appear similar to misconvergence of three-panel systems. For most graphics applications, lateral color of less than 1 pixel from 430 to 670 nm gives acceptable performance. Experience has indicated that the MTF requirements defined below usually can be met with ease if the lateral color requirement is met.
- Field size is a very strong factor in lateral color correction. Field size. The device active-area dimensions and the amount of offset required for keystone correction determine the size of the field that the projection lens must image to the screen. In general, field size is by far the strongest factor determining the lens complexity, size, cost, and performance limits. Any relief in field size requirements usually yields big dividends. Because performance goals and panel sizes are fixed, offset is the key variable to scrutinize. For a nontelecentric system, or certain field lens systems, offset is not selectable. In those cases, offset is required to physically separate the illumination and projection optics or to control ghost surface reflection paths. However, for a telecentric system using a TIR prism, offset can be any amount desired, including zero. In section 4 of this application report, more detail is given about minimizing offset, while achieving acceptable system keystone performance.
- MTF. Graphics projection is a more demanding application than video for image quality because graphics map directly to pixels and typically consist of many lines and characters that are orthogonal to one another. MTF is the metric for describing how well a lens resolves, or focuses, an image feature. It is specified in two orthogonal directions, sagittal and tangential. Please refer to any standard optical textbook for details about MTF and how it is measured, if needed. TI recommends optimizing MTF in the design of the lens by photopically weighting the spectrum and by angular weighting of the pupil according to the lamp/reflector far-field distribution, in order to achieve the best correlation to actual projector performance. TI recommends a minimum of 40% MTF (average of sagittal and tangential) at the Nyquist (fundamental) frequency anywhere in the lens field at a single plane of best focus for the entire field. In addition, there should be no more than 20% difference between sagittal and tangential MTF at any field point (astigmatism) because there are many vertical and horizontal features in

graphics display and the operator desires all of them to be in focus at the same time. These values are actual lens-performance minimum values or, equivalently, the 3-sigma tolerance design limits. Nominal design MTF minimums are 10% to 20% higher, depending on the manufacturers' processes and design sensitivities. It is important to include the DMD device parallelism tolerance as part of the lens tolerances when optimizing the design (see [Section 4.3.2](#) for reference).

## 4 System Performance Tuning Tips and Techniques

Many system performance parameters have limits set by, or are influenced by, the DMD device itself. For example, if the device is replaced by a flat mirror in a typical high-quality optical system, the system contrast ratio would be at least an order of magnitude higher than with the device in place. Therefore, system performance parameters are very sensitive to how the design is optimized relative to interactions between the device and system optics, and can be optimized to achieve product differentiation and optimal performance for given applications.

### 4.1 Contrast Ratio

For single-panel optical systems, the DMD devices usually are the limiting contributor to the full on to full-off (FO:FO) system contrast ratio. This is the ratio of lumens projected with the device turned on (full-white screen) to the lumens projected when the device is off (full-black screen). The device alone cannot be described as having any contrast ratio, because the light exiting the device is constant, regardless of the active state of the mirrors. It is only until system pupils are defined, which constrains a solid angle of collection, that contrast can be defined because contrast can have meaning only as a system parameter. However, the device determines the limit of FO:FO system contrast ratio, so it is important to know how the device interacts with the system to affect this (and other) parameters.

ANSI checkerboard contrast is measured by projecting a checkerboard pattern of white and black squares arranged such that 50% of the area of the screen is white and 50% is black in total. In this case, light is directed through the projection lens optics; therefore, the quality of the lens design, materials, and coating processes contribute to the contrast limit.

For current production devices used in single-panel systems, the most significant factors influencing system contrast ratio are: illumination angle, mirror gap (related to mirror tilt angle), numerical aperture, and optical design/coating quality.

#### 4.1.1 Illumination Angle

Illumination angle refers to the angle of the chief ray of the bundle incident on each device mirror. For telecentric architectures, these rays essentially are the same angle across the entire array. For nontelecentric architectures, these rays vary for every mirror across the ray due to the convergence of the illumination bundle to a finite pupil.

The illumination angle interacts with device and system optical characteristics to produce contrast-limiting conditions in several ways:

- The angle determines whether the reflected flat-state light misses the projection-lens pupil, and by what margin. It also determines the location of the pupil in the off-state and the on state, in combination with the device mirror-tilt angle.
- There is a strong dependence between the angle of illumination and the amount of light scattered into a projection pupil by multiple reflections from underneath the device mirrors when they are off. This is due to shape and reflectivity of the structure and materials used for constructing the layers under the mirrors, which tend to behave specularly. As the mirrors tilt to off, they expose more of this area under the mirror to the incoming illumination light.
- Scattered light from the edges of the mirrors and mirror vias enters the projection lens pupil as a function of the illumination angle (see [Figure 9](#) and [Figure 10](#)).

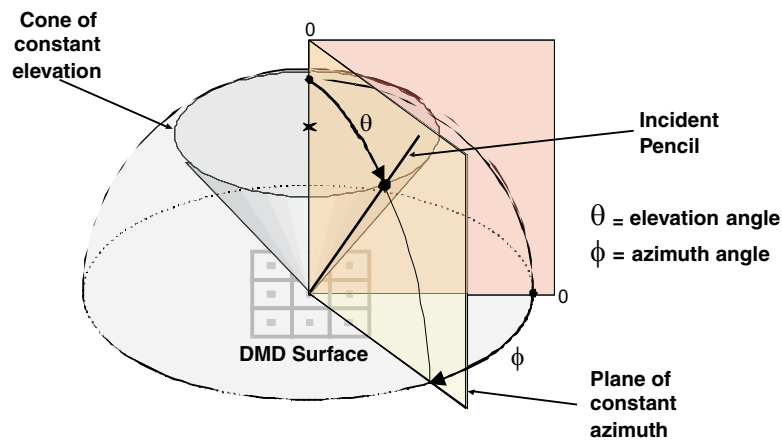

**Figure 9. Scattering Incident-Beam Geometry**

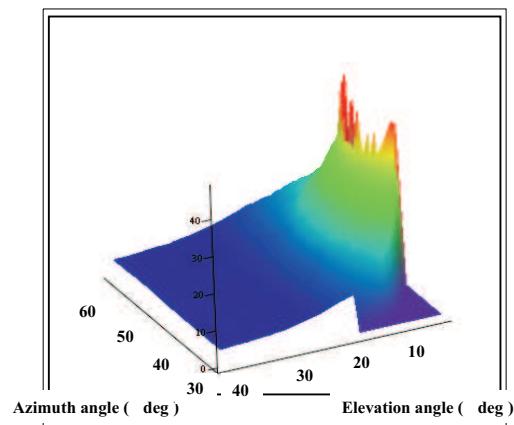

**Figure 10. Scattered Light Into Projection Pupil for Off-State Mirror, 10-Degree Device**

- Incident rays closer to the mirror-tilt angle contribute the bulk of scattered light into the collection aperture. The case of [Figure 10](#) represents a telecentric f/3 system for an older design 10 degree device with a projection axis along the 20-degree elevation angle (i.e., nominal 20-degree illumination angle). For telecentric systems, the illumination angle nominally is 2X the mirror tilt angle, and the numerical aperture typically is set by the mirror-tilt angle. So, in [Figure 10](#), the 20-degree elevation angle is along the nominal projection axis, and the projection cone (numerical aperture) is  $\pm 10$  degrees from it. This maximizes pupil fill and aligns the illumination pupil to be nominally centered in the projection pupil for maximum throughput (lumens) with good contrast. However, a large percentage of the scattered light can be avoided by shifting the illumination angle to higher angles, keeping the same numerical aperture ( $\pm 10$  degrees in this case). The high scattered-light content of the shallow angles then is avoided for much improved contrast. However, the illumination pupil now is misaligned with the projection pupil by the amount of the increase, causing lower lumens. For a typical 10-degree telecentric system and lamp-pupil profile, the tradeoff between lumens and contrast by increasing illumination angle is shown in [Figure 11](#). The device used in this example is now obsolete, but the behavior illustrated is representative of current device behavior.



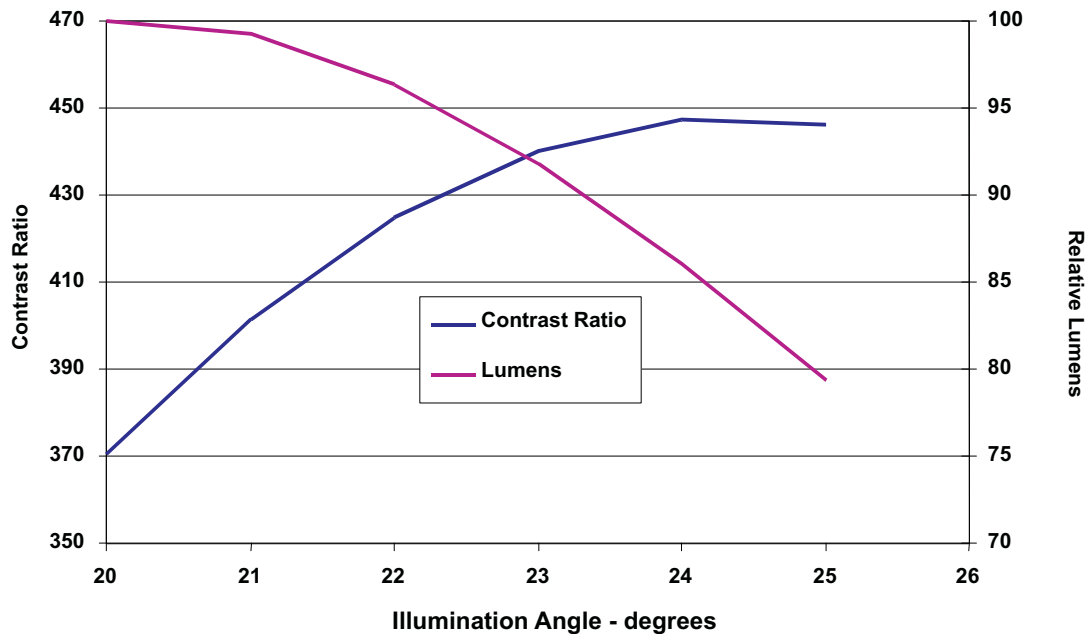

(17- $\mu\text{m}$ , 10-degree tilt, 0.8- $\mu\text{m}$  mirror-gap device)

**Figure 11. Contrast and Lumens as a Function of Illumination Angle for F/3 Telecentric System**

- For example, in [Figure 11](#), increasing the illumination angle to 22 degrees for this device in this system would improve FO:FO contrast by about 14%, while decreasing lumens about 4%, which may be a good tradeoff for certain applications requiring the best contrast performance, such as video applications in darkened rooms or rear-projection. In applications where real contrast more likely is limited by ambient room conditions, this improvement in contrast may not be as important as lumens. In fact, room-limited contrast for front projection actually will be improved by maximizing projector lumens at the expense of some actual projector contrast because the black level will be set by the room (not the projector), but the white level will be set by the projector (lumens).
- Also, [Figure 11](#) shows that increasing the illumination angle even further continues to produce contrast gains, but at the expense of lumens in a telecentric system. This is because the pupil of the illumination system increasingly is not steered back into the projection pupil by activating the device to on; it can steer only by 2X the tilt angle. One may be tempted to avoid the loss in a telecentric system by oversizing the pupil in the projection lens, but that makes the lens larger and more expensive and causes it to pick up more flat-state light, thus defeating the purpose. Another way is to decenter a smaller pupil in the projection lens, but this is very difficult and complex to implement mechanically, and does not make the lens any smaller or less expensive. If maximum contrast is required with maximum lumens, consider employing a nontelecentric architecture with offset projection. In this case, the offset angle increases the nominal illumination angle much higher (near 30 degrees or more at the center of the device), which [Figure 10](#) shows has significant impact on system contrast because a large portion of the scattered light from the device is now avoided. However, unlike telecentric systems, the projection lens pupil is nominally located to match the illumination pupil without oversizing, since it is not located at infinity. Therefore, there are no lumen losses traded for the highest overall contrast performance in this architecture.

#### 4.1.2 Mirror Gap

The device mirrors must have a small gap between them to allow them to rotate independently of each other in the on or off state without colliding with each other. The size of the gap is a function of the mirror size and the mirror-tilt angle. Tilt angle affects the gap because the mirrors also translate slightly as they rotate because they are supported by a post that displaces them from the hinge axis. The size of the gap determines the amount of structure under the mirrors that is exposed to illumination light, and strongly influences contrast ratio. For example, an increase in pixel gap of only 0.1 micron can produce as much as 20% contrast degradation in a telecentric architecture. Nontelecentric architectures are less sensitive to this effect due to the higher overall illumination angles.

### 4.1.3 Numerical Aperture

Numerical aperture can be used to improve contrast by certain ways of mismatching illumination- and projection-system numerical apertures. For example, if the projection-system numerical aperture is stopped down slower than the illumination system, this gives more spacing between the on-state pupil and flat- or off-state pupils, and can increase contrast. However, this comes at the expense of lumens.

Another option is to apply vignetting to the illumination system such that the corners of the device are illuminated at a lower numerical aperture (slower speed) than the center. This creates a smaller bundle for the illumination in the pupil, having the same effect as above. However, this can be done without significantly affecting brightness of the ANSI lumens measuring points, thus not decreasing ANSI lumen ratings of the system. Also, because the illumination rays are inverted/reverted by the mirror array, vignetting must occur on all the rays to those pixels. This requires two apertures in the illumination, on either side of a pupil, so rays are clipped, which defines inner and outer rays at the device. A separate application report (and patent) is available to describe this in detail.

The most effective method, however, does not change the numerical apertures overall, but selectively blocks certain areas of the pupil with a shaped aperture stop. For example, a D shaped stop could be placed in the illumination pupil in such a way as to map to the flat-state area that is closest to the on-state (projection) pupil. This will increase contrast with only slight effect on lumens, much like as in [Figure 11](#), even for nontelecentric systems.

### 4.1.4 Optical Design and Coating Quality

AR coatings for lenses or flat elements in the optical paths can affect contrast significantly, especially for telecentric architecture using a prism or a field lens. There are many paths for the reflected light from these surfaces to get through the projection lens and onto the screen, degrading contrast.

- Be aware of all first-order reflected light paths from all surfaces. For illumination paths, these reflections can enter the projection path, regardless of the state of the device since they occur prior to the device. For projection paths, minimize ghost images back to the device plane, which can be reflected to the screen off the device window or other flat areas. Also, be aware of any color-filter effects from AR coatings.
- Be aware of reflected light paths for the off- and flat-state light from the device, as well as flat state light from the device window. Ensure that there are no simple paths to the projection pupil. Many optical-analysis software packages are useful for this modeling.
- Elements that are between the projection lens stop and the device (including prisms and windows) have the greatest impact to contrast and should have the best affordable AR coatings and surface quality. Minimizing the number of lens elements in the projection lens between the projection lens stop and the device also is good design practice for maximum contrast. Glare stops or baffling in the lens barrel between the stop and the device also can prevent flat- and off-state light scattered or reflected into the lens from getting to the screen.
- Projection lens AR coatings generally will set the limit for the ANSI checkerboard contrast, because the lens contributes scattering and veiling glare when light is passing through it (unlike FO:FO contrast). Typically, if the FO:FO contrast is not much higher than the ANSI checkerboard contrast, the projection lens is performing well but there is some element in the illumination path that has a reflection getting to the screen. This typically indicates poor TIR prism coatings, or lack of ghost-reflection control on field-lens elements. If FO:FO and ANSI checkerboard both are low, the illumination has a serious problem and the projection lens cannot be evaluated until the noise floor is lowered by improving the illumination. If the FO:FO is where it should be, but ANSI checkerboard is much worse than the FO:FO, there likely are coating problems in the lens, or serious ghost-image issues. It also is important to baffle the lens barrel behind the stop (towards the device) as well as possible because it is likely to pick up flat- or even off-state light in a highly offset telecentric design as the rear of the lens grows with offset field. Nontelecentric designs avoid most of these problems, but can have more issues with control of the flat-state light reflecting off the device. It is very important to model device window reflections for a nontelecentric design if contrast and border image artifacts are important to the system design.

## 4.2 Lumens

The general relationship between lumens and contrast has been described in the contrast discussion in section 4.1. However, there is a possibility that products using certain devices may encounter a situation where more than one tilt angle may be available for the same device kit (device and compatible ASIC and other electronics). TI can recommend an optical platform that is compatible for multiple tilt angle devices, while achieving maximum lumen performance for each. Please contact TI for this application.

## 4.3 Optimizing Optical Costs

This section addresses considerations that can help prevent unnecessary costs due to overspecification of the optical design of the projector system.

### 4.3.1 UV Filtering

The device has specifications for maximum exposure levels of ultraviolet (UV) radiation for maximum lifetime reliability. Many types of glasses, glass coatings, and/or mirror coatings used in illumination optical elements can attenuate UV naturally. It is recommended that actual UV levels be measured at the device on early prototypes to determine how much, if any, additional filtering may be required. It may be helpful to design the projector optical engine tooling to provide a convenient place to mount a low-cost plate-glass UV-reduction coated filter if needed, and then use it only if needed. UV coatings are relatively expensive, so it is best to put them on small flat surfaces to maximize parts-per-coating-run costs, if needed. Also, lower cost filters are as low as 90% to 95% transmissive in the visible range, costing many lumens (and generating high local heat loads that must be heat-sunk effectively).

If these filters are located between the lamp and the color-wheel or integrator, they should be tilted at an angle to prevent localized heating of the lamp burner electrodes or wires by the back-reflected radiation. This tilt should also be accounted for in the specification of the filter for angle of incidence.

DMD's specifically designed for use with UV light are available for applications requiring UV illumination. Please contact TI for specifics for these applications.

### 4.3.2 Tolerancing

There are tolerance buildups that should be addressed according to each manufacturer's processes. For example, the device typically is drop-in mounted to the optical engine assembly with no adjustment, for maximum performance in the field (no adjustments that change during the lifetime of the product) and ease of assembly. The build-up of tolerances between the optical axis of the projection lens and the parallelism of the device plane, including device package tolerances, must be accounted for in the design of the projection lens for satisfactory MTF performance on the screen. The lens must have MTF margin to account for the apparent defocus of pixels caused by nonparallelism. These margins can be large in the design of the lens, allowing lower-cost/lower-precision mechanical processes in the engine parts. However, this tends to make the lenses larger due to more lens elements, and, therefore, higher in cost. This might be favorable, however, depending on the cost of the mechanical processes required to reduce the tolerance buildups. However, it may be more cost effective to have lower performance margins in the lens, but apply more precise processes to the mechanical tolerance buildups. Then, the lens will be smaller and less costly, and might meet a product size constraint that higher margin designs would not meet. The resultant MTF on the screen must be the same, regardless.

### 4.3.3 Throw-Ratio and Offset Optimization

In general, longer focal lengths for projection lenses result in smaller lenses, which lower costs. The lower magnifications of longer focal lengths typically reduce tolerance sensitivities, resulting in better and more consistent performance (tighter distributions), which can help with the tradeoffs mentioned in [Section 4.3.2](#) as well. Longer focal lengths mean longer throw ratios, and often there is a product requirement that sets some limit for this. If there is an option, it is generally better to go as long as possible for cost and performance reasons.

In the case of telecentric designs, it also is possible to consider offset as an independent variable. Projection offset is the amount by which the projected image must be raised above the optical axis of the projection lens. For example, 100% offset means that the bottom of the image is at the centerline of the projection lens, and 100% of the image falls above it. This is convenient for tabletop projectors, which

must project without interference from objects in front of the projector (including the table). It also produces a keystone-corrected image on a flat screen, unless the projector itself is tilted to raise the image further up. This offset amount determines the field radius required to be imaged by the projection lens at the device plane, which is the single most influential parameter driving the cost, size, and complexity of most lenses. Minimizing field size pays many dividends.

Therefore, for a given fixed image size (typically screen limited) and height from the floor, there is an opportunity to trade offset with tilting of the projector by increasing throw ratio, still resulting in acceptable keystone distortion. For example, if a 2-m wide image is desired to be 1.5 m from the floor at the bottom edge, a short-throw projector on a <1-m typical conference-room tabletop will have to be tilted more to raise the image the desired amount than a long-throw projector would, at the same offset. Therefore, the short-throw projector introduces more keystone distortion of the image than the long-throw projector because more angle is required to raise it any given distance. Therefore, for any acceptable keystone distortion specification and image size, the longer-throw projector can have less offset and can be tilted the same amount as the short-throw projector with more offset. This can reduce significantly the cost and size of the projection lens. An example comparison for various throw ratio and offset combinations is shown in Figure 12.

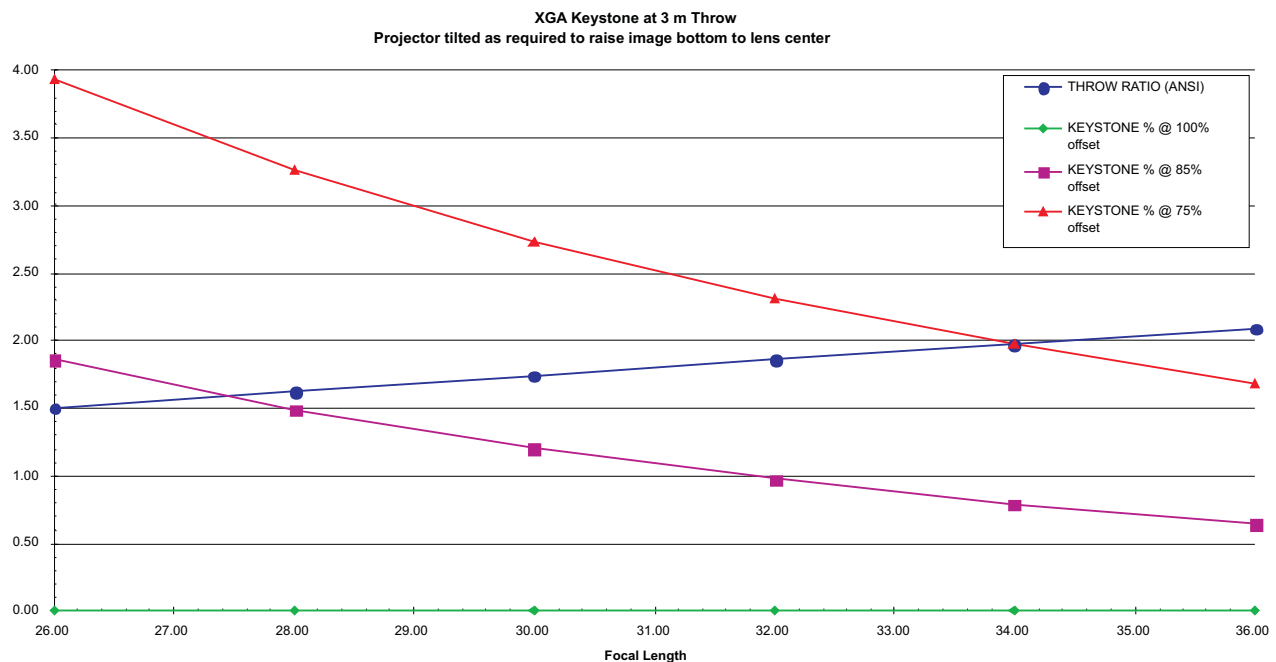

**Figure 12. Keystone Distortion for 0.9 XGA by Throw Ratio and Offset**

For example, a 2:1 throw-ratio lens for this 17-micron XGA device induces only 2% keystone distortion in the image (top will be 2% wider than the bottom) when the projector is tilted to bring the image bottom up to the center height of the lens, if field is reduced to 75% offset. Conversely, if 1% keystone distortion can be tolerated under these conditions, a 1.8:1 throw ratio lens could be used with only 85% offset field. Additionally, it can be seen that the keystone impact is nonlinear, indicating that longer-throw ratios increase keystone more slowly with increasing projector tilt than shorter-throw ratios. While the percentage reductions possible with these trades seem relatively small, they can have a significant impact on lenses because they affect area of the elements, which affects coating costs dramatically.

#### 4.3.4 Image Quality

It is important to understand the product application for the projection-lens requirements. For example, computer graphics use demands sharp pixel-edge definitions, requiring higher MTF specifications (see section 3.2) than video lenses. This is because meaningful data is mapped pixel-to-pixel from the source to the screen. By comparison, video-only applications may actually look better if the pixel-edge definition is smoothed or blended to be less noticeable. This means MTF requirements may be relaxed significantly, because it is rare that meaningful video image data is contained at the Nyquist resolution frequency. Likewise, misconvergence usually is less noticeable in video images (for CRT and three-panel displays), so lateral color effects also are likely to be less noticeable and may be relaxed. Cost trades can be made by considering expected applications in this manner.

## 5 Alternate Light Sources and Systems

### 5.1 LED Sources

One increasingly popular alternative to arc lamps for DLP systems is light emitting diodes (LEDs). There are several advantages to LED sources:

- Long life (if properly managed thermally) typically exceeding product lifetime. Thus, no lamp changes required.
- No gravity restraints on orientation of the LED, which allows the projector to be oriented in many different directions (for example, pointing up to a ceiling). There may be constraints related to the thermal solution, however.
- Fast response time makes them suitable for Field-Sequential-Color (FSC), the mode used for single-panel DMD systems. Capable of very high field rates for smooth motion video and no color breakup. Switching LEDs on and off eliminates the need for a color wheel, the only moving part in a conventional lamp based DLP system. Eliminates noise of color wheel and factory handling issues.
- Can be dynamically dimmed or boosted to greatly improve contrast or brightness or create multiple white point and color gamut modes.
- Environmentally friendly; no Mercury disposal. No rupture containment required.
- Highly saturated color gamut.
- Fast performance improvement cycle. Many companies, scientists, and engineers are working to improve LED efficiency for general lighting, signage, automotive, and industrial use. Projection industry can benefit from this fast learning cycle.
- No UV or IR filters needed.
- Non-polarized light from LED's is very efficient with DLP technology, which does not require polarization unlike LCD or LCoS technology. LEDs have negligible coherence for projector use, resulting in negligible speckle issues.
- LEDs are switched on and off according to the color sequence desired. They are not continually on like an arc lamp, so no energy is wasted creating light or heat in the colors not being displayed at a given instant.
- LEDs can be completely shut off when "displaying" a black screen. This results in theoretically infinite contrast ratio.

Of course, there are also some challenges:

- The primary issue with using LEDs is coupling their output efficiently into small etendue systems, like DLP or any microdisplay. Although the LEDs themselves are usually small, they emit into a very large angle, typically with a lambertian distribution. This increases the etendue of the LED and makes it very difficult to use many LEDs for a given system. Having a small LED and collecting a large angle from it is efficient, but will not necessarily produce the desired system luminance due to current density limitations of the small die. Alternately, one could collect a smaller angle and use a larger die, thus increasing the input power but reducing the collected output, which may yield higher projector luminance but at a lower efficiency. You can see from the LED collection curve in the figure below that "cutting off the tails" of the lambertian output may allow a smaller collection angle from a larger die without a big penalty in efficiency. There are a many trades to make when using LEDs.

## LED Lumens Collected into Solid Angle

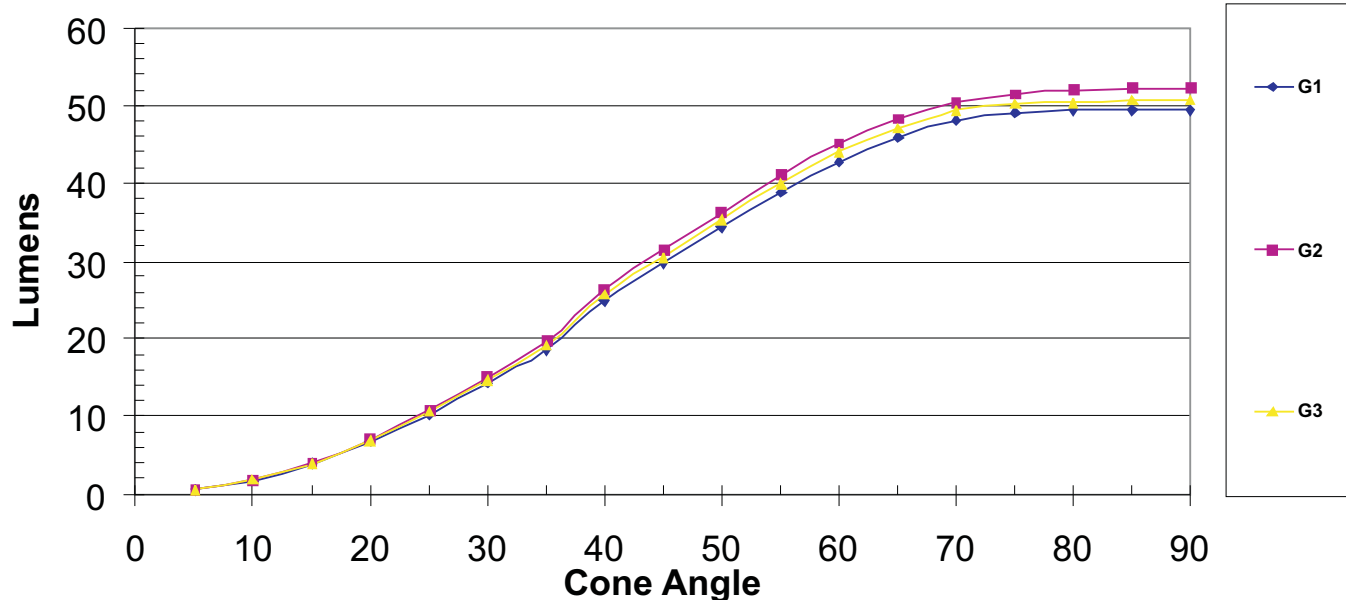

- LED behavior changes considerably with junction temperature. The characteristics are different depending on the type of LED construction used for the given color. For example, red colors typically behave quite differently from green or blue. This presents a challenge for achieving or maintaining a desired white point. Thermal characterization and active color output monitoring may be required.
- LEDs are typically grouped into performance bins that can have a wide range of performance specifications even within the same bin. The more bins that can be selected from to meet your product needs, the lower the cost of the die will be. But this can further complicate the ability to achieve the desired color balance and output.
- LED output may decay differently depending on the construction and material used for a given color. This produces differing decay rates between colors, causing white points to shift over time unless active color monitoring is used with some method to correct relative output.
- LED lifetime is strongly related to thermal control of the junction temperature.
- LED dominant wavelength will shift with temperature effects.

It is not difficult to characterize a given system using LEDs, but it is a very complicated trade study to optimize the design of one.

### 5.1.1 Projection Optical System Using LEDs

A typical layout for a projection system using LEDs is shown below in the figure below. The projector architectures used are the same as for lamp-based systems, with the exception of the light source and lack of color wheel. In this case telecentric TIR prism architecture is used, but it is easy to see that any telecentric, nontelecentric, or field lens architecture could be used since the projector is basically the same as a lamp system from the integrator to the screen.

There are many ways to arrange and combine the colors as well, such as cross-cube or plate dichroics, multi-color die in one or more packages with fan or wedge dichroic combiners, and some proprietary methods from other companies. Contact TI for details on these options. The method used typically depends on constraints for size, thermal management, and product packaging layout.

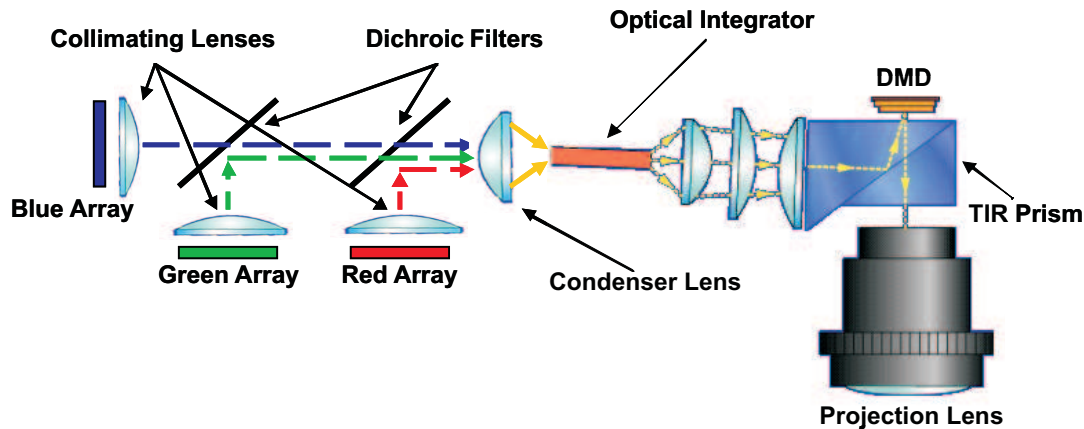

There are some advantages to using the rod or tunnel integrator, even for an LED projector:

- LEDs are typically square, and DMD's are typically rectangular. This causes mismatching of etendue and results in efficiency losses. This can be remedied by using a taper in one dimension of the integrator, with corresponding collection angles and/or anamorphic f/#'s, to "stretch" the etendue match up efficiently if constrained to square LED die.
- Color uniformity of LED systems is more difficult to achieve than spatial uniformity. Using a rod or tunnel integrator can improve color uniformity and provide consistent results.
- If the LEDs were directly imaged to the DMD without an integrator, then each color would have to be aligned very accurately to the DMD to achieve good color uniformity, spatial uniformity, and efficiency. This would be much like converging a 3-panel LCD system, which is a difficult process. By combining the three (or more) LEDs into a single integrator, only the integrator need be aligned to the DMD to do this. This is similar to the way the integrator is aligned in a lamp system, adding familiarity and simplicity to the process.

There are some occasions when a fly-eye lens array integrator would be a better choice:

- The fly-eye lens array eliminates the condenser lens, simplifies the relay lenses, and considerably shortens the path required for integration. It can result in a much shorter optical path, although it has some limitations in performance. For applications where minimal size is required, this is a better choice even at the expense of some efficiency.
- The LED output is collected and collimated in order to pass the dichroic filters without much spreading of the bandwidth due to variation in angle of incidence on the coating. The fly-eye lens array works best with well-collimated light, so it is a good fit if collimation is done well. An example layout of a lens array system is shown below.

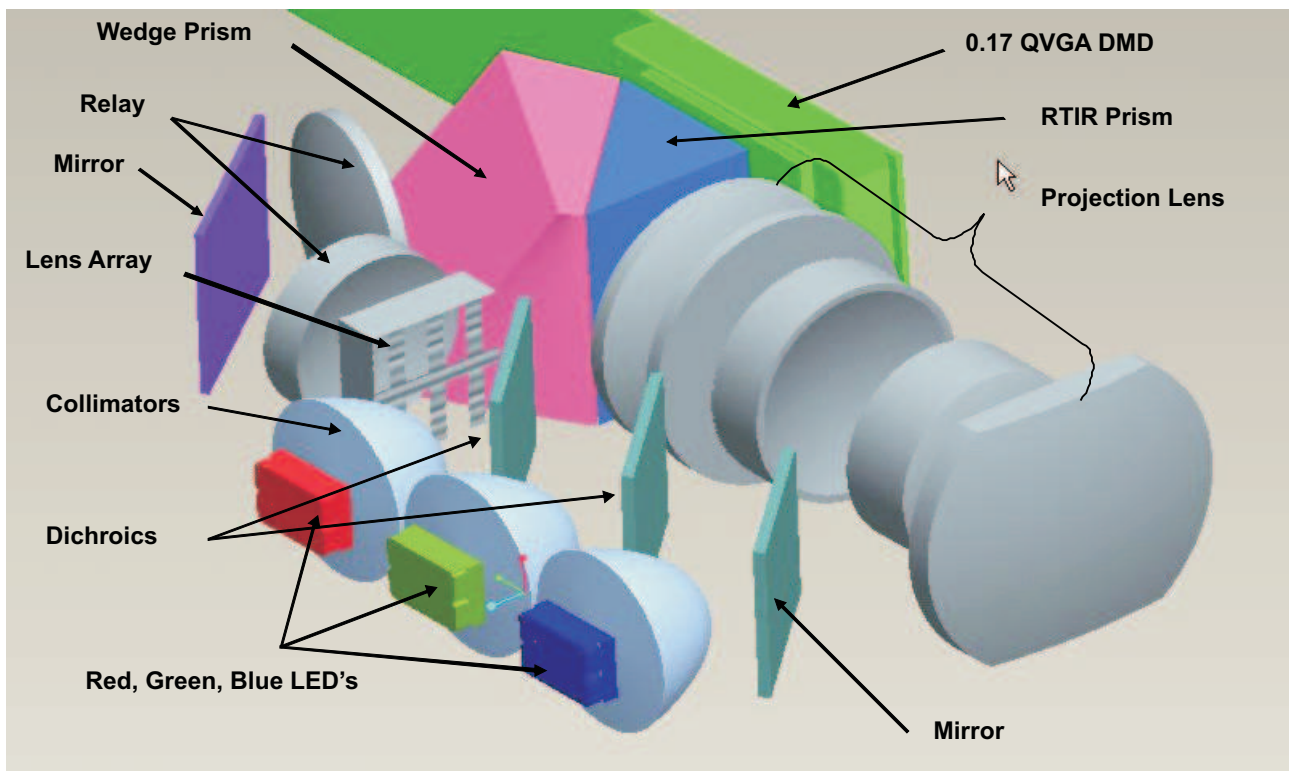

The potential disadvantages of the fly-eye lens array are:

- Cannot reshape the square LED die anamorphically, possibly reducing efficiency.
- The degree of collimation must be high for efficient lens array operation. This is because rays entering the first lens in each pair of lenslets in the array should also go through the corresponding on-axis lens in the pair. If the collimation is not good going in, some marginal rays will diverge too much after the first lens and skew into the adjacent off-axis lenslets surrounding the second lens instead. This produces “ghost” array images at the DMD that can be seen at the top, bottom, and each side, made up of these skew rays. These rays not only are lost light for efficiency, but may also illuminate structures in or around the DMD which create undesirable image artifacts on the screen.
- As DMD panel diagonal goes down, the size of the lens in the array gets smaller and the focal length gets shorter. This begins to strain existing manufacturing technologies, which become limited either by lens size or lens sag requirements.

## 5.2 Laser Sources

About the only thing laser sources have in common with LED sources is the ability to produce a very large color gamut. There are few similarities and many differences. Please refer to drawing 2509927 for more discussion about laser applications with DLP. Here are some of the potential advantages of laser sources:

- Since they are essentially very small point sources and emit into relatively low angular space, the etendue of the laser source is typically very small. This would theoretically allow a very small DMD to be coupled very efficiently to a laser, thus resulting in a large increase in die per wafer and a significant cost reduction for the DMD. In practice, several things conspire against this, which will be addressed later.
- The etendue of the source laser is much smaller than the DMD, therefore there are many more options for combining colors at the DMD that do not involve dichroic filter combination optics.
- Small, highly collimated sources result in the ability to use very high  $f/\#$  optics. This reduces the size of the optics significantly, and increases depth of focus so that focus adjustments are often eliminated, thus simplifying the mechanics as well. This should produce significant cost savings in both the optics and mechanics of a system, and significant reductions in size and volume of an optical engine.
- Lasers typically have much narrower spectral distribution than comparable LEDs, which can be important in some applications such as biomedical, chemical, communications, etc.



There are many potential challenges for laser applications:

- Serious regulatory and bureaucracy issues that present obstacles to getting products to market. Consumer acceptance of eye safety concerns, perceived or real.
- Laser light is typically polarized. While there is no efficiency penalty for unpolarized DLP technology with polarized light, neither is there a competitive efficiency advantage over polarized technologies such as LCD or LCoS as there is with unpolarized LEDs.
- The spatial coherence (due to small etendue) and temporal coherence (due to narrow wavelength spectrum) both contribute to serious speckle issues that are difficult to reduce to acceptable levels, and can require optical measures that usually expand etendue and/or bandwidth so much that the small-source etendue advantage of lasers is severely diminished.
- Energy density levels of laser sources for high brightness projection can require optical materials and workmanship quality that prohibit cost effectiveness.
- The manufacturing base for LEDs is very large compared to lasers because there are very large competitive markets for LEDs outside of projection applications. Lasers are typically created for specific applications. The relative economies of scale and pace of innovation are very different as a result. One possible exception may be the laser printer market as it may apply to laser sources for pico projection applications.
- The narrow laser wavelength spectrum can produce colors that may be “oversaturated” for many display applications, but can often be desaturated by adding small amounts of the other primary laser colors. This can improve luminance by reducing the gamut, but requires higher duty cycles for the lasers which can be a thermal or power consumption issue.

### **5.3 Non-Imaging or Non-Projection Applications**

There are many uses for the DMD outside of projection applications. The DMD is basically an array of digitally controlled switching mirrors that can be used to control or direct light into one of two directions in an addressable pattern at very high speeds. There are many applications for this that do not project an image. For example, switching or directing light in a fiber optic switching network, signal leveling in a fiber optic network, beam direction and patterning for a biomedical or machine vision or lithographic application, and countless others. Consider Figure 1 again, but imagine instead that a pulsed laser beam was injected into the DMD along what is shown as the On-State Energy path. That beam could then be directed into one of two directions  $\pm 24$  degrees away from the entry direction of the beam, and can be done in sync with the pulse repetition rate of a laser at a very high rate, and the output beam could be patterned into these two directions differently over the entire array at a very high speed. When you consider the DMD as a digital switch array rather than a microdisplay device, many new light processing applications can be imagined.

## IMPORTANT NOTICE

Texas Instruments Incorporated and its subsidiaries (TI) reserve the right to make corrections, modifications, enhancements, improvements, and other changes to its products and services at any time and to discontinue any product or service without notice. Customers should obtain the latest relevant information before placing orders and should verify that such information is current and complete. All products are sold subject to TI's terms and conditions of sale supplied at the time of order acknowledgment.

TI warrants performance of its hardware products to the specifications applicable at the time of sale in accordance with TI's standard warranty. Testing and other quality control techniques are used to the extent TI deems necessary to support this warranty. Except where mandated by government requirements, testing of all parameters of each product is not necessarily performed.

TI assumes no liability for applications assistance or customer product design. Customers are responsible for their products and applications using TI components. To minimize the risks associated with customer products and applications, customers should provide adequate design and operating safeguards.

TI does not warrant or represent that any license, either express or implied, is granted under any TI patent right, copyright, mask work right, or other TI intellectual property right relating to any combination, machine, or process in which TI products or services are used. Information published by TI regarding third-party products or services does not constitute a license from TI to use such products or services or a warranty or endorsement thereof. Use of such information may require a license from a third party under the patents or other intellectual property of the third party, or a license from TI under the patents or other intellectual property of TI.

Reproduction of TI information in TI data books or data sheets is permissible only if reproduction is without alteration and is accompanied by all associated warranties, conditions, limitations, and notices. Reproduction of this information with alteration is an unfair and deceptive business practice. TI is not responsible or liable for such altered documentation. Information of third parties may be subject to additional restrictions.

Resale of TI products or services with statements different from or beyond the parameters stated by TI for that product or service voids all express and any implied warranties for the associated TI product or service and is an unfair and deceptive business practice. TI is not responsible or liable for any such statements.

TI products are not authorized for use in safety-critical applications (such as life support) where a failure of the TI product would reasonably be expected to cause severe personal injury or death, unless officers of the parties have executed an agreement specifically governing such use. Buyers represent that they have all necessary expertise in the safety and regulatory ramifications of their applications, and acknowledge and agree that they are solely responsible for all legal, regulatory and safety-related requirements concerning their products and any use of TI products in such safety-critical applications, notwithstanding any applications-related information or support that may be provided by TI. Further, Buyers must fully indemnify TI and its representatives against any damages arising out of the use of TI products in such safety-critical applications.

TI products are neither designed nor intended for use in military/aerospace applications or environments unless the TI products are specifically designated by TI as military-grade or "enhanced plastic." Only products designated by TI as military-grade meet military specifications. Buyers acknowledge and agree that any such use of TI products which TI has not designated as military-grade is solely at the Buyer's risk, and that they are solely responsible for compliance with all legal and regulatory requirements in connection with such use.

TI products are neither designed nor intended for use in automotive applications or environments unless the specific TI products are designated by TI as compliant with ISO/TS 16949 requirements. Buyers acknowledge and agree that, if they use any non-designated products in automotive applications, TI will not be responsible for any failure to meet such requirements.

Following are URLs where you can obtain information on other Texas Instruments products and application solutions:

<b>Products</b>		<b>Applications</b>	
Amplifiers	<a href="http://amplifier.ti.com">amplifier.ti.com</a>	Audio	<a href="http://www.ti.com/audio">www.ti.com/audio</a>
Data Converters	<a href="http://dataconverter.ti.com">dataconverter.ti.com</a>	Automotive	<a href="http://www.ti.com/automotive">www.ti.com/automotive</a>
DLP® Products	<a href="http://www.dlp.com">www.dlp.com</a>	Communications and Telecom	<a href="http://www.ti.com/communications">www.ti.com/communications</a>
DSP	<a href="http://dsp.ti.com">dsp.ti.com</a>	Computers and Peripherals	<a href="http://www.ti.com/computers">www.ti.com/computers</a>
Clocks and Timers	<a href="http://www.ti.com/clocks">www.ti.com/clocks</a>	Consumer Electronics	<a href="http://www.ti.com/consumer-apps">www.ti.com/consumer-apps</a>
Interface	<a href="http://interface.ti.com">interface.ti.com</a>	Energy	<a href="http://www.ti.com/energy">www.ti.com/energy</a>
Logic	<a href="http://logic.ti.com">logic.ti.com</a>	Industrial	<a href="http://www.ti.com/industrial">www.ti.com/industrial</a>
Power Mgmt	<a href="http://power.ti.com">power.ti.com</a>	Medical	<a href="http://www.ti.com/medical">www.ti.com/medical</a>
Microcontrollers	<a href="http://microcontroller.ti.com">microcontroller.ti.com</a>	Security	<a href="http://www.ti.com/security">www.ti.com/security</a>
RFID	<a href="http://www.ti-rfid.com">www.ti-rfid.com</a>	Space, Avionics & Defense	<a href="http://www.ti.com/space-avionics-defense">www.ti.com/space-avionics-defense</a>
RF/IF and ZigBee® Solutions	<a href="http://www.ti.com/lprf">www.ti.com/lprf</a>	Video and Imaging	<a href="http://www.ti.com/video">www.ti.com/video</a>
		Wireless	<a href="http://www.ti.com/wireless-apps">www.ti.com/wireless-apps</a>

Mailing Address: Texas Instruments, Post Office Box 655303, Dallas, Texas 75265  
Copyright © 2010, Texas Instruments Incorporated